

2216 Nways Multiaccess Connector and  
Network Utility



# Service and Maintenance Manual



2216 Nways Multiaccess Connector and  
Network Utility

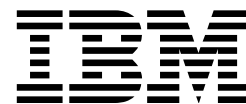

# Service and Maintenance Manual

**Note**

Before using this information and the product it supports, be sure to read the general information under Appendix G, "Notices" on page G-1, and safety information in Appendix H, "Safety Information" on page H-1.

**Sixth Edition (December 1998)**

This edition applies to the IBM 2216 Nways Multiaccess Connector Model 400 and Network Utility Model TX1 or TN1.

Order publications through your IBM representative or the IBM branch office serving your locality. Publications are not stocked at the address given below.

A form for readers' comments appears at the back of this publication. If the form has been removed, address your comments to:

Department CGF  
Design & Information Development  
IBM Corporation  
PO Box 12195  
RESEARCH TRIANGLE PARK NC 27709-9990  
USA

When you send information to IBM, you grant IBM a non-exclusive right to use or distribute the information in any way it believes appropriate without incurring any obligation to you.

© **Copyright International Business Machines Corporation 1997 1998. All rights reserved.**

Note to U.S. Government Users — Documentation related to restricted rights — Use, duplication or disclosure is subject to restrictions set forth in GSA ADP Schedule Contract with IBM Corp.

---

# Contents

<b>About This Manual</b> . . . . .	ix
Who Should Read This Manual . . . . .	ix
Library Overview . . . . .	ix
Ordering IBM Publications . . . . .	xii
Visit our Web Sites . . . . .	xiii
Information, Updates, and Corrections . . . . .	xiii
Product Support . . . . .	xiii
<b>Summary of Changes</b> . . . . .	xv
<b>Chapter 1. 2216 Model 400 Problem Determination</b> . . . . .	1-1
Model 400 Power Supply . . . . .	1-1
System Card LEDs . . . . .	1-1
LED Indicators . . . . .	1-2
Power Supply Status . . . . .	1-3
System Card Status . . . . .	1-3
Adapter Card Status . . . . .	1-3
Important Phone Numbers . . . . .	1-4
Troubleshooting . . . . .	1-4
Diagnosing Hardware Problems . . . . .	1-4
Diagnosing Operational Code and Configuration Problems . . . . .	1-4
MAP 0100: Basic Verification . . . . .	1-5
MAP 0110: Service Terminal Display Unreadable . . . . .	1-11
MAP 0120: Parallel Channel Problem Isolation . . . . .	1-14
MAP 0130: Verifying Repair Action for Parallel Channel . . . . .	1-15
<b>Chapter 2. Network Utility Problem Determination</b> . . . . .	2-1
Network Utility Power Supply . . . . .	2-1
System Card LEDs . . . . .	2-1
LED Indicators . . . . .	2-2
System Card Status . . . . .	2-2
Adapter Card Status . . . . .	2-2
Important Phone Numbers . . . . .	2-3
Troubleshooting . . . . .	2-3
Diagnosing Hardware Problems . . . . .	2-3
Diagnosing Operational Code and Configuration Problems . . . . .	2-4
MAP 0200: Basic Verification . . . . .	2-4
Where to Go for Additional Information . . . . .	2-7
<b>Chapter 3. 2216 Base Tools and Tests</b> . . . . .	3-1
Wrap Test and Terminator Plugs . . . . .	3-1
Service Kit—Feature Code 2505 (PN 85H7923) . . . . .	3-1
LIC 282, LIC 290, and LIC 291 External Wraps . . . . .	3-3
External Wrap Testing Parallel Channel Adapters . . . . .	3-5
Concepts . . . . .	3-5
Rules for Parallel Channel Adapter Testing . . . . .	3-5
Preparing the Wrap Blocks . . . . .	3-6
Running the Parallel Channel Adapter External Wrap Tests . . . . .	3-9
<b>Chapter 4. Removal and Replacement Procedures</b> . . . . .	4-1

Before You Start	4-1
Equipment You Need	4-1
Safety Precautions	4-1
Disconnecting the Power Cord	4-2
Reconnecting the Power Cord	4-2
Installing and Removing Channel Adapters	4-3
Parallel Channel Attachment	4-3
Using Interconnected V-Cables	4-8
Installing Channel Feature 2299	4-9
Parallel Channel Adapters Installation and Removal	4-10
ESCON Channel Adapter Cable Installation	4-14
Channel Interface Cable Replacement Procedure	4-16
Routing the Adapter Cables through the Cable Guides	4-17
Releasing the Device to Your Customer	4-17
<b>Chapter 5. Model 400 FRU Exchange</b>	5-1
Exchanging a Power Supply	5-2
Exchanging the System Card	5-3
Exchanging the Hard Drive on the System Card	5-6
Installing Operational Software on the New Hard Drive	5-8
Replacing the Memory on a System Card	5-9
Installing Memory Upgrades on a System Card	5-11
Exchanging the Fan Tray	5-13
Exchanging an Adapter	5-14
Exchanging the ISDN Daughter Card	5-18
Exchanging the Backplane	5-19
<b>Chapter 6. Model TX1 or TN1 FRU Exchange</b>	6-1
Exchanging the Power Assembly	6-2
Exchanging the System Card	6-5
Exchanging the Hard Drive on the System Card	6-7
Replacing the Memory on a System Card	6-9
Installing Memory Upgrades on a System Card	6-11
Exchanging a Fan	6-13
Exchanging an Adapter	6-15
Exchanging the Backplane	6-18
<b>Chapter 7. Accessing the Model 400 and Network Utility</b>	7-1
Access Methods	7-1
ASCII Terminal Setup and Usage	7-3
Attaching an ASCII Terminal	7-3
Serial Port and PCMCIA Modem Default Settings	7-4
ASCII Terminal Setup Attributes	7-4
Multiple Terminal Users	7-5
Telnet Setup and Usage	7-5
SLIP Addresses	7-6
PCMCIA LAN IP Addresses	7-6
Network Interface IP Addresses	7-6
Multiple Telnet Users	7-6
<b>Chapter 8. Using the Firmware</b>	8-1
Supervisory/Attended Mode	8-1
Unattended Mode	8-1
Starting Firmware	8-2

The Function Keys . . . . .	8-2
Obtaining Help . . . . .	8-2
Managing the Configuration . . . . .	8-3
Selecting the Boot Sequence . . . . .	8-5
Selecting a Device To Test . . . . .	8-7
Using the Utilities . . . . .	8-8
Setting the Power-On Password . . . . .	8-9
Setting the Supervisory Password . . . . .	8-10
Enabling Unattended Start Mode . . . . .	8-11
Disabling Unattended Start Mode . . . . .	8-12
Removing the Supervisory Password . . . . .	8-13
Updating System Firmware . . . . .	8-14
Displaying the Error Log . . . . .	8-16
Viewing or Setting Vital Product Data . . . . .	8-17
Setting Up Remote Initial Program Load . . . . .	8-19
Manipulating the Dead Man Timer . . . . .	8-20
Change Management . . . . .	8-20
<b>Chapter 9. Using Operational Diagnostics . . . . .</b>	<b>9-1</b>
Overview of Diagnostic Functions and Status Information . . . . .	9-1
Using the Command Line Interface Operational Diagnostics . . . . .	9-2
Testing the Adapters . . . . .	9-7
Powering On the IBM 2216 . . . . .	9-7
Running Diagnostics on the Adapter . . . . .	9-8
ESCON-only Tests . . . . .	9-10
Run the Light Test on the New Fiber Optic Cable . . . . .	9-10
ESCON Interactive Test Options . . . . .	9-13
ESCON Optical Power Measurement Test . . . . .	9-14
<b>Appendix A. Hardware Error Codes . . . . .</b>	<b>A-1</b>
<b>Appendix B. Parts Listings . . . . .</b>	<b>B-1</b>
Assembly 1: Final Assembly, 2216 - Model 400 . . . . .	B-2
Assembly 2: Final Assembly, 2216 - Model TX1 or TN1 . . . . .	B-4
2216 PCMCIA Modem and Cable Feature Codes for 2216 Model 400 or Network Utility Model TX1 or TN1 . . . . .	B-6
<b>Appendix C. Model 400 and Model TX1 or TN1 Hardware Characteristics</b>	<b>C-1</b>
Physical Specifications of the IBM 2216 Nways Multiaccess Connector Model 400 . . . . .	C-1
Weight . . . . .	C-1
Service Clearances . . . . .	C-1
Airflow . . . . .	C-1
Operating Environment . . . . .	C-2
Lightning Protection . . . . .	C-2
Electromagnetic Interference . . . . .	C-2
Power Supply . . . . .	C-2
Physical Specifications of the Network Utility . . . . .	C-2
Weight . . . . .	C-3
Service Clearances . . . . .	C-3
Airflow . . . . .	C-3
Operating Environment . . . . .	C-3
Lightning Protection . . . . .	C-3
Electromagnetic Interference . . . . .	C-3

Power Subsystem . . . . .	C-3
Power Cord Characteristics . . . . .	C-4
<b>Appendix D. Managing Operational Code and Configuration Files . . . . .</b>	<b>D-1</b>
Reconfiguring . . . . .	D-1
Managing the Operational and Configuration Software . . . . .	D-1
Software and Configuration Change Management . . . . .	D-1
How Software Files Are Managed . . . . .	D-1
How to View the Files . . . . .	D-2
How to Reset the IBM 2216 . . . . .	D-2
File Transfer Using TFTP . . . . .	D-3
File Transfer Using Xmodem . . . . .	D-5
Migrating to a New Code Level . . . . .	D-5
Using the Configuration Program to Manage the Configuration Files . . . . .	D-6
Change Management Functions . . . . .	D-8
Using the Copy Command . . . . .	D-9
File Transfer . . . . .	D-9
<b>Appendix E. Adapter Plugging Defaults . . . . .</b>	<b>E-1</b>
Model 400 Plugging Sequences . . . . .	E-1
Model 400 Slots and Adapters . . . . .	E-1
<b>Appendix F. Common Tasks for the 2216 Model 400 or Network Utility . . . . .</b>	<b>F-1</b>
LED States / Adapter Status . . . . .	F-1
Firmware Interface . . . . .	F-1
Command Line Interface . . . . .	F-1
Navigating Through the Command Line Interface . . . . .	F-1
Displaying List of Configured Interfaces . . . . .	F-2
Displaying the Operational State of the Interfaces . . . . .	F-3
Verifying Connectivity . . . . .	F-3
Viewing Vital Software Data . . . . .	F-3
Viewing Vital Hardware Data . . . . .	F-4
Adding an Adapter at Initial Configuration . . . . .	F-4
Adding an Adapter after Initial Configuration . . . . .	F-5
Running Quick Configuration . . . . .	F-6
Disabling an Adapter Port . . . . .	F-6
Enabling an Adapter Port . . . . .	F-6
Disabling an Adapter Slot . . . . .	F-7
Enabling an Adapter Slot . . . . .	F-7
Suspending Traffic on an Adapter Port . . . . .	F-7
Resuming Traffic on an Adapter Port . . . . .	F-7
Removing and Deleting an Adapter . . . . .	F-8
Up-to-Date Product Information . . . . .	F-8
Disabling Interfaces that Have WAN Reroute Enabled . . . . .	F-9
Enabling WAN Reroute after You Have Disabled it . . . . .	F-9
Remote File Download . . . . .	F-10
Spare Interfaces . . . . .	F-11
Configuring IP Addresses for a PCMCIA LAN Adapter . . . . .	F-11
<b>Appendix G. Notices . . . . .</b>	<b>G-1</b>
Notice to Users of Online Versions of This Book . . . . .	G-1
Electronic Emission Notices . . . . .	G-2
Industry Canada Class A Emission Compliance Statement . . . . .	G-2
Avis de conformité aux normes d'Industrie Canada . . . . .	G-2



Japanese Voluntary Control Council for Interference (VCCI) Statement . . .	G-2
CISPR22 Compliance Statement . . . . .	G-2
Taiwanese Class A Warning Statement . . . . .	G-3
EMC Directive 89/336/EEC Statement . . . . .	G-3
Telecommunication Notices . . . . .	G-4
Trademarks . . . . .	G-6
<b>Appendix H. Safety Information</b> . . . . .	<b>H-1</b>
Model 400 Caution Notices . . . . .	H-4
<b>Glossary</b> . . . . .	<b>X-1</b>
<b>Index</b> . . . . .	<b>X-11</b>



---

## About This Manual

Network Utility uses many of the same hardware components as the 2216 Model 400. Network Utility has a machine type of 2216 with two distinct models that are Model TX1 or TN1.

This manual provides the service representative with the information needed to:

- Analyze a problem or symptoms reported by the user
- Restore normal operation to the IBM 2216 Nways Multiaccess Connector Model 400 and Network Utility
- Exchange any of the FRUs in the 2216
- Run firmware and operational diagnostics

In this publication you will see the phrase *2216 base*. This phrase represents common hardware components, software components, and processes that are common to the 2216 Model 400 and the Network Utility.

Procedures that reference 2216 can be used for the Nways Multiaccess Connector Model 400 and the Network Utility. Procedures that are specific to the Model 400 or to the Network Utility are identified specifically.

---

## Who Should Read This Manual

This manual is for the use of the person providing level 1 remote support. Also, IBM service representatives will refer to this manual when servicing the 2216 Model 400 and the Network Utility on site. The person using this manual should be:

- Trained to service the 2216 Model 400 and the Network Utility
- Familiar with the configuration and operation of the 2216

---

## Library Overview

The Network Utility and the IBM 2216 Model 400 share many of the same publications. The following figure shows the publications in the library, arranged according to tasks.

Planning and Installation

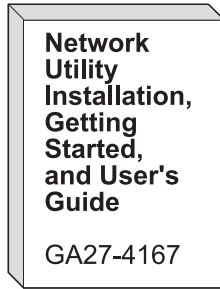
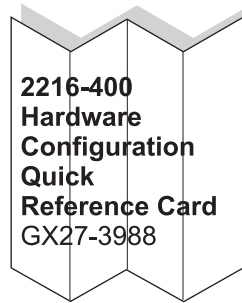
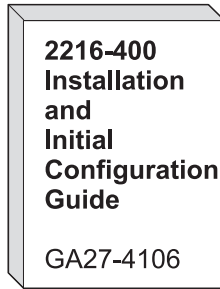

Configuration

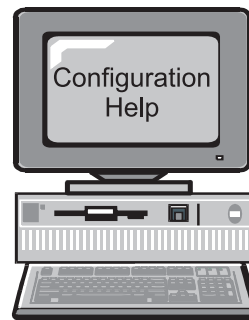
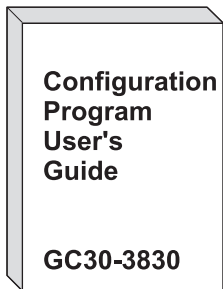

Diagnostics/Maintenance

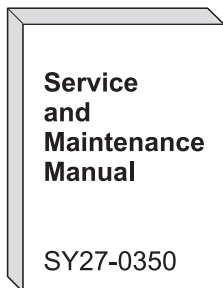

Operations and Network Administration

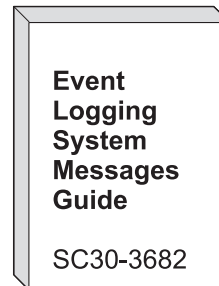
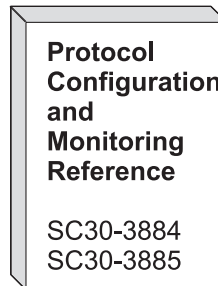
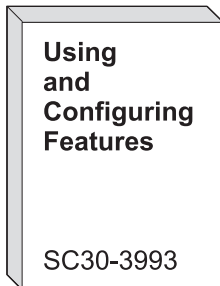

*Common Tasks and the Library for the IBM 2216 Model 400 and Network Utility*

*Table 0-1. Hardcopy Publications that Are Shipped with the product. These documents are shipped in hardcopy and are also contained on this product's Documentation CD-ROM, SK2T-0405.*

**Planning**

GA27-4105      *2216 Nways Multiaccess Connector and Network Utility Introduction and Planning Guide*

This book explains how to prepare for installation and select the hardware that you want to purchase. It includes specifications for the hardware and software for your network. It also provides information on the management of routing networks.

**Installation and Learning**

GA27-4167      Network Utility only:  
*Network Utility Installation, Getting Started, and User's Guide*

This book explains how to install a Network Utility and verify its installation. In addition it explains how to use the product and has sample configurations for the product.

GA27-4106      2216 Model 400 only:  
*2216 Nways Multiaccess Connector Model 400 Installation and Initial Configuration Guide*

This booklet explains how to install the 2216 Model 400 and verify its installation.

GX27-3988      2216 Model 400 only:  
*2216 Nways Multiaccess Connector Hardware Configuration Quick Reference*

This reference card is used for entering and saving hardware configuration information used to determine the correct state of an IBM 2216 Model 400.

**Diagnostics and Maintenance**

SY27-0350      *2216 Nways Multiaccess Connector and Network Utility Service and Maintenance Manual*

This book provides instructions for diagnosing problems with and repairing the Model 400 and the Network Utility.

**Safety**

SD21-0030      *Caution: Safety Information—Read This First*

This book provides translations of caution and danger notices applicable to the installation and maintenance of a device.

**Configuration**

GC30-3830      *Configuration Program User's Guide*

This book discusses how to use the Nways Multiprotocol Access Services Configuration Program.

*Table 0-2. Publications that Are Shipped as Softcopy on the CD-ROM. These publications are also separately orderable as hardcopy.*

### **Operations and Network Management**

The following books support the Nways Multiprotocol Access Services program.

SC30-3886	<i>Nways Multiprotocol Access Services Software User's Guide</i>
	This book explains how to: <ul style="list-style-type: none"><li>• Configure, monitor, and use the Nways Multiprotocol Access Services software and microcode.</li><li>• Use the Nways Multiprotocol Access Services command-line router user interface to configure and monitor the network interfaces and link-layer protocols shipped with the 2216 base.</li></ul>
SC30-3993	<i>Nways Multiprotocol Access Services Using and Configuring Features</i>
	This book describes Multiprotocol Access Services (MAS) features and explains the commands to use them. Features are any functions that enhance protocols or stand alone. Some examples are: MAC Filtering, which filters frames based on their MAC addresses, Bandwidth Reservation System, which enables you to reserve bandwidth for chosen types of traffic over a PPP or Frame Relay serial interface, or Network Address Translation, which enables you to represent one IP address with another when you are running IP.
SC30-3884	<i>Nways Multiprotocol Access Services Protocol Configuration and Monitoring Reference, Volume 1</i>
SC30-3885	<i>Nways Multiprotocol Access Services Protocol Configuration and Monitoring Reference, Volume 2</i>
	These books describe how to access and use the Nways Multiprotocol Access Services command-line user interface to configure and monitor the routing protocol software shipped with the product.
	They include information about each of the protocols that the device supports.
SC30-3682	<i>Nways Event Logging System Messages Guide</i>
	This book contains a listing of the error codes that can occur, along with descriptions and recommended actions to correct the errors.

---

## **Ordering IBM Publications**

In the U.S.A., you can order IBM publications by calling 1 800 879-2755. Within or outside the U.S.A., you can order IBM publications through the IBM Publications Direct Catalog on the World Wide Web at:

<http://www.elink.ibm.link.ibm.com/pb1/pb1>

IBM translates many publications into a variety of languages. The publications you need may be available in your language.

---

## Visit our Web Sites

These IBM web pages provide product information:

For the Network Utility: <http://www.networking.ibm.com/networkutility>

For the Model 400: <http://www.networking.ibm.com/216/216prod.html>

This IBM web page provides 2216 base and Network Utility books online:

<http://www.networking.ibm.com/did/2216bks.html>

## Information, Updates, and Corrections

This page provides information on engineering changes, clarifications, and fixes that were implemented after the books were printed:

<http://www.networking.ibm.com/216/216changes.html>

## Product Support

These pages provide downloads and additional support information:

For the Network Utility:

<http://www.networking.ibm.com/support/networkutility>

For the Model 400: <http://www.networking.ibm.com/support/2216>





---

## Summary of Changes

The hardware changes that are included in the 2216 base library and product since the previous edition of this product information consist of:

- Addition of a new system card for 2216 Model 400 and Network Utility
- Addition of optional 128-MB and 256-MB memory modules



---

## Chapter 1. 2216 Model 400 Problem Determination

**Note:** You will need to have the diagnostics run remotely by the operator at a station connected via the modem. Alternatively, the servicer can run the diagnostics on site through an ASCII terminal connected directly to the Model 400.

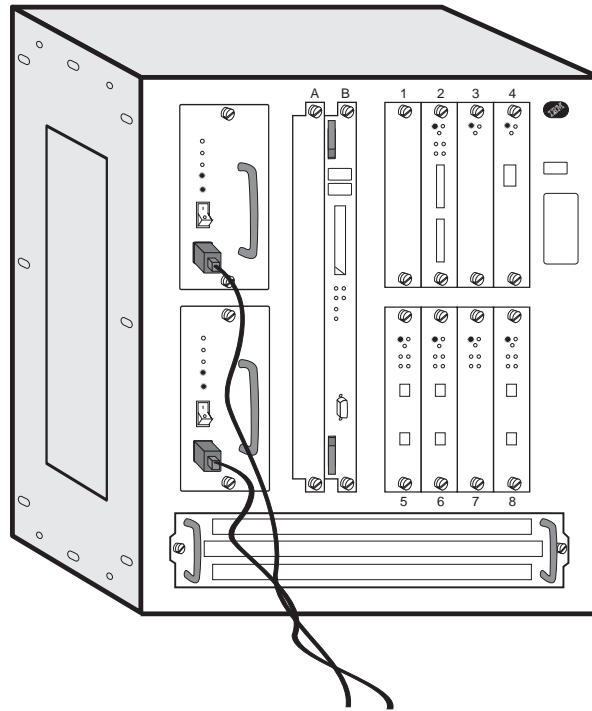

---

### Model 400 Power Supply

The power supply panel contains:

- The power switch, which is used to power ON or OFF the Model 400
- The Overcurrent Reset switch, which resets all current-limit circuits for the +12 V and -48 V outputs at the same time.

---

### System Card LEDs

After a power-on reset (POR), the green and yellow light-emitting diodes (LEDs) will remain on until successful completion of the power-on tests (which will be under 2 minutes). The green LED will begin blinking, which indicates that the code is being loaded into memory. The green LED will be switched on to indicate that the system code is operational.

**Note:** If the Model 400 is waiting for the power-on password, the green LED is off. If you do not have the console attached, you will not know that the system is waiting. Looking at the LEDs may lead you to believe that you have a hardware problem.

## LED Indicators

The Model 400 has a number of light-emitting diodes (LEDs) that indicate how the unit is functioning.

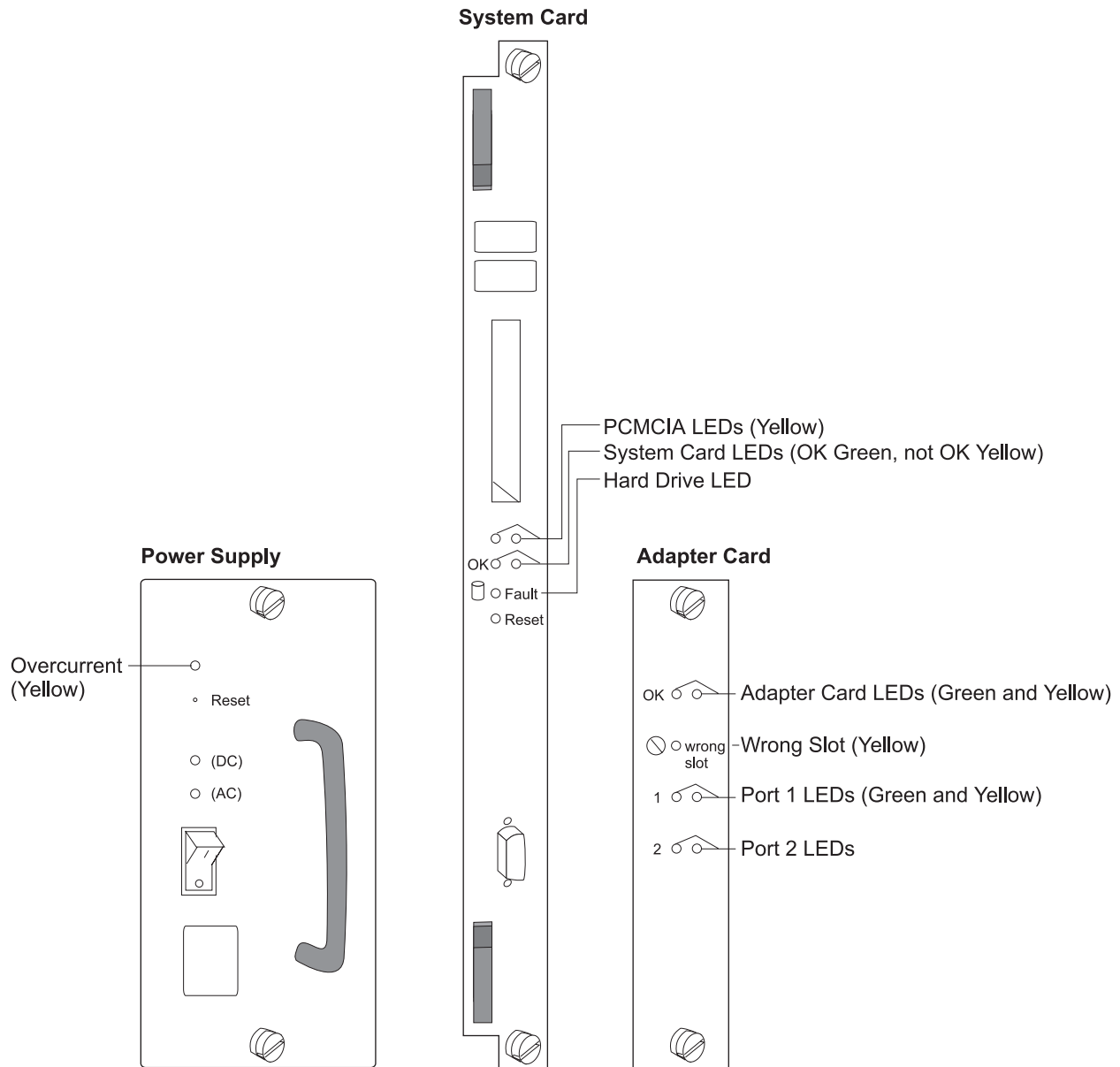

Figure 1-1. Power Supply, System Card, and Adapter Card LEDs

---

## Power Supply Status

LEDs	Meaning
Yellow (Overcurrent)	On - There is an overcurrent condition with the -48 V to one or more of the adapters (slots 1–8) or the +12 V to the fan tray.
Green DC	On - +5 V, +12 V, and -48 V are OK.
Green AC	On - AC source voltage is present and within tolerance.

---

## System Card Status

LEDs	Meaning
PCMCIA 1 or PCMCIA 2 (Yellow)	On - PCMCIA device has a fault, is not installed, or is not seated correctly. Off - Device passed self-tests
OK (Green)	On - Card hardware is operating normally. Blinking - Loading from hard file
(Yellow)	On - Card hardware has a fault.
Fault Hard Drive (Yellow)	On - Hard drive has failed.

---

## Adapter Card Status

LEDs	Meaning
OK (Green)	On - Adapter is operational.
(Yellow)	On - Adapter has a fault.
Wrong slot (Yellow)	On - Adapter is in the wrong slot.  The wrong slot LED is ON only when an adapter that is plugged into the Model 400 violates the plugging rules described in Appendix E, "Adapter Plugging Defaults" on page E-1.
Green port <sup>1</sup>	On - Port is operating normally (enabled and configured). Off - Port is not configured or is disabled. Blinking (for ESCON adapter only) - The optical power measurement test is running.
Yellow port <sup>1</sup>	On - One or more ports has a hardware fault. Blinking - One or more ports has a port I/O or network failure. Use the Maintenance Analysis Procedures (MAPs) to isolate. Off - No problem detected.

---

<sup>1</sup> The port LEDs of the multiport WAN adapters (FC 2282, FC 2290, and FC 2291) reflect the status of one or more of the ports.

---

### Important Phone Numbers

Contact Name	Telephone Number
System Administrator:	
Service Representative:	

---

### Troubleshooting

Both hardware and software (operational code and configuration) problems can affect the 2216 Model 400. Light-emitting diodes (LEDs), diagnostic programs, and error messages provide information needed for problem determination. This manual is chiefly concerned with diagnosing and correcting hardware problems. "Access Methods" on page 7-1 has information about accessing the 2216 base.

### Diagnosing Hardware Problems

Generally, errors that occur **before** the operational code is loaded are hardware-related. LEDs on the front of the 2216 Model 400 indicate how the hardware components are functioning.

Go to "LED Indicators" on page 1-2 for LED status and indicators for the 2216 Model 400. See Chapter 5, "Model 400 FRU Exchange" on page 5-1 for information on removal and replacement procedures for field-replaceable units (FRUs).

See Chapter 8, "Using the Firmware" on page 8-1 or Chapter 9, "Using Operational Diagnostics" on page 9-1 (depending on how you are connected to the 2216 Model 400) to run hardware diagnostics **before** the 2216 Model 400 has been configured.

### Diagnosing Operational Code and Configuration Problems

Generally, errors that occur **after** the operational code is loaded indicate problems with the operational code or configuration file.

Error codes and corrective action are described in the *Event Logging System Messages Guide*.

See Chapter 8, "Using the Firmware" on page 8-1 or Chapter 9, "Using Operational Diagnostics" on page 9-1 to run diagnostics **after** operational code and configuration files have been loaded.

## MAP 0100: Basic Verification

001

- On the Model 400:
  - Switch the power supply power ON.
  - Within 2 minutes, check the status of the LEDs on the front of the Model 400.
  - If the service terminal display is unreadable refer to “MAP 0110: Service Terminal Display Unreadable” on page 1-11.

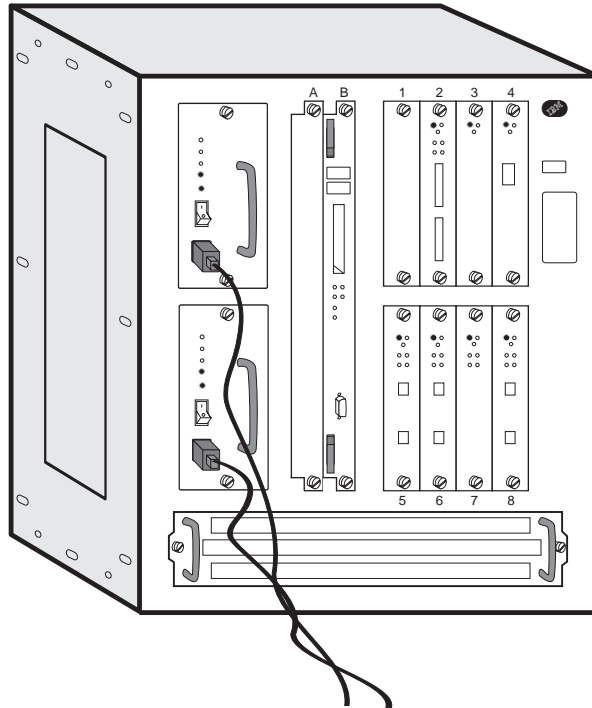

Table 1-1 on page 1-6 shows the desired status of the LEDs. The LEDs on the Model 400 should have the following status when operating normally.

## Problem Determination Model 400

Table 1-1. LED Status When the Model 400 is Operational

LED	Status
Power supply overcurrent yellow	OFF
Power supply <b>DC indicator</b>	ON
Power supply <b>AC indicator</b>	ON
System card PCMCIA (with device installed) Port 1 yellow	OFF
System card PCMCIA (with device installed) Port 2 yellow	OFF
System card green	ON
System card yellow	OFF
For all adapter cards, OK green LEDs	ON
For all adapter cards, not OK yellow LEDs	OFF
For all adapter cards, wrong slot yellow LED	OFF
For all adapter cards, all I/O port green LEDs	ON (If configured and enabled)
For all adapter cards, all I/O port yellow LEDs	OFF

### Are all LEDs OK?

Yes No

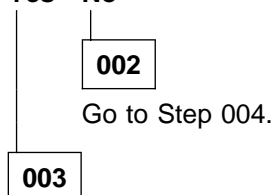

The Model 400 should be functioning.

**004**

– In Table 1-2, select the symptom that fits your situation.

Table 1-2. LED Status and Required Actions

LED Status	Action
<b>AC indicator</b> LED on a power supply is OFF.	Step 005 on page 1-7
<b>DC indicator</b> LED on a power supply is OFF and the AC indicator is ON.	Step 008 on page 1-7
<b>Overcurrent Indicator</b> LED on power supply is ON.	Step 011 on page 1-7
<b>Adapter yellow fault indicator LED</b> is ON (adapter is failing).	Step 018 on page 1-8
Adapter <b>Yellow</b> Wrong Slot LED is ON.	Step 021 on page 1-8
I/O port <b>Yellow</b> indicator is ON or BLINKING.	Step 024 on page 1-9
Yellow indicator on system card is ON.	Step 027 on page 1-9
PCMCIA yellow indicator on system card is ON.	Step 028 on page 1-9



**005**

– You are at this step because the AC indicator on a power supply is OFF.  
Perform the following tests:

1. On the suspected power supply, check that:
  - The power cable is correctly connected to the ac power outlet and to the front of the power supply.
  - The power supply is correctly seated in the unit.
2. With a multimeter, check that there is power at the power outlet.
3. With the power cable connected to the power outlet, use a multimeter to verify that the power cable is good.

If you detect no problems with any of the above, replace the power supply. See “Exchanging a Power Supply” on page 5-2.

**Is the AC indicator LED now ON?**

Yes No

**006**

Call your support center for assistance.

**007**

– Restart the verification procedure. Go to Step 001 on page 1-5.

---

**008**

**The DC indicator on a power supply is OFF. Replace the power supply. (See “Exchanging a Power Supply” on page 5-2.) Is the problem corrected?**

Yes No

**009**

Contact your support center for assistance.

**010**

Restart the verification procedure. Go to Step 001 on page 1-5.

---

**011**

**The Overcurrent LED on a power supply is ON. Are all adapter yellow fault LEDs OFF?**

Yes No

**012**

**Remove the adapter with a yellow fault LED ON, and then press Reset on the power supply. Is the Overcurrent LED now OFF?**

Yes No

**013**

(Step **013** continues)

**013** (continued)

Replace the power supply. Restart the verification procedure. Go to Step 001 on page 1-5.

**014**

Replace the adapter. (See “Exchanging an Adapter” on page 5-14.) Restart the verification procedure. Go to Step 001 on page 1-5.

---

**015**

**The problem may be with the fan tray. Remove it (see “Exchanging the Fan Tray” on page 5-13) and press Reset. Does this correct the problem?**

**Yes No**

**016**

Reinstall the fan tray. Contact your support center.

**017**

Replace the fan tray and restart the verification procedure. Go to Step 001 on page 1-5.

---

**018**

**A yellow fault indicator LED on an adapter is ON. Replace the adapter. (See “Exchanging an Adapter” on page 5-14.) Does this correct the problem?**

**Yes No**

**019**

Contact your support center.

**020**

Restart the verification procedure. Go to Step 001 on page 1-5.

---

**021**

– The **yellow** Wrong Slot LED indicator on an adapter is ON. The Wrong Slot LED indicates that one of the following restrictions is not being observed:

1. If adapter LIC 280 or LIC 281 is in slot 3, then slot 4 must be empty.
2. If adapter LIC 280 or LIC 281 is in slot 4, then slot 3 must be empty.
3. If adapter LIC 280 or LIC 281 is in slot 7, then slot 8 must be empty.
4. If adapter LIC 280 or LIC 281 is in slot 8, then slot 7 must be empty.

Relocate the adapter or adapters in slots 3, 4, 7, or 8 accordingly.

**After relocating the adapters are all Wrong slot LEDs off?**

**Yes No**

**022**

(Step **022** continues)

**022** (continued)  
 Call your support center for assistance.

**023**

– Restart the verification procedure. Go to Step 001 on page 1-5.

---

**024**

**A yellow LED indicator for an I/O port is ON or BLINKING. Is the yellow LED indicator BLINKING?**

Yes No

**025**

– **I/O port LED ON.** The adapter is defective. Replace it. (See “Exchanging an Adapter” on page 5-14.) Restart the verification procedure. Go to Step 001 on page 1-5.

**026**

– **I/O port LED BLINKING**

There is a problem with the adapter, the cable, the network, or the adapter software configuration is wrong.

Run an external wrap test on the I/O port. You must install an external wrap block (plug) prior to the test. (See “Wrap Test and Terminator Plugs” on page 3-1 for the correct wrap plug.) See “Using the Command Line Interface Operational Diagnostics” on page 9-2 to run the diagnostics.

1. If the wrap test is successful, suspect the cable, the network, or that the adapter software configuration is wrong. Correct any problem that you find. Restart the verification procedure. Go to Step 001 on page 1-5.
  2. If you suspect a problem with the ESCON adapter, run the light test (see page 9-10).
- 

**027**

**A yellow LED on the system card is ON. Is the Hard Drive LED ON?**

Yes No

**028**

**Is a PCMCIA Slot 1 or 2 LED ON?**

Yes No

**029**

If system card fault yellow LED is on, the system card is defective. Replace it. See “Exchanging the System Card” on page 5-3. Restart the verification procedure. Go to Step 001 on page 1-5.

**030**

- The LED will be ON if there is no device plugged into the slot. (Step **030** continues)

## Problem Determination Model 400

### 030 (continued)

- If a PCMCIA device is plugged into the slot and the LED is ON, reseal the PCMCIA device and press the **Reset** on the System Card.
  - If the LED is still ON replace the PCMCIA device.
- 

### 031

There is a hard drive failure. Replace the hard drive. See “Exchanging the Hard Drive on the System Card” on page 5-6. Restart the verification procedure. For Model 400, go to Step 001 on page 1-5.

---

## MAP 0110: Service Terminal Display Unreadable

Symptom Explanation	Conditions That Could Cause This Symptom
<p>While you are diagnosing a problem, a terminal attached to the service port of the IBM 2216 displays random characters instead of readable text.</p>	<ul style="list-style-type: none"> <li>• Incorrect configuration setting of the terminal or IBM 2216 service port.</li> <li>• Incorrect terminal/device (ac) grounds.</li> <li>• Defective, incorrectly shielded, or incorrectly grounded EIA 232 cable between the terminal and the IBM 2216.</li> <li>• Defective terminal or terminal emulator.</li> <li>• High ambient electromagnetic interference (EMI) levels.</li> <li>• Power line disturbances.</li> <li>• Defective IBM 2216 system board.</li> </ul>

**001**

(Active state is indicated by the green system LED on and the yellow system LED off.)

**Does the IBM 2216 go to the active state within 2 minutes of resetting or powering on?**

**Yes No**

**002**

If you are using a Model 400, go to Step 001 on page 1-5. If you are using a model TX1 or TN1, go to Step 001 on page 2-4.

**003**

Go to Step 004.

---

**004**

– Press the service terminal break key sequence and press **Enter**.

You should try this a number of times before proceeding.

A typical terminal break key sequence is **Alt-b**.

– Press **Ctrl-p** at the service terminal.

**Is the terminal functioning correctly?**

**Yes No**

**005**

– Go to Step 007 on page 1-12.

**006**

(Step **006** continues)

## Problem Determination Model 400

**006** (continued)

– Go to Step 001 on page 1-5.

---

**007**

**Is the terminal or the IBM 2216 grounded correctly?**

**Yes No**

**008**

Ground the device correctly. If you are using a Model 400, go to Step 001 on page 1-5. If you are using a Model TX1 or TN1, go to Step 001 on page 2-4.

**009**

**Is the EIA 232 cable between the terminal and the IBM 2216 grounded correctly and shielded?**

**Yes No**

**010**

Ground or shield the cable correctly or replace the cable. If you are using a Model 400, go to Step 001 on page 1-5. If you are using a Model TX1 or TN1, go to Step 001 on page 2-4.

**011**

**Is the terminal or the terminal emulator functioning correctly?**

**Yes No**

**012**

Replace the terminal or the terminal emulator. If you are using a Model 400, go to Step 001 on page 1-5. If you are using a Model TX1 or TN1, go to Step 001 on page 2-4.

**013**

**Is the IBM 2216 in an area with high ambient electromagnetic interference?**

**Yes No**

**014**

**Are there power line disturbances?**

**Yes No**

**015**

The IBM 2216 system board is defective. Replace the system board. If you are using a Model 400, go to Step 001 on page 1-5. If you are using a Model TX1 or TN1, go to Step 001 on page 2-4.

**016**

Install an uninterruptible power supply to minimize the effects of the power fluctuations. If you are using a Model 400, go to Step 001 on page 1-5. If you are using a Model TX1 or TN1, go to Step 001 on page 2-4.

---

**017**

Move the IBM 2216 to a more isolated area. If you are using a Model 400, go to Step 001 on page 1-5. If you are using a Model TX1 or TN1, go to Step 001 on page 2-4.

---

## MAP 0120: Parallel Channel Problem Isolation

001

–

**Note:** This procedure requires a channel-trained IBM service representative or customer's channel-trained person.

- Make sure that all cables are marked so that they can be reconnected to the appropriate adapters.

<i>Table 1-3. Initial Symptom</i>	
Symptom Explanation	Conditions That could Cause the Symptom
<p>There is a communication problem on a parallel channel. A symptom indicates a channel communication problem between the host and the IBM 2216.</p>	<ol style="list-style-type: none"> <li>1. Select/Bypass Switch set to <b>B</b> (bypass) position (see Figure 4-9 on page 4-12)</li> <li>2. Terminators have not been installed at the end of the channel</li> <li>3. Bus and tag terminators have been interchanged (when you are using a cabling scheme that uses the Channel Interface-out)</li> <li>4. Total bus or tag cable length is greater than the maximum length of 113 m (370 feet). To calculate total cable length, take: <math>400 - (\text{number-of-Parallel Channel Adapters} * 30 \text{ ft})</math>.</li> <li>5. Total number of Parallel Channel Adapters on this bus and tag cable exceeds the maximum of six.</li> <li>6. The Parallel Channel Adapter is cabled to the wrong channel.</li> <li>7. The logical connection is not defined correctly (in the IOCDS)</li> <li>8. Bent pins on the bus or tag cables or terminators (which is often caused by attempting to seat the connector without using the attaching screw on the cable)</li> <li>9. Defective:             <ol style="list-style-type: none"> <li>a. Parallel Channel Adapter</li> <li>b. V-cable</li> <li>c. Channel Interface Cables</li> </ol> <p style="margin-left: 40px;">Run diagnostic tests (see "Testing the Adapters" on page 9-7).</p> </li> <li>10. Host problem</li> </ol>



## MAP 0130: Verifying Repair Action for Parallel Channel

**001**

- Make sure that all cables are marked so that they can be reconnected to the appropriate adapters.
- Follow the sequence in “Testing the Adapters” on page 9-7 to test all the components that are installed in the IBM 2216

–

**Note:** This procedure requires a channel-trained IBM service representative or customer’s channel-trained person.

**Did all of the IBM 2216 diagnostics run without errors?**

Yes No

**002**

- Replace the failing hardware. Perform the action indicated by the diagnostic test.

**003**

**Did you replace a Parallel Channel Adapter?**

Yes No

**004**

- Connect all communication cables to their respective networks.
- Return the IBM 2216 to the customer.

**005**

- Run the Parallel Channel Adapter test with wrap blocks. See “Running the Parallel Channel Adapter External Wrap Tests” on page 3-9.

**Did the Parallel Channel Adapter tests run without error?**

Yes No

**006**

- Go to “MAP 0120: Parallel Channel Problem Isolation” on page 1-14.

**007**

- Re-connect all associated cables.
  - Verify that the Select/Bypass Switch on the V-cable is in the **S** position.
  - Return the IBM 2216 to the customer.
-

## Problem Determination Model 400

---

## Chapter 2. Network Utility Problem Determination

**Note:** You will need to have the diagnostics run remotely by the operator at a station connected via the modem. Alternatively, the servicer can run the diagnostics on site through an ASCII terminal connected directly to the Network Utility.

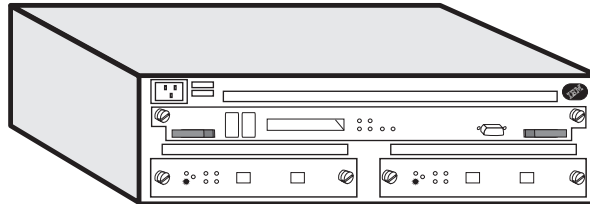

---

### Network Utility Power Supply

There is one fixed power subsystem on the Network Utility with a single power cord and no power switch.

---

### System Card LEDs

After power-on-reset (POR), the green and yellow LEDs will remain on until successful completion of the power-on tests (which will be under 2 minutes). The green LED will begin blinking, which indicates that the code is being loaded into memory. The green LED will be switched on to indicate that the system code is operational.

**Note:** If the Network Utility is waiting for the power-on password, the green LED is off. If you do not have the console attached, you will not know that the system is waiting. Looking at the LEDs may lead you to believe that you have a hardware problem.

## LED Indicators

The Network Utility has a number of light-emitting diodes (LEDs) that indicate how the unit is functioning.

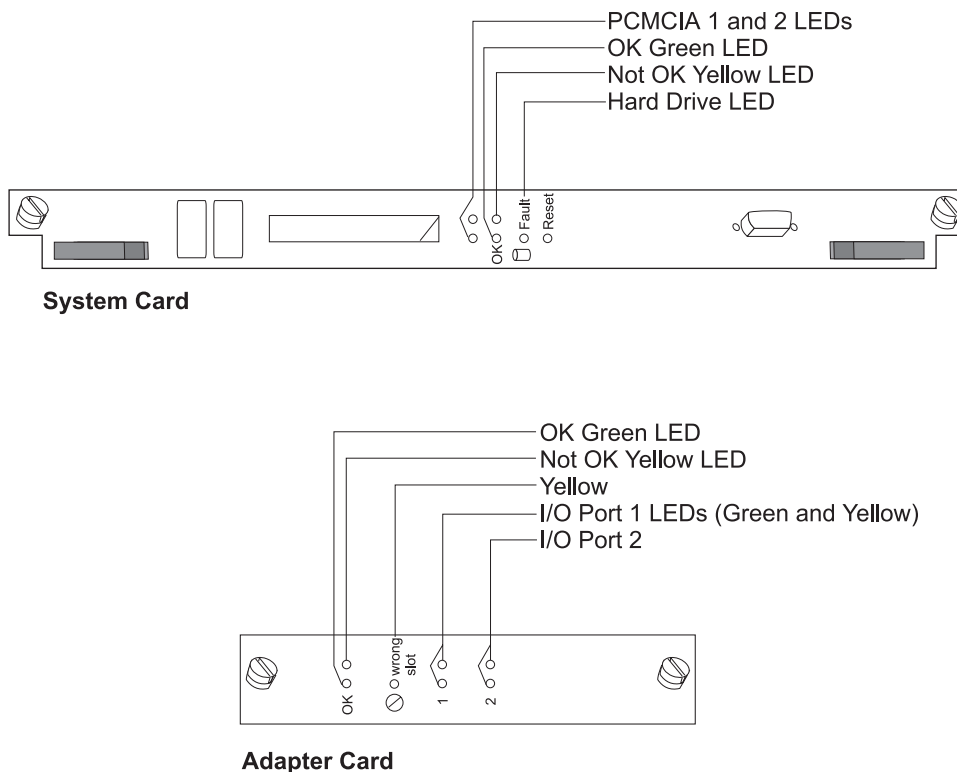

Figure 2-1. System Card and Adapter Card LEDs

## System Card Status

LEDs	Meaning
PCMCIA 1 or PCMCIA 2 (Yellow)	On - PCMCIA device has a fault, is not installed, or is not seated correctly. Off - Device passed self-tests
OK (Green)	On - Card hardware is operating normally. Blinking - Loading from hard file
(Yellow)	On - Card hardware has a fault.
Fault Hard Drive (Yellow)	On - Hard drive has failed.

## Adapter Card Status

LEDs	Meaning
OK (Green)	On - Adapter is operational.
(Yellow)	On - Adapter has a fault.
Wrong Slot (Yellow)	On - Contact your service representative.
Green port <sup>1</sup>	On - Port is operating normally (enabled and configured). Off - Port is not configured or is disabled. Blinking (for ESCON adapter only) - The optical power measurement test is running.
Yellow port <sup>1</sup>	On - One or more ports has a hardware fault. Blinking - One or more ports has a port I/O or network failure. Use the Maintenance Analysis Procedures (MAPs) to isolate. Off - No problem detected.

## Important Phone Numbers

Contact Name	Telephone Number
System Administrator:	
Service Representative:	

## Troubleshooting

Both hardware and software (operational code and configuration) problems can affect the Network Utility. Light-emitting diodes (LEDs), diagnostic programs, and error messages provide information needed for problem determination. This manual is chiefly concerned with diagnosing and correcting hardware problems. “Access Methods” on page 7-1 has information about accessing the Network Utility.

## Diagnosing Hardware Problems

Generally, errors that occur **before** the operational code is loaded are hardware-related. LEDs on the front of the Network Utility indicate how the hardware components are functioning.

Go to “LED Indicators” on page 2-2 for LED status and indicators for the Network Utility. See Chapter 6, “Model TX1 or TN1 FRU Exchange” on page 6-1 for information on removal and replacement procedures for field-replaceable units (FRUs).

See Chapter 8, “Using the Firmware” on page 8-1 or Chapter 9, “Using Operational Diagnostics” on page 9-1 (depending on how you are connected to the Network Utility) to run hardware diagnostics **before** the Network Utility has been configured.

<sup>1</sup> The port LEDs of the multiport WAN adapters (FC 2282, FC 2290, and FC 2291) reflect the status of one or more of the ports.

### Diagnosing Operational Code and Configuration Problems

Generally, errors that occur **after** the operational code is loaded indicate problems with the operational code or configuration file.

Error codes and corrective action are described in the *Event Logging System Messages Guide*.

See Chapter 8, “Using the Firmware” on page 8-1 or Chapter 9, “Using Operational Diagnostics” on page 9-1 to run diagnostics **after** operational code and configuration files have been loaded.

### MAP 0200: Basic Verification

001

- On the Network Utility:
  - Insert the power cord into an active power receptacle.
  - Within 2 minutes, check the status of the LEDs on the front of the Network Utility.
  - If the service terminal display is unreadable refer to “MAP 0110: Service Terminal Display Unreadable” on page 1-11.

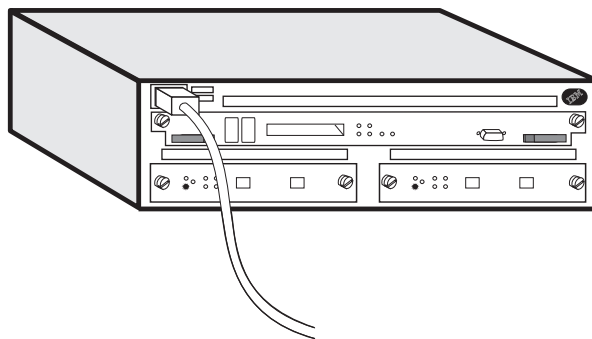

Table 2-1 on page 2-5 shows the desired status of the LEDs. The LEDs on the Network Utility should have the following status when operating normally.

Table 2-1. Machine LEDs When Operational

LED	Status
System card PCMCIA (with device installed) Port 1 yellow	OFF
System card PCMCIA (with device installed) Port 2 yellow	OFF
System card green	ON
System card yellow	OFF
All adapter green LEDs	ON
All adapter yellow LEDs	OFF
Wrong slot LED	OFF
All I/O port green LEDs	ON
All I/O port yellow LEDs	OFF

**Are all LEDs OK?**

Yes No

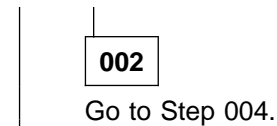

**003**

The Model TX1 or TN1 should be functioning.

**004**

– In Table 2-2, select the symptom that fits your situation.

Table 2-2. LED and symptoms

LED Status	Action
ALL LEDs are OFF.	Step 005
Adapter yellow fault indicator LED is ON (adapter is failing).	Step 008 on page 2-6
I/O port Yellow indicator is ON or BLINKING.	Step 011 on page 2-6
Yellow indicator on system card is ON	Step 014 on page 2-7
PCMCIA yellow indicator on system card is ON	Step 015 on page 2-7

**005**

– You are at this step because **all** LEDs are OFF. Perform the following tests:

1. Check that:

- The power cable is correctly connected to the ac power outlet and to the power supply.

(Step **005** continues)

## Problem Determination Network Utility

**005** (continued)

- The power supply is correctly seated in the unit.
2. With a multimeter, check that there is power at the power outlet.
  3. With the power cable connected to the power outlet, use a multimeter to verify that the power cable is good.

If you detect no problems with any of the above, replace the power supply. See “Exchanging the Power Assembly” on page 6-2.

**Are there any indicator LEDs now ON?**

Yes No

**006**

Call your support center for assistance.

**007**

– Restart the verification procedure. Go to Step 001 on page 2-4.

---

**008**

**A yellow fault indicator LED on an adapter is ON. Replace the adapter. (See “Exchanging an Adapter” on page 5-14.) Does this correct the problem?**

Yes No

**009**

Contact your support center.

**010**

Restart the verification procedure. Go to Step 001 on page 2-4.

---

**011**

**A yellow LED indicator for an I/O port is ON or BLINKING. Is the yellow LED indicator BLINKING?**

Yes No

**012**

- **I/O port LED ON** - The adapter is defective. Replace it. (See “Exchanging an Adapter” on page 5-14.) Restart the verification procedure. Go to Step 001 on page 2-4.

**013**

– **I/O port LED BLINKING**

There is a problem with the adapter, the cable, the network, or the adapter software configuration is wrong.

Run an external wrap test on the I/O port. You must install an external wrap block (plug) prior to the test. (See “Wrap Test and Terminator Plugs” on page 3-1 for the correct wrap plug.) See “Using the Command Line Interface Operational Diagnostics” on page 9-2 to run the diagnostics.

(Step **013** continues)



**013** (continued)

1. If the wrap test is successful, suspect the cable, the network, or that the adapter software configuration is wrong. Correct any problem that you find. Restart the verification procedure. Go to Step 001 on page 2-4.
2. If you suspect a problem with the ESCON adapter, run the light test (see page 9-10).

**014**

**A yellow LED on the system card is ON. Is the Hard Drive LED ON?**

Yes No

**015**

**Is a PCMCIA Slot 1 or 2 LED ON?**

Yes No

**016**

If system card fault yellow LED is on, the system card is defective. Replace it. See “Exchanging the System Card” on page 6-5. Restart the verification procedure. Go to Step 001 on page 2-4.

**017**

- The LED will be ON if there is no device plugged into the slot
- If a PCMCIA device is plugged into the slot and the LED is ON, reseal the PCMCIA device and press the **Reset** on the System Card.
- If the LED is still ON replace the PCMCIA device.

**018**

There is a hard drive failure. Replace the hard drive. See “Exchanging the Hard Drive on the System Card” on page 6-7. Restart the verification procedure. Go to Step 001 on page 2-4.

## Where to Go for Additional Information

- See “MAP 0110: Service Terminal Display Unreadable” on page 1-11 for detailed information on service terminal display unreadable for the Network Utility.
- See “MAP 0120: Parallel Channel Problem Isolation” on page 1-14 for detailed information on parallel channel problem isolation for the Network Utility.
- See “MAP 0130: Verifying Repair Action for Parallel Channel” on page 1-15 for detailed information on verifying repair action for the parallel channel for the Network Utility.
- See “Wrap Test and Terminator Plugs” on page 3-1 for detailed information on wrap test and terminator plugs for the Network Utility.

## Problem Determination Network Utility

---

## Chapter 3. 2216 Base Tools and Tests

---

### Wrap Test and Terminator Plugs

Wrap test terminator plugs for the Parallel Channel Adapter (LIC 299) are not part of the service kit. The part numbers are shown in Table 3-1.

*Table 3-1. LIC 299 Wrap Test Plugs and Terminator Plugs*

<b>Plug Name</b>	<b>Part Number</b>	<b>Usage</b>
V-cable terminator (included with LIC 299)	25L4747	IBM 2216
V-cable wrap (included with LIC 299)	71F1184	IBM 2216
Tag wrap	8575338	Standard
Bus wrap	8575337	Standard
Tag terminator	2282676	Standard
Bus terminator	2282675	Standard

### Service Kit—Feature Code 2505 (PN 85H7923)

The optional service kit provides wrap plugs for most of the 2216 base interfaces. The wrap plugs cannot be purchased individually. You must purchase the entire kit.

## Wrap Test and Terminator Plugs

Table 3-2. 2216 Base Adapter Wrap Plugs

Adapter LIC	FRU PN	Feature Code	Description	Wrap Plugs
280	85H5543 & 02L1873	2280	2-Port Token-Ring	UTP 04H8210
281	85H5542 & 02L1872	2281	2-Port Ethernet	UTP 04H8210 BNC 02G7433
282	85H4872	2282	8-Port EIA 232	CRD 68F7208 CBL 33F8985
283	85H4882 & 02I2065	2283	1-Port ISDN PRI (T1)	57G8097
284	85H4894	2284	1-Port 155-Mbps (MMF ATM)	16G5609
286	86H0967	2286	1-Port FDDI	Two - 16G5609
287	85H4878	2287	1-Port ESCON Channel	5605670 fiber-optic jumper cable 14F3797
288	86H1005	2288	1-Port 10/100-Mbps Ethernet	21H4811
289	85H9703	2289	1-Port HSSI	30L6386 for Adapter 30L6385 for Cable
290	85H4874	2290	6-Port V.35/V.36	CRD 72F0168 V.35 BRICK 72F0167 V.36 CBL 73H2508
291	85H4876	2291	8-Port X.21	CRD 06H3357 CBL 52G3378
292	85H4884 & 02L2066	2292	1-Port ISDN Pri (E1)	57G8097
293	85H6834	2293	1-Port 155-Mbps (SMF ATM)	16G5609
294	86H0986	2294	1-Port 155-Mbps (MMF ATM)	16G5609
295	86H0993	2295	1-Port 155-Mbps (SMF ATM)	16G5609
297	02L2331	2297	4-port ISDN PRI/Channelized (T1)	25L4749
298	02L2333	2298	4-port ISDN PRI/Channelized (E1)	25L4749

### LIC 282, LIC 290, and LIC 291 External Wraps

Figure 3-1 and Figure 3-2 on page 3-4 show the wrap plug locations for LICs with multiple wrap plugs.

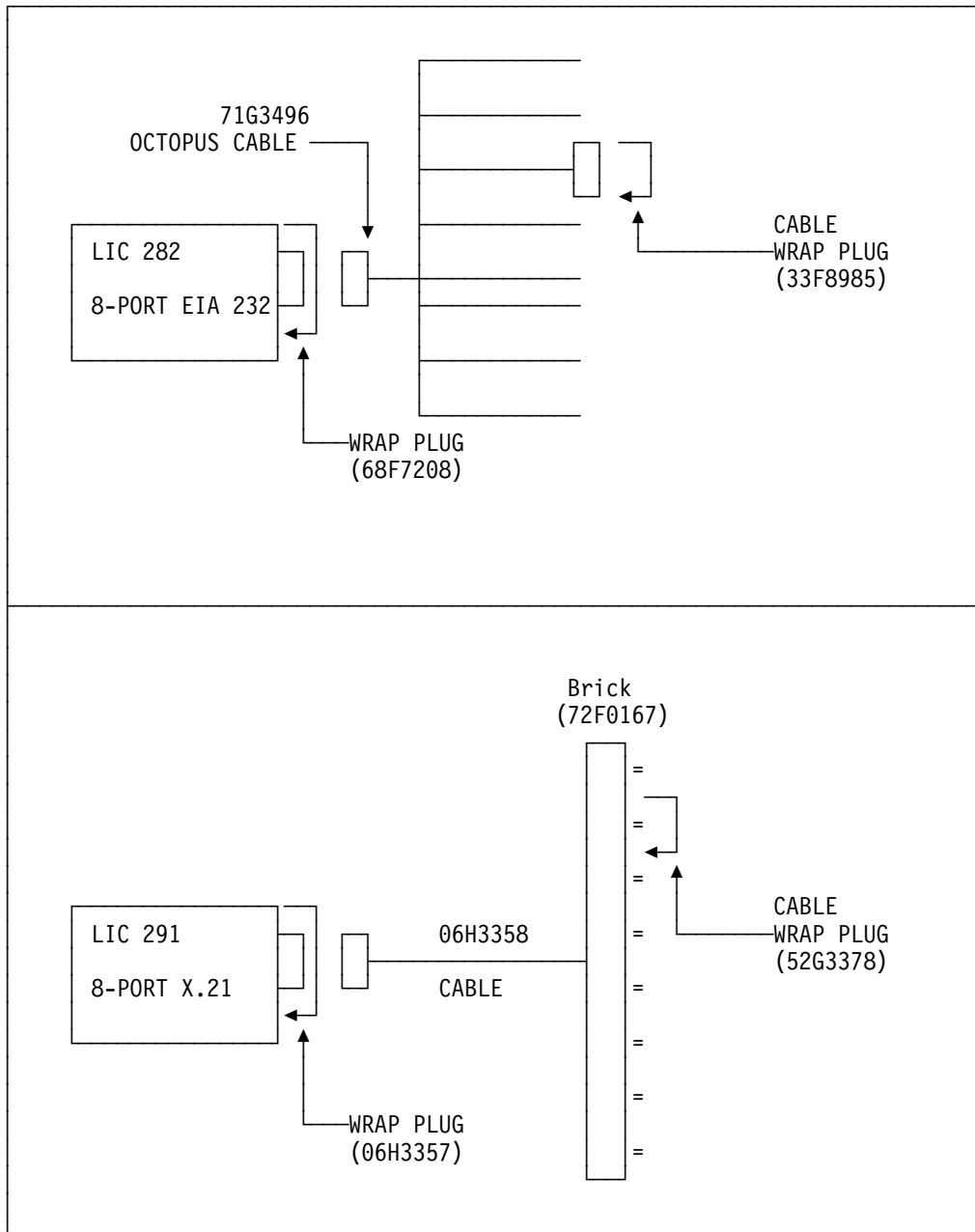

Figure 3-1. LIC 282 and LIC 291 Wrap Support

# Wrap Test and Terminator Plugs

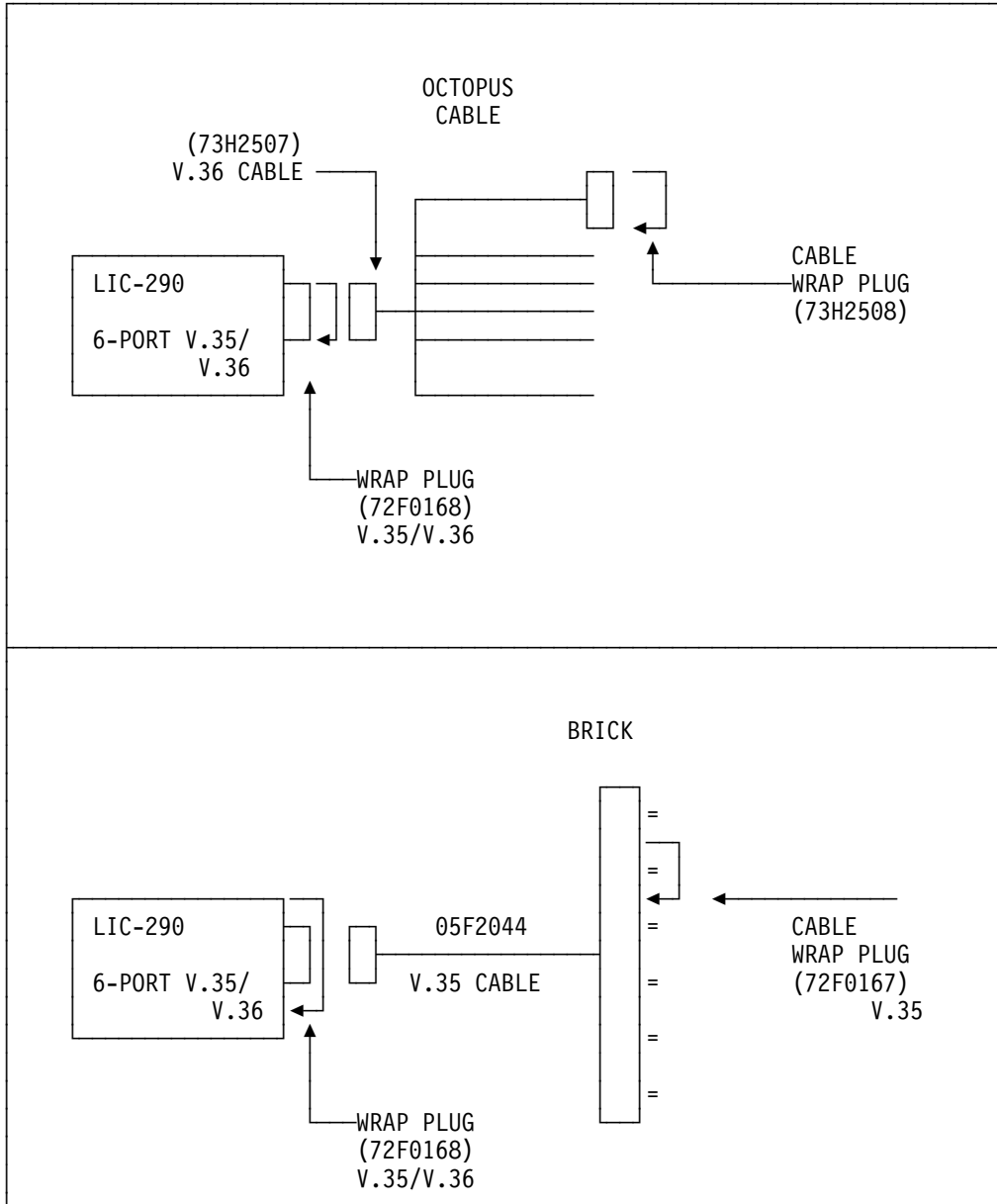

Figure 3-2. LIC 290 Wrap Support

---

### External Wrap Testing Parallel Channel Adapters

**Note:** This procedure requires a channel- trained IBM service representative or customer's channel- trained person.

Throughout this section, any reference to 2216 denotes usage for the 2216 Model 400 or for the Network Utility Model TX1 or TN1.

This section explains the basic concepts for preparing the channels for testing, contains rules governing channel attachment, and provides procedures for preparing the wrap blocks. When you are certain about your configuration, follow the procedures in this section.

**Attention:**

- **Do not** unplug the cables unless all the device addresses that are attached to the channel have been varied offline.
- **Do not** remove the cables unless necessary. Removing and reattaching bus and tag cables can cause pins to bend.
- Run diagnostic option 2 with a wrap block when:
  1. You are installing a Parallel Channel Adapter as an upgrade
  2. There is still an indication of a Parallel Channel Adapter channel error and you have already run diagnostic option 1 and it ran cleanly.

### Concepts

When testing the Parallel Channel Adapters with wrap blocks, follow the procedures to ensure that all channels affected by your test remain operational.

1. First trace the V-cables and the Channel Interface Cables from the Parallel Channel Adapters that you are testing to their input and output connectors.
2. Even if you are not testing additional Parallel Channel Adapters in the IBM 2216, trace the V-cable attached to the additional adapters to their input and output connectors.
3. Sketch your configuration, if necessary, to be sure that you know how the adapters are attached to the channels.

### Rules for Parallel Channel Adapter Testing

Prepare the channel cables, other V-cables, and the other Channel Interface Cables so that the channel can be operational while you are testing the adapter. To preserve all channels to the host that might be affected by your test, follow these rules:

1. Be sure to vary the channel offline (make the channel inoperational).
2. When setting up the wrap test maintain a terminated channel path to the host as shown in Figure 3-3 on page 3-6 and Figure 3-4 on page 3-7.
3. If you want the channel to be online while doing wrap tests, vary the channel online after preparing the wrap test connections.
4. Perform the wrap tests that you need to perform.
5. Reconnect your cables according to the sketch that you made.

## Preparing the Wrap Blocks

The procedures you follow to install wrap blocks depend upon the following conditions:

- V-cable interconnected configurations
- Interconnection of multiple adapters in a single IBM 2216
- Interconnection of multiple adapters among IBM 2216s
- Options for testing the adapters in a single IBM 2216, individually or together.

Install wrap blocks. Remember your configuration and refer to the sketch you made:

- When you are testing a Parallel Channel Adapter in a **single IBM 2216 at the end of a channel**, follow these steps using the following figure:

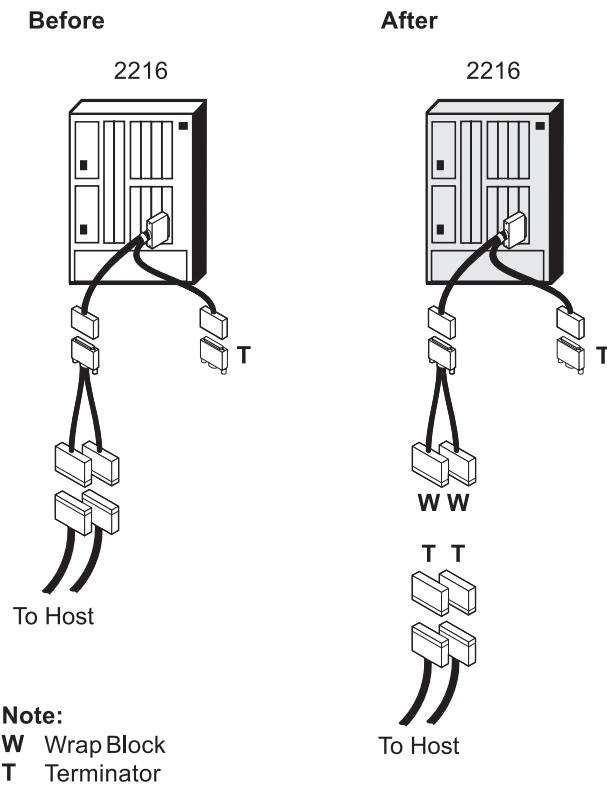

Figure 3-3. Single Parallel Channel Adapter at the End of a Channel

1. Unplug the channel cables from the Channel Interface Cables of the Parallel Channel Adapters that you are testing.
2. Insert the bus and tag wrap blocks into the bus-in and tag-in ends of the Channel Interface-in cable, and the V-cable terminator.
3. If you want to put the channel in the operational state while you are testing the adapter, insert bus and tag terminators on the ends of the associated bus and tag channel cables.
4. Go to Step 4 on page 3-14.



## Parallel Channel Wrap Testing (Channel Trained Personnel Only)

- When you are testing **one Parallel Channel Adapter that is interconnected to an IBM 2216 with a single Parallel Channel Adapter**, use the figure to determine how you want to connect your cables, and go to step 1 on page 3-8.

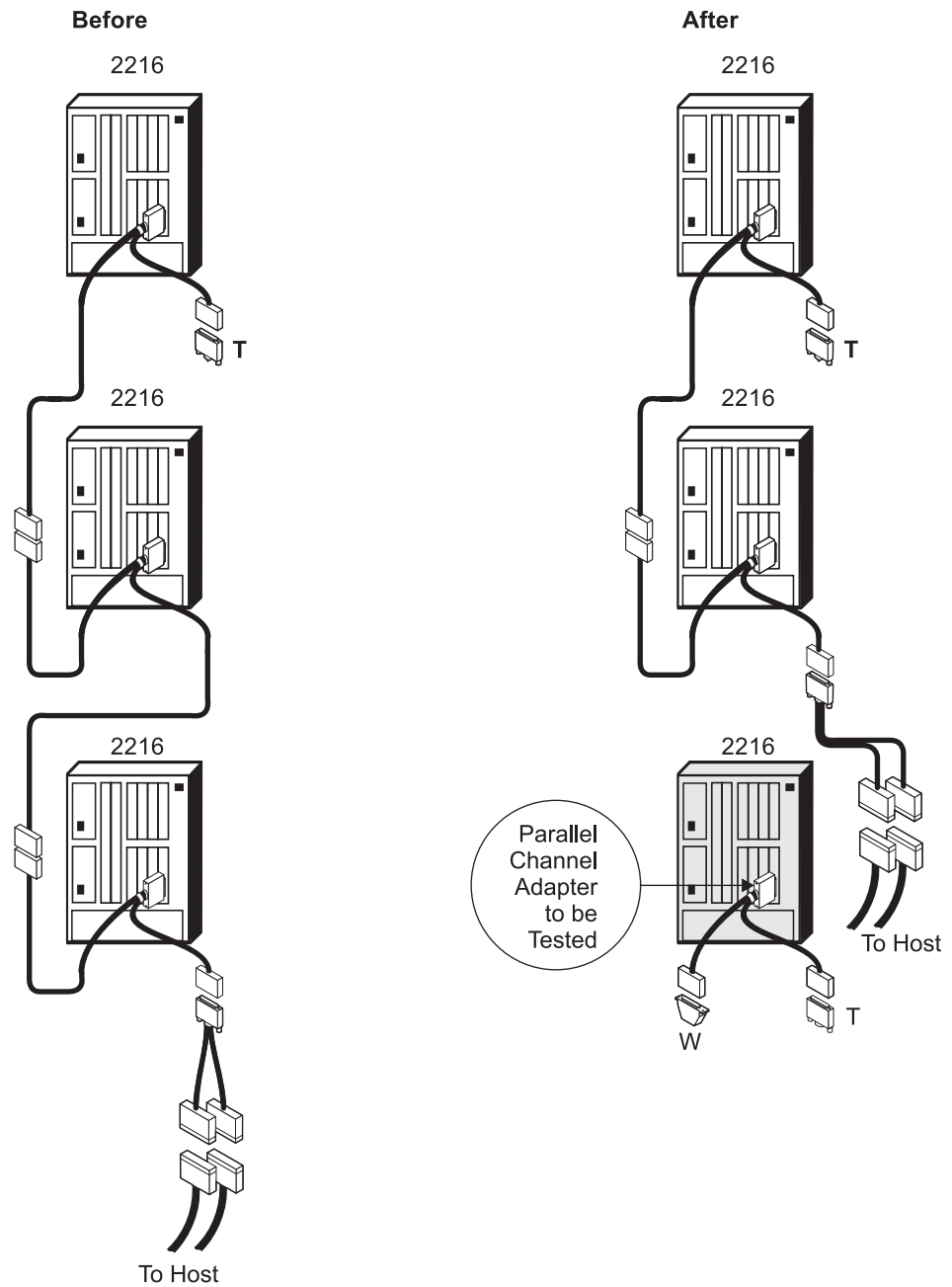

**Note:**

W Wrap Block

T Terminator

Figure 3-4. Interconnected Parallel Channel Adapters

## Parallel Channel Wrap Testing (Channel Trained Personnel Only)

Use the following when wrap testing interconnected Parallel Channel Adapters:

1. Are you testing a Parallel Channel Adapter that is interconnected with v-cables to other Parallel Channel Adapters?

**Yes** Plug the two single ends of the V-cable from the Parallel Channel Adapters that are not being tested together to bypass the middle Parallel Channel Adapter. Continue with Step 2.

**No** Plug the single V-cable end of the Parallel Channel Adapter that is not being tested into the Parallel Channel Adapter that is connected to the host. Continue with Step 2.

2. Plug both ends of the V-cable of the adapter that you are testing into unused Channel Interface Cables.
3. Insert wrap blocks and terminators into the cables that you are testing.
4. Return to "Running the Parallel Channel Adapter External Wrap Tests" on page 3-9.

## Running the Parallel Channel Adapter External Wrap Tests

Use the external wrap tests to locate problems with the cables. Test the cables only after verifying the adapter is functional by running the online diagnostics of the adapter (see “Running Diagnostics on the Adapter” on page 9-8).

Run the Parallel Channel Adapter test with the wrap blocks and terminators. This tests the Parallel Channel Adapter, the V-cable, and the Channel Interface Cables.

Run external wrap tests of the adapter and the cables in the following sequence:

1. The adapter, see Figure 3-5
2. V-cable, see Figure 3-6 on page 3-10
3. V-cable and the Channel Interface-in, see Figure 3-7 on page 3-11
4. V-cable, Channel Interface-in, and Channel Interface-out, see Figure 3-8 on page 3-12
5. V-cable and Channel Interface-out, see Figure 3-9 on page 3-13

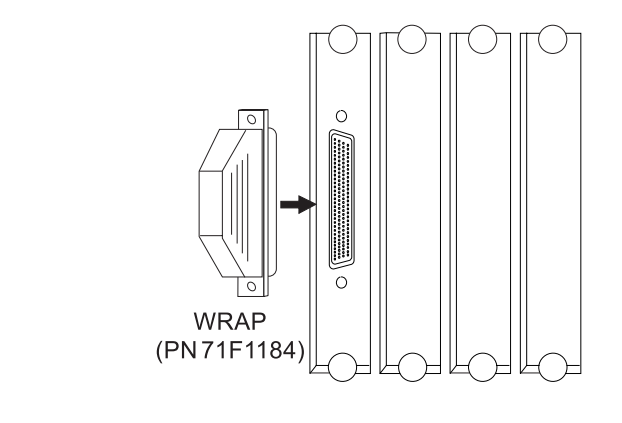

Figure 3-5. Adapter Wrap Test Connection

# Parallel Channel Wrap Testing (Channel Trained Personnel Only)

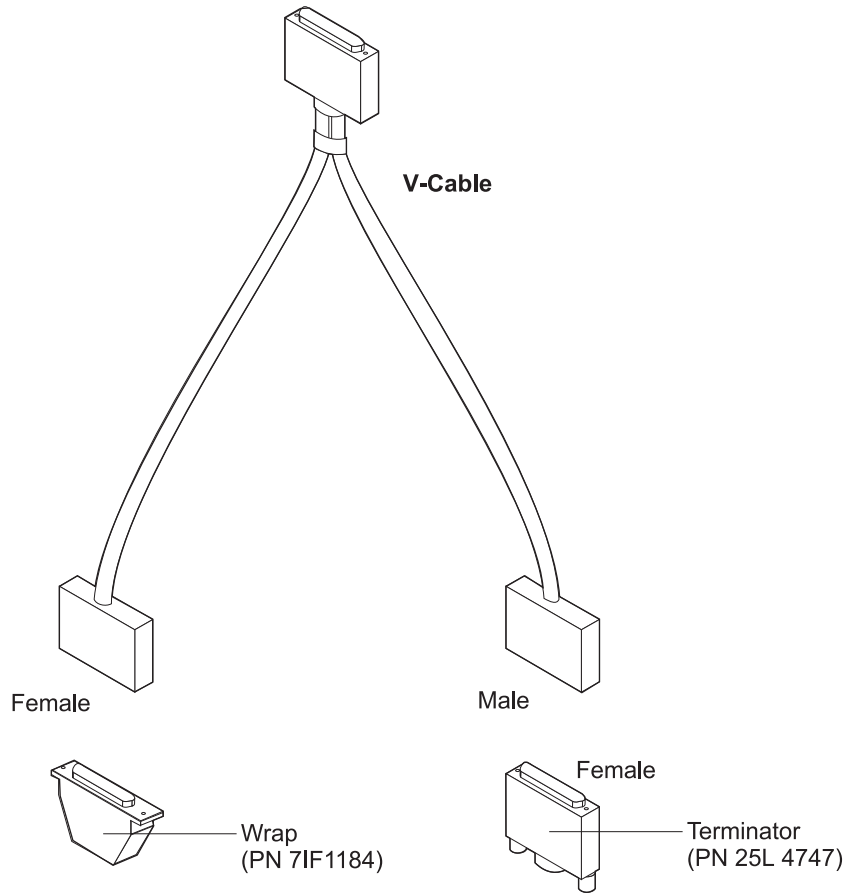

Figure 3-6. V-cable Wrap Test Connections

# Parallel Channel Wrap Testing (Channel Trained Personnel Only)

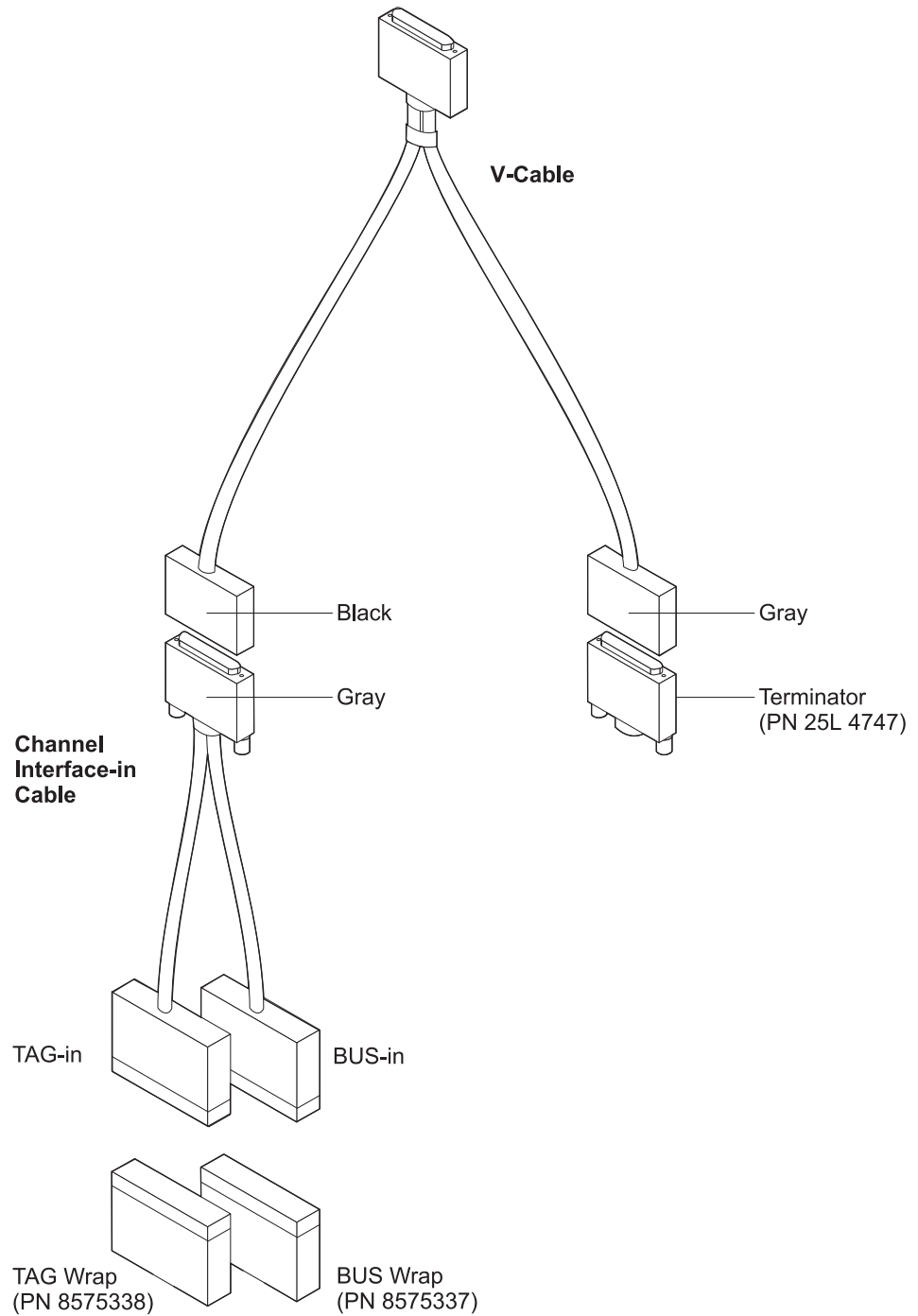
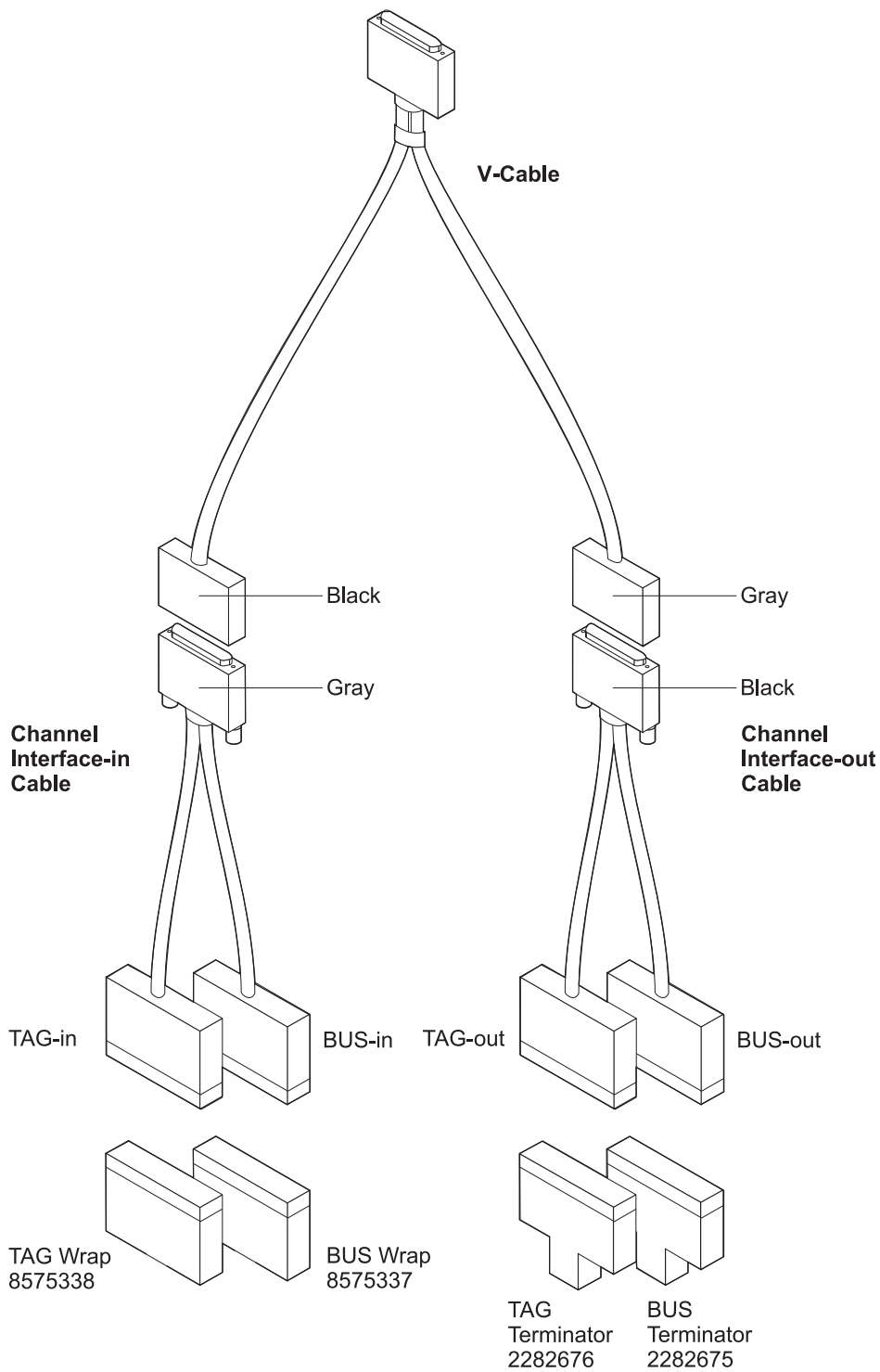

Figure 3-7. Channel Interface-in Wrap Test Connections

**Parallel Channel Wrap Testing (Channel Trained Personnel Only)**



*Figure 3-8. All Cables Wrap Test Connections*

# Parallel Channel Wrap Testing (Channel Trained Personnel Only)

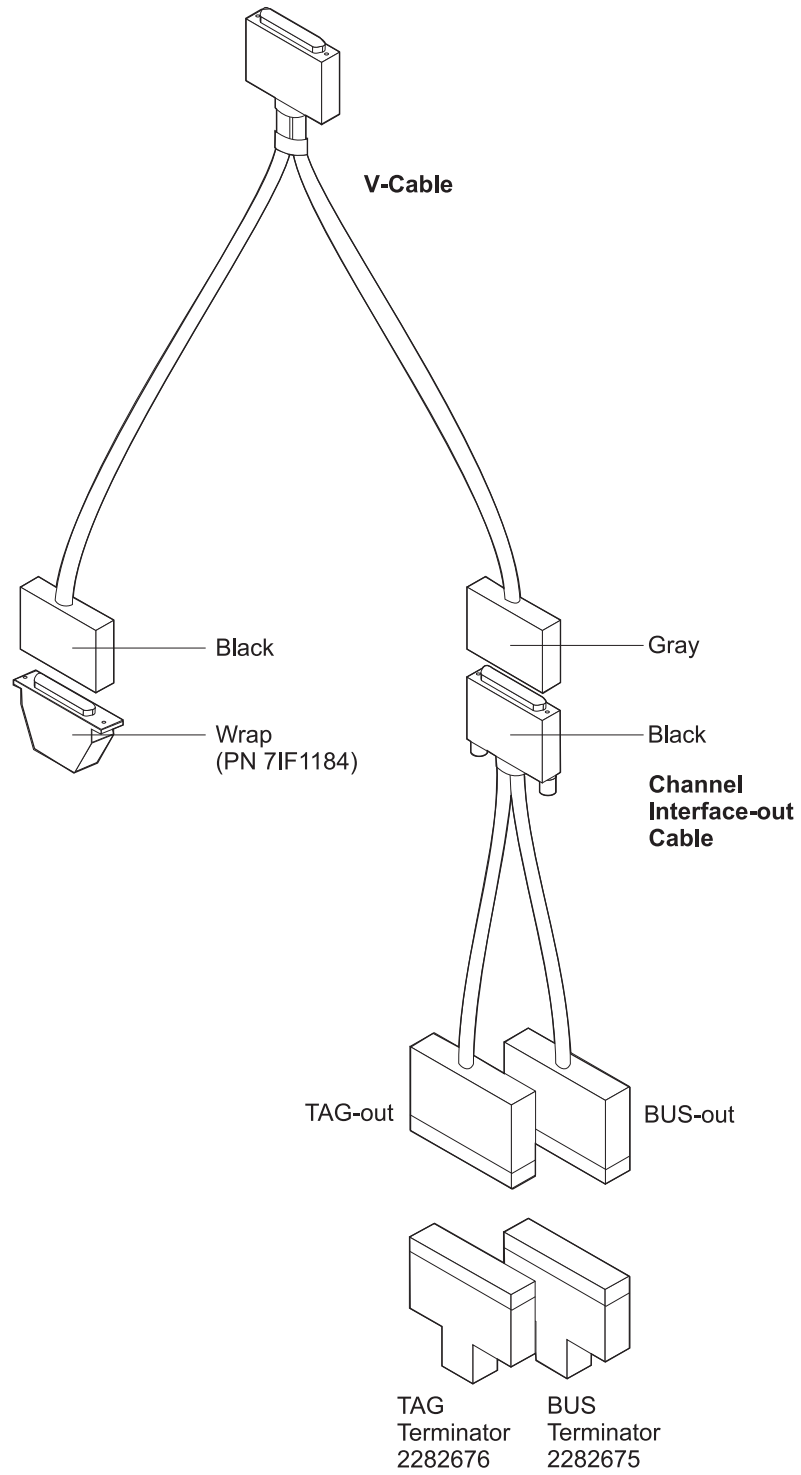

Figure 3-9. Channel Interface-out Wrap Test Connections

## Parallel Channel Wrap Testing (Channel Trained Personnel Only)

To run the Parallel Channel Adapter test with the wrap blocks, which includes a test of the V-cable and the Channel Interface Cables, follow these steps:

1. Leave the V-cable attached to the adapter.
2. Ask the host computer operator to vary offline all device addresses attached to the channel that contains the adapter that is to be tested. This is required because the channel cables will be unplugged, which could cause host problems.
3. Prepare the channel cables, V-cables, Channel Interface Cables, wrap blocks, and terminators. See "External Wrap Testing Parallel Channel Adapters" on page 3-5.
4. After the cable preparation is complete, ask the host computer operator to vary online those units attached to channels that are **not** being tested.
5. Run the diagnostic test (see "Testing the Adapters" on page 9-7).
6. Do you want to repeat the Parallel Channel Adapter test?

**Yes** Return to Step 3 to test the next cabling scenario until you are done.

**No** Perform the following steps:

- a. Ask the host computer operator to vary offline all device addresses attached to the channels you tested.
- b. Make sure that all Select/Bypass Switches that are connected to Parallel Channel Adapters are set to **S**.
- c. Remove the wrap blocks and extra terminators.
- d. Reconnect the channel cables to their correct locations.
- e. Ask the host computer operator to vary online all device addresses attached to the channels you tested.
- f. Return to the procedure you were following.



---

## Chapter 4. Removal and Replacement Procedures

This chapter provides preparatory information that applies to all the removal and replacement procedures (see “Before You Start”).

See the following sections to remove or order parts:

- **For the 2216 Model 400:**
  - Descriptions of the individual FRU removal and replacement procedures (see Chapter 5, “Model 400 FRU Exchange” on page 5-1).
  - Overall perspective on the FRUs and their positioning relative to each other and the chassis, see Appendix B, “Parts Listings” on page B-1.
- **For the Network Utility:**
  - Descriptions of the individual FRU removal and replacement procedures (see Chapter 6, “Model TX1 or TN1 FRU Exchange” on page 6-1).
  - Overall perspective on the FRUs and their positioning relative to each other and the chassis, see “Assembly 2: Final Assembly, 2216 - Model TX1 or TN1” on page B-4.
- **For all models:**
  - See “Installing and Removing Channel Adapters” on page 4-3.

---

### Before You Start

Before you begin any removal or replacement activity, review the list of equipment you will need, read the common safety precautions and then proceed.

### Equipment You Need

You need the following equipment to remove and replace the FRUs in the IBM 2216:

- 7-mm nut driver
- 5/32-inch nut driver
- Flat-blade screwdriver
- Screw starter (optional)

### Safety Precautions

#### DANGER

**To avoid a shock hazard, do not connect or disconnect any cables or perform installation, maintenance, or reconfiguration of this product during an electrical storm.**

**Note:** For translations of this safety notice, see Appendix H, “Safety Information” on page H-1.

## Disconnecting the Power Cord

**Note:** Disconnecting the power cord will disrupt users in your network. Consult the network administrator before disconnecting the power cord.

Disconnect the power cord from the ac power outlet and then from the IBM 2216.

**Where to Go Next:** If you are replacing the power cord, continue with Reconnecting the Power Cord.

## Reconnecting the Power Cord

### DANGER

**To avoid shock hazard:**

- **The power cord must be connected to a properly wired and grounded receptacle.**
- **Any equipment to which this product will be attached must also be connected to properly wired receptacles.**

**Note:** For translations of this safety notice, see Appendix H, "Safety Information" on page H-1.

Connect the power cord to the IBM 2216 and then to the ac power outlet.

## Installing and Removing Channel Adapters

This section explains how to perform channel adapter installation and replacement, and shows how to connect and install the cables for the channel adapters.

**Note:** This procedure requires a channel-trained IBM service representative or customer's channel-trained person. Throughout this section, any reference to 2216 denotes usage for the 2216 Model 400 or for the Network Utility.

## Parallel Channel Attachment

Up to six 2216 base Parallel Channel Adapters can be attached to a single channel. When the channel is configured for 4.5 MB Data Streaming, the 2216 base Parallel Channel Adapter must be at the end of the channel.

The adapter attaches to the channel with the Channel Interface Cable group (*V-cable and two unique optional-order Channel Interface Cables*). Figure 4-3 on page 4-5 shows how the cables attach to the channel.

The V-cable, as shown in Figure 4-1, has a Select/Bypass Switch with settings of **S** and **B** that are used to select or bypass this adapter, respectively.

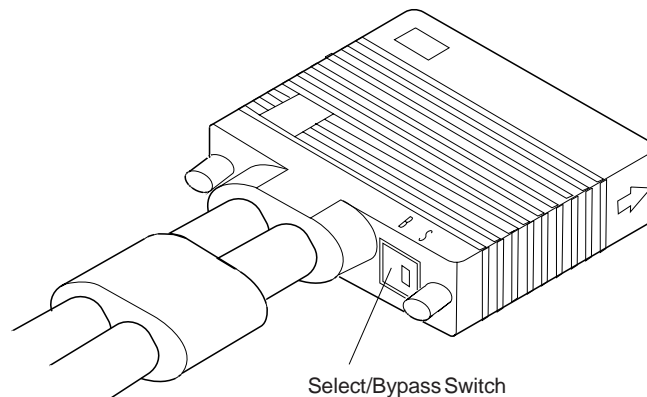

Figure 4-1. Select/Bypass Switch on V-Cable

### Attention:

- During testing and installation, you may be instructed to use the Select/Bypass Switch to bypass the adapter you are working on.
- Be sure to ask the host operator to vary the channel off before you use the switch so that you will not disrupt the channel.

The cables are designed so that you can interconnect them in a serial fashion to form a channel path. This enables you to connect several adapters without each adapter connecting to a bus and tag channel cable.

The last Parallel Channel Adapter in the series must be terminated using either the 2216 base specific channel terminators (PN 25L4747), or Channel Interface-out with standard bus and tag terminators. "Using Interconnected V-Cables" on page 4-8 explains the concepts regarding Parallel Channel Adapter interconnecting.

# Parallel Channel Adapter Install/Removal (Channel Trained Personnel Only)

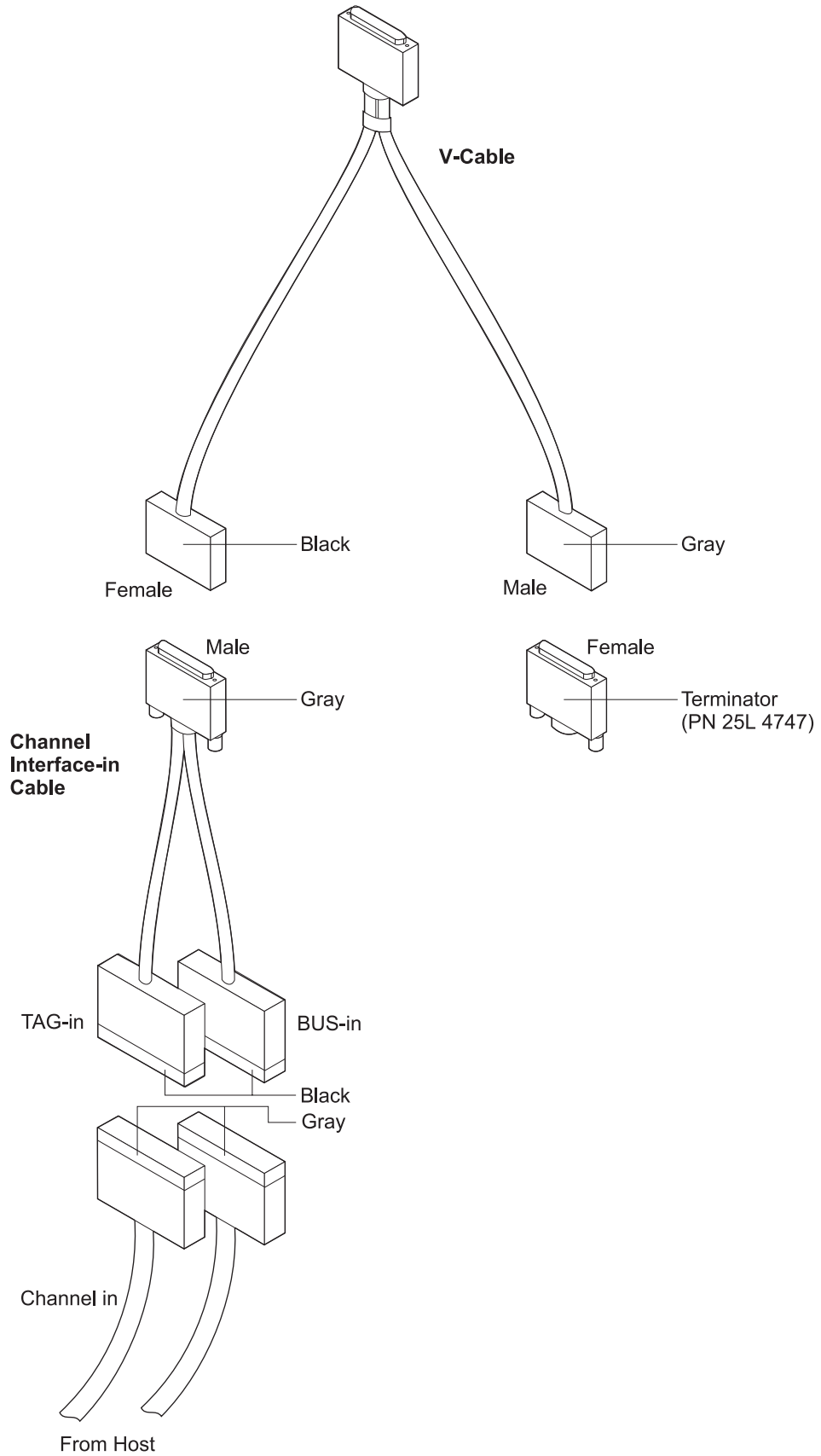

Figure 4-2. Cabling to IBM 2216 at the End of Channel

# Parallel Channel Adapter Install/Removal (Channel Trained Personnel Only)

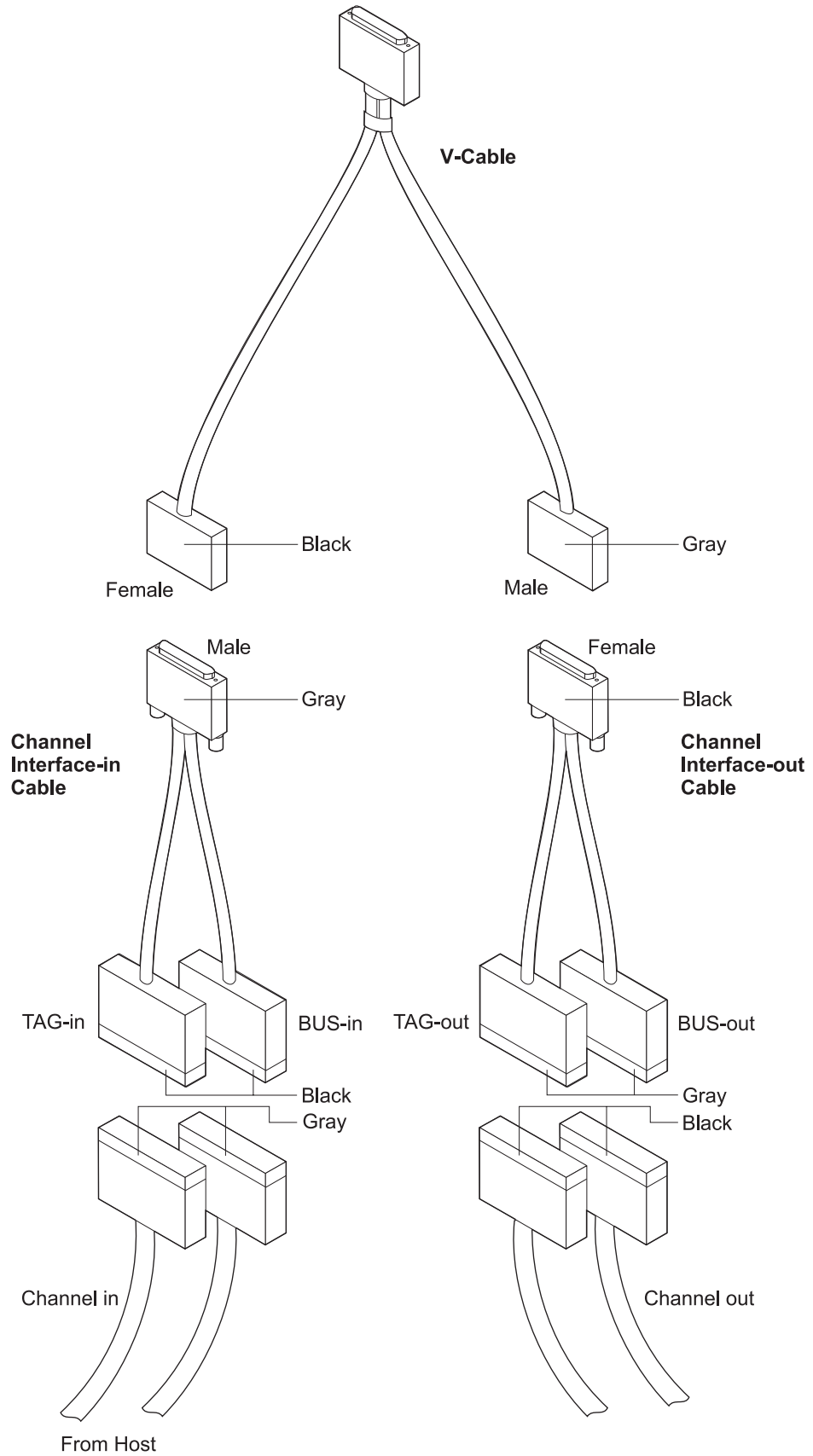

Figure 4-3. Cabling to IBM 2216 in the Middle of the Channel

# Parallel Channel Adapter Install/Removal (Channel Trained Personnel Only)

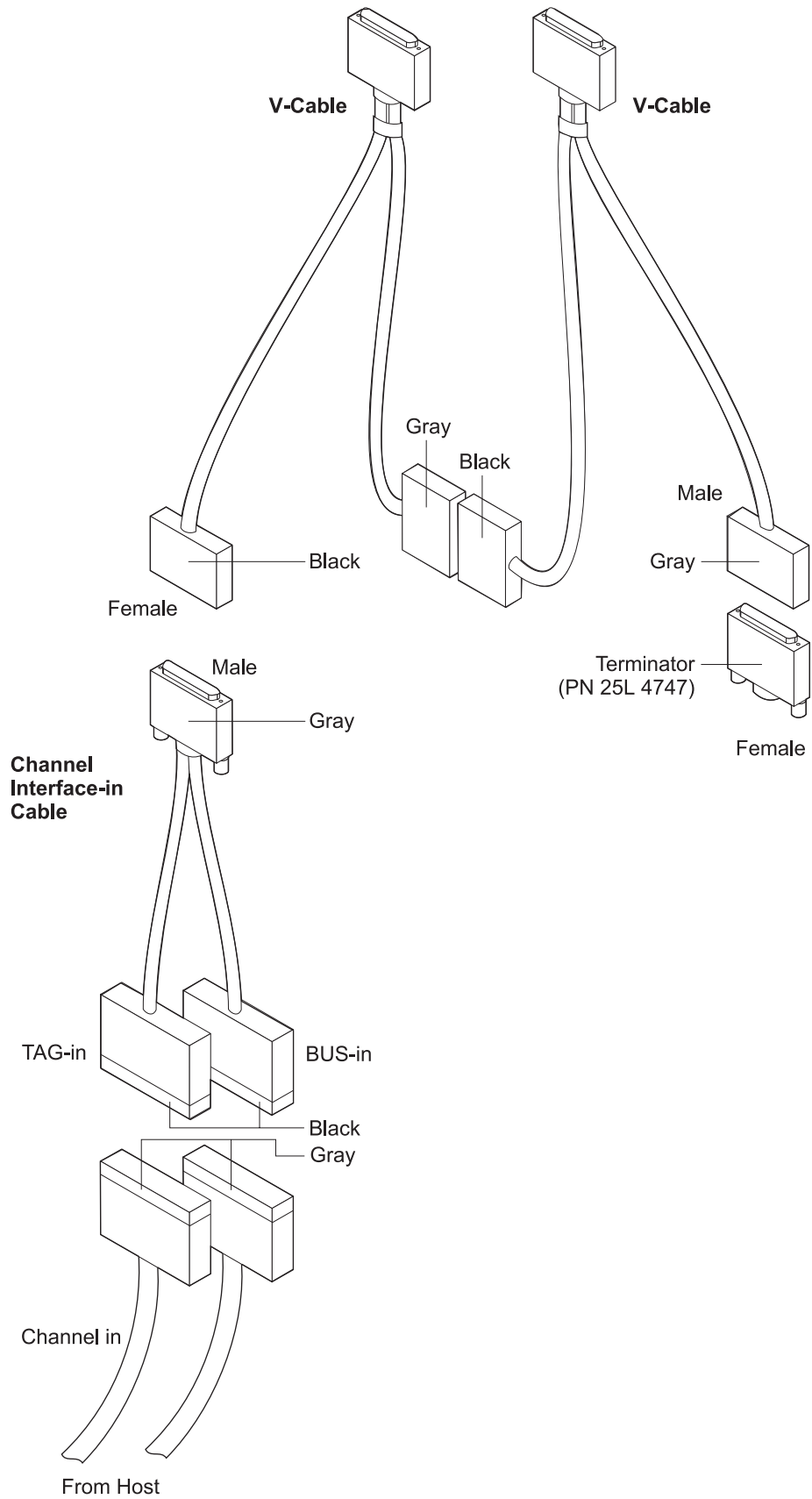

Figure 4-4. Interconnected V-cables

## Parallel Channel Adapter Install/Removal (Channel Trained Personnel Only)

### V-Cables

Use only v-cable PN 02L2074 with the 2216 base Parallel Channel Adapter.

Use the following rules for correct parallel channel attachment:

- A maximum of six Parallel Channel Adapters (including any 3172 Model 3s) can be attached to the same channel.
- The V-cable does not have to be interconnected to other Parallel Channel Adapters and can be located anywhere on the channel, provided that all other 4.5-MB devices are attached between the 2216 base Parallel Channel Adapters (or 3172 Model 3s) and the host.

**Note:** There is a possibility of interconnecting 2216 base Parallel Channel Adapters to 3172 models. The following rules would apply in this case:

1. The 2216 base Parallel Channel Adapters can connect only to V-cables PN 33G3056 or PN 02L2074 (and no other).
2. V-cable PN 25F9397 (used on early 3172 Model 1s) **cannot** be used.

### Channel Interface Cables

The Channel Interface Cables are two distinct cables. They are not interchangeable. The following figure shows the cables. Use the colors on the connectors on the cables to distinguish the differences between the cables.

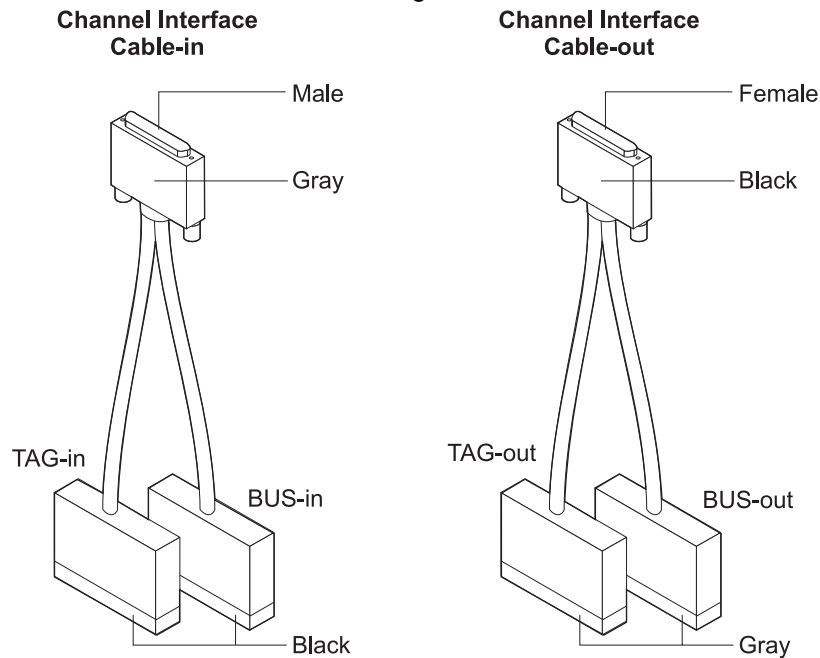

## Using Interconnected V-Cables

The standard 2216 base Parallel Channel Adapter connection to a channel is a 1.8 m (6 ft) V-cable and two unique Channel Interface Cables (see Figure 4-2 on page 4-4 and Figure 4-3 on page 4-5). However, multiple adapters can be interconnected in a serial fashion by connecting cables as shown in the figures that follow.

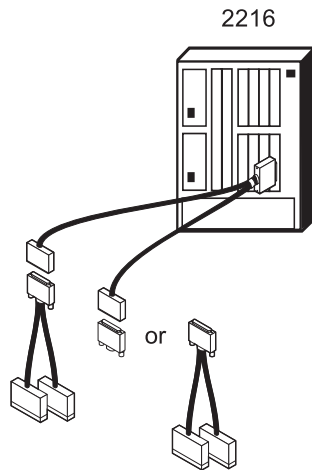

Figure 4-5. Standard Channel Connection

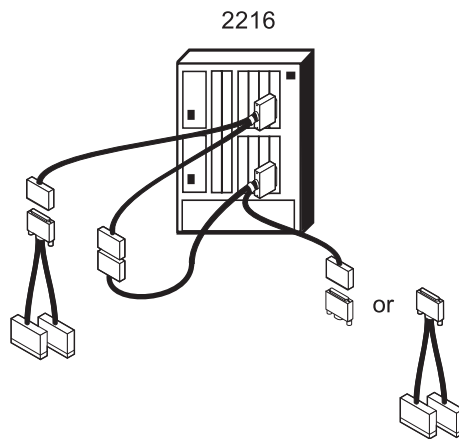

Figure 4-6. Two Adapters Attached to One Channel

### Notes:

1. For the Network Utility, each Parallel Channel Adapter must be in a separate Network Utility.
2. For the Model 400, the Parallel Channel Adapters can be in separate Model 400s.



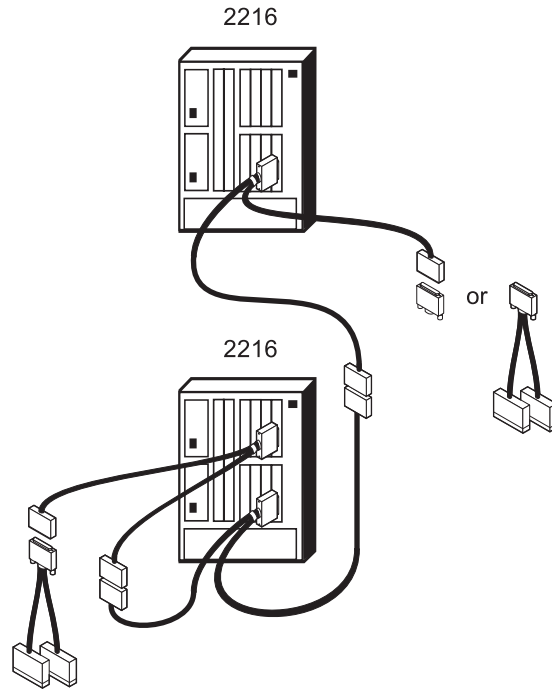

Figure 4-7. Three Adapters Attached to One Channel

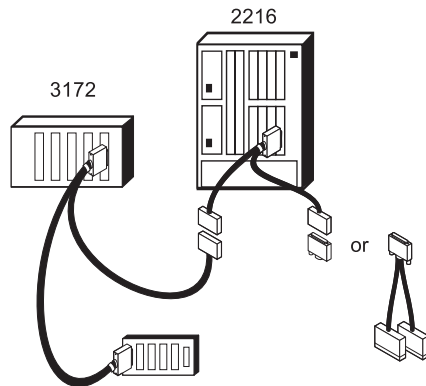

Figure 4-8. IBM 2216 Parallel Channel Adapter on a Channel with a 3172 Connected to a Channel Interface Assembly

## Installing Channel Feature 2299

**Note:** Use the field electrostatic discharge (ESD) kit when you are handling adapters. Guidelines for using the ESD tools are included inside the kit.

1. For the Model 400, verify that the new feature (and feature code) you are installing to make sure that the customer's adapters are supported. The feature code appears on the Bill of Materials included with the miscellaneous equipment specification (MES) under the heading "Bill Title."

Because many adapter types are supported, only certain combinations are valid. You might be trying to add an MES that requires another adapter to be moved to a different slot or removed from the IBM 2216.

## Parallel Channel Adapter Install/Removal (Channel Trained Personnel Only)

To verify this, do the following:

- a. Verify the availability of an empty slot for the adapter installation, using “Model 400 Slots and Adapters” on page E-1.
  - b. If an empty slot is not available, move an existing adapter to another slot before installing the new feature, or remove an existing adapter to accommodate the new feature. Removal of adapters must be coordinated with the customer. The customer must decide which feature is to be removed.
2. Select the slot in which to install the adapter.
  3. If there is a filler panel in the slot that you want to use, loosen the retainer screw on the filler panel for that slot. Slide the filler panel up and remove it. Store it where you can find it to reinstall if you ever remove this adapter.

## Parallel Channel Adapters Installation and Removal

Use the following information after being directed to this section from “Exchanging an Adapter” on page 5-14.

To install or remove channel adapters, follow the directions in this section. Repeat these directions for each channel adapter that you are installing or removing.

### Installing Channel Adapters

To **replace or install** a Parallel Channel Adapter, complete the following steps:

1. Insert the V-cable straight into the Parallel Channel Adapter D-shell connector.
2. Tighten the screws on the top and bottom of the connector.

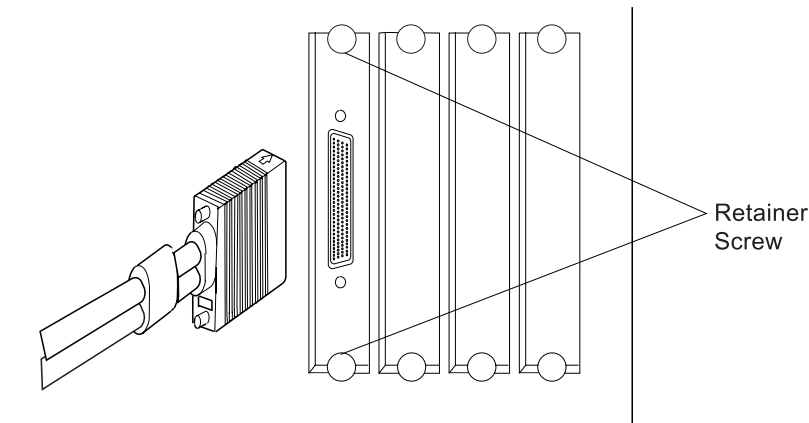

3. Ask the host computer operator to place the channel attached to this Parallel Channel Adapter in a non-operational state.

## Parallel Channel Adapter Install/Removal (Channel Trained Personnel Only)

4. Remove the protective covers from the ends of the Channel Interface Cable connectors (if present).
5. Touch the connectors of the Channel Interface Cables and the channel cables to the grounding pad (PN 31G8908) before continuing.
6. Use Figure 4-2 on page 4-4, Figure 4-3 on page 4-5, and Figure 4-4 on page 4-6 as reference to continue the next steps. Connect the Parallel Channel Adapter cables beginning at the host channel cable.
7. If you are installing the optional Channel Interface-in cable, connect the:
  - a. Channel Interface-in bus and tag cables to the channel cables that come from the host side of the channel.

**Attention:** To prevent bending the pins, draw the cables together by tightening the screw.

Lay the cables on a flat surface and draw the cables together by tightening the screw near the center of the channel cable as shown.

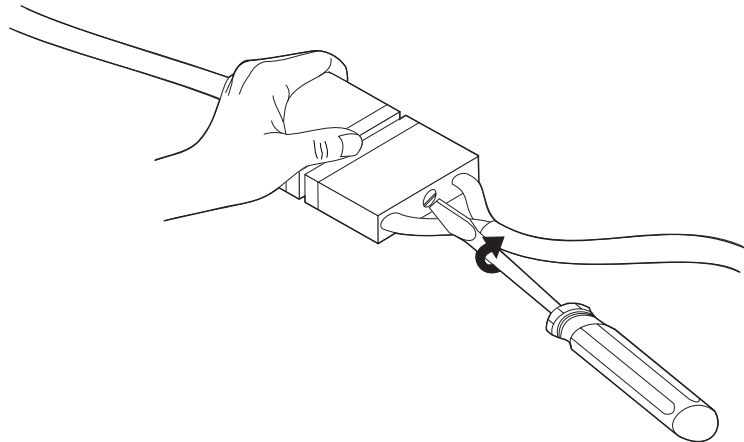

8. Connect the:
  - a. Channel Interface-in cable to the V-cable
  - b. V-cable to the adapter (if you have not already done this in a previous step)
  - c. V-cable to the IBM 2216 specific terminator, OR
    - V-cable to the Channel Interface-out cable
    - Bus and tag-out from Channel Interface-out cable to the associated bus and tag terminator (or to the next channel cables)
9. See "Routing the Adapter Cables through the Cable Guides" on page 4-17 for information about routing new cables.
10. Move the Select/Bypass Switch on the V-cable to **S**.

**Note:** When the Select/Bypass switch is set to **B**, the Parallel Channel Adapter is bypassed on the attached channel.

The Select/Bypass Switch must be set to **S** prior to restarting your host application.

## Parallel Channel Adapter Install/Removal (Channel Trained Personnel Only)

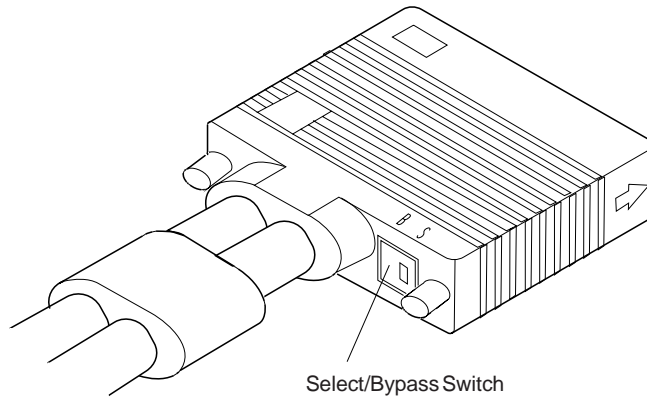

Figure 4-9. Select/Bypass Switch on V-Cable

11. Run diagnostic tests (see "Testing the Adapters" on page 9-7) to verify that the adapter and cables are OK.
12. Tell the host computer operator that the channel can be returned to an operational state.
13. Return to the procedure that brought you here.

### Removing Channel Adapters

**Note:** Perform the following procedure only after being directed to this section from “Exchanging an Adapter” on page 5-14.

To **remove** a Parallel Channel Adapter, do the following:

1. Ask the host computer operator to place the channel attached to this Parallel Channel Adapter in a non-operational state.
2. Disconnect the V-cable from the Parallel Channel Adapter, by loosening the screws on the top and bottom of the connector.
3. Pull the connector on the cable from the D-shell connector on the adapter.

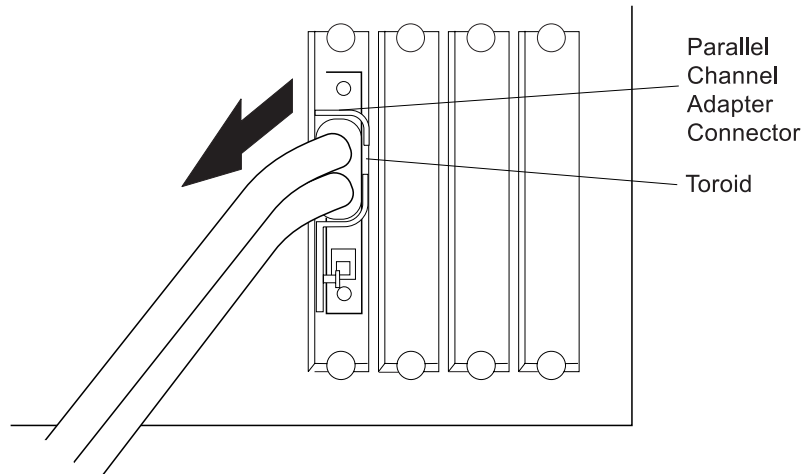

4. Move the Select/Bypass Switch on the V-cable to **B**.

**Note:** When the Select/Bypass switch is set to **B**, the Parallel Channel Adapter is bypassed on the attached channel.

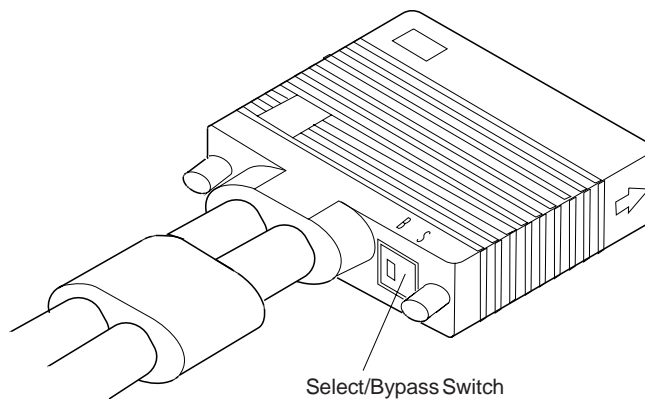

5. Tell the host computer operator that the channel can be returned to an operational state.
6. Return to the procedure that brought you here.

## ESCON Channel Adapter Cable Installation

To install the optical fiber cables or the V-cable, follow the directions in this section. Repeat the steps for each cable you are installing.

### Installing Optical Fiber Cables

The ESCON connector has a protective cover on the pronged end. The protective cover does not need to be removed for operation.

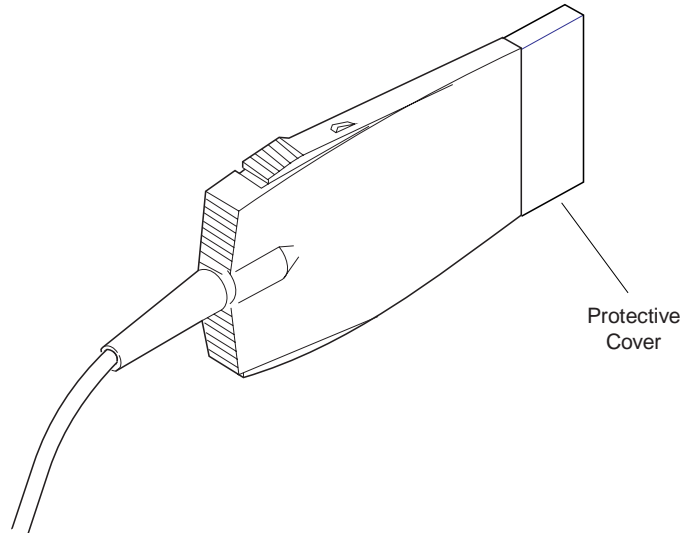

1.

Table 4-1. ESCON Cables

Connect	Disconnect
To connect the adapter cables to the <b>ESCON Adapter</b> , push the connector into the adapter connector until it clicks.	To disconnect the <b>ESCON Adapter</b> cable from the adapter connector, squeeze tabs on the top and bottom of the connector and remove it from the adapter connector.

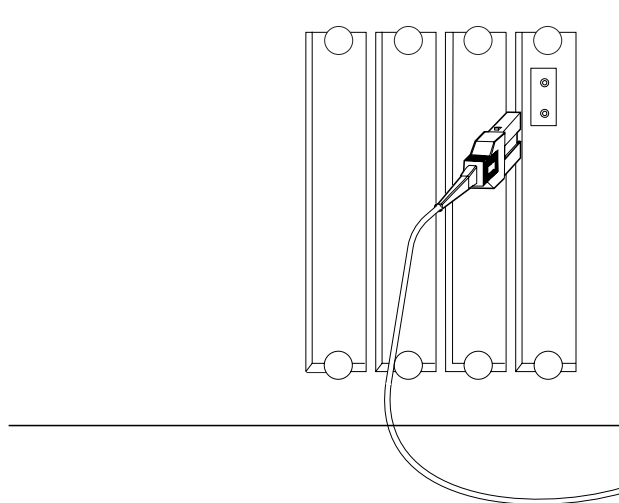

**Note:** When fastening optical fiber and other cables together using the same cable tie, be careful not to fasten the tie too tightly. Overtightening the ties can damage the optical fiber cable. Whenever possible, fiber optic cables should be routed separately from wire-based cables.

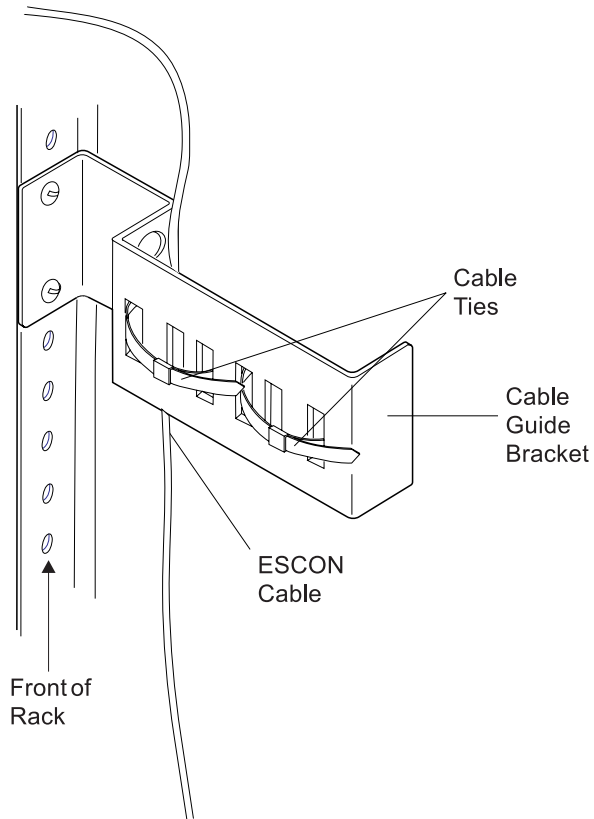

2. Use tape or a marker to label the cable.

## Channel Interface Cable Replacement Procedure

**Note:** Before starting this procedure, ask the host computer operator to place the channel that is attached to this Channel Interface Cable into a non-operational state.

### Removing a Channel Interface Cable

To remove a Channel Interface Cable, follow these steps:

1. Ask the host computer operator to vary the channel off, which places the channel connected to the Channel Interface Cable in a non-operational state.

**Note:** The channel will remain in that non-operational state until the cable work is completed.

2. Remove each channel cable (or terminator block) from the Channel Interface Cable. If you are replacing the Channel Interface Cable, note the location of each cable or terminator block so that you can easily transfer it to the new Channel Interface Cable. (The channel ends of the Channel Interface Cables are labeled for bus and tag.)

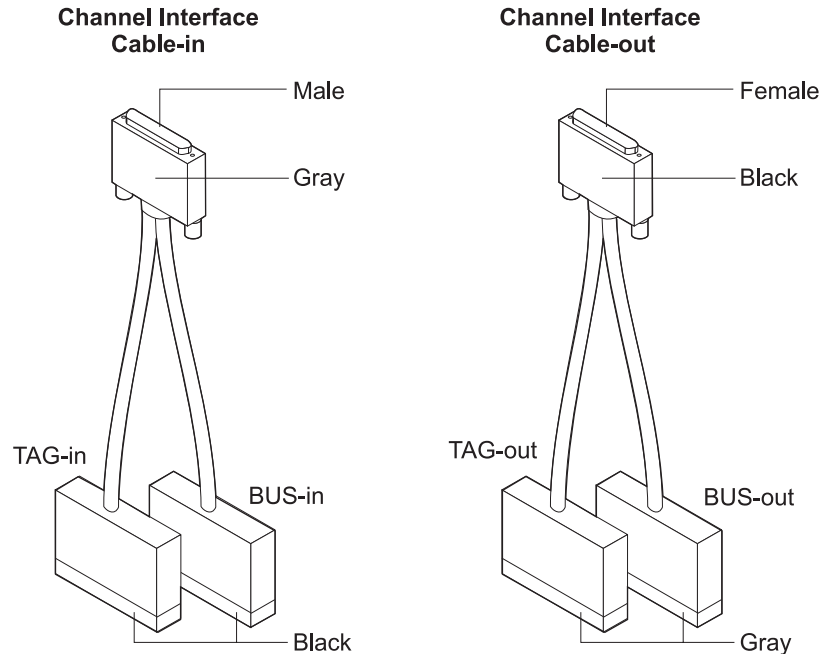

### Reinstalling the Channel Interface Cable

To reinstall the Channel Interface Cable, follow these steps:

1. Connect each cable or terminator block from the old Channel Interface Cable to the new one.
2. Ask the host computer operator to return the host computer or the channel to an operational state.
3. After completing the replacement process, return to the procedure that you were following.



## Routing the Adapter Cables through the Cable Guides

After you have completed all cable connections, secure the cables in the cable guides by following these steps for each 2216 base unit:

1. Release the existing plastic cable ties that hold the cables in the cable guide bracket.

### Notes:

- a. Do not attach any cable ties until you are finished routing all cables.
- b. When fastening optical fiber and other cables together using the same cable tie, be careful not to fasten the tie too tightly. Overtightening the ties can damage the optical fiber cable. Whenever possible, route optical fiber cables separately from wire-based cables.

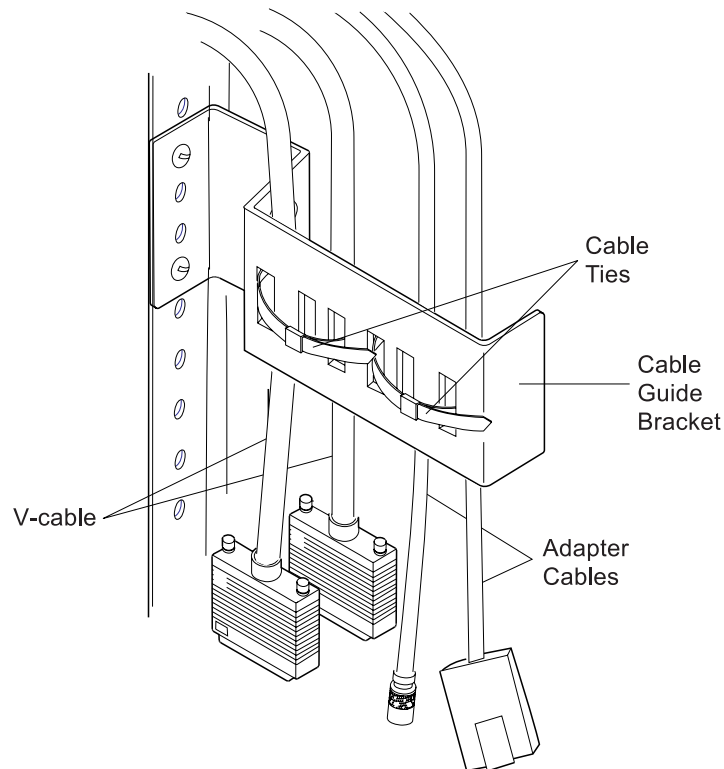

2. Remove the plastic cable strap from the cable guide arm.
3. Route all cables, and extender cables through the cable guide arm and bracket, giving the cables the same amount of slack.
4. Replace the plastic cable strap from the cable guide arm.
5. Retie the plastic cable ties to secure the cables.

You have completed cable routing.

## Releasing the Device to Your Customer

On Model 400, a quick reference card is located in the slot under the Model 400, enter the information about the adapter type and slot number for each Parallel Channel Adapter that is installed. Write on the worksheet the slot number for each Parallel Channel Adapter in the Model 400.

After you complete the card return it to the slot under the Model 400. Store the manuals in or near the rack.

If you have added or removed any hardware, the customer must reconfigure the application software.

You can now release the device to your customer.

## Chapter 5. Model 400 FRU Exchange

### Important

The system card and a power supply in a Model 400 with a single power supply are **not** hot pluggable. This means that you must switch off power to the system when replacing either of them. Other FRUs are hot pluggable and can be exchanged without powering OFF the Model 400, although the adapter or other FRUs must be reset before new configurations can take effect. Follow carefully the procedure described.

Before removing an adapter, be sure that the corresponding resource has been **disabled** by the operator at the operator console.

Each time you change a FRU, carefully record its location and check that the attached cables are correctly labeled and reconnected.

In Table 5-1, find the FRU you want to exchange and go to the procedure indicated.

Table 5-1. Model 400 FRU Exchange

FRU Name	Go to
Power supply	"Exchanging a Power Supply" on page 5-2
System card	"Exchanging the System Card" on page 5-3
Hard drive	"Exchanging the Hard Drive on the System Card" on page 5-6
DIMM	"Replacing the Memory on a System Card" on page 5-9 "Installing Memory Upgrades on a System Card" on page 5-11
Fan tray	"Exchanging the Fan Tray" on page 5-13
Adapter type xxx	"Exchanging an Adapter" on page 5-14
ISDN daughter card	"Exchanging the ISDN Daughter Card" on page 5-18
Backplane	"Exchanging the Backplane" on page 5-19
Operational code	"Installing Operational Software on the New Hard Drive" on page 5-8
Channel Adapter	"Installing and Removing Channel Adapters" on page 4-3

---

## Exchanging a Power Supply

**Attention:** A power supply is hot pluggable if an optional load-sharing power supply is also installed.

1. Switch off the power supply.
2. Unplug the power cord.
3. Remove the power supply by loosening the screws at the top and bottom and pulling the handle.

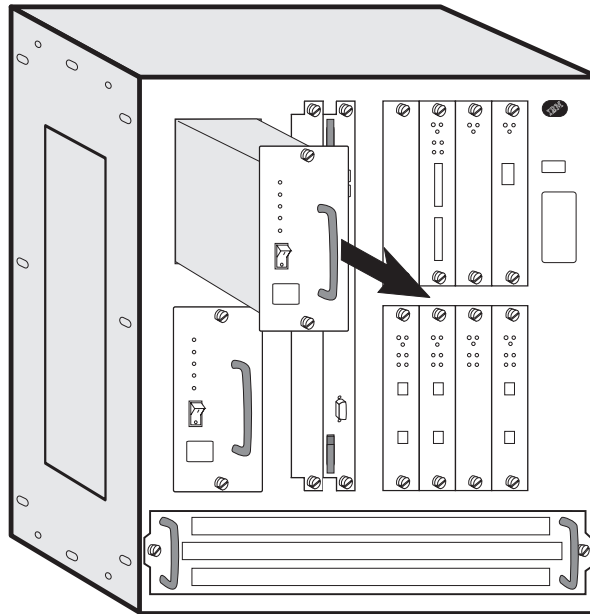

4. Install the new power supply. The power supply will slide into place on metal rails in the unit.
5. Attach the power cord.
6. Switch on the power.
7. Verify the LEDs. See “LED Indicators” on page 1-2.
8. Notify the network administrator that you are finished repairing the 2216.

---

## Exchanging the System Card

### Attention:

- The system card is *not* hot pluggable.
- You will remove and retain the hard file from the old system card. The hard file that comes with the new system card is *blank*.
- Make note of the part number of your system card.
  - First-generation FRU system cards (part number 85H7916 or 30L5820) support 64 MB (two non-replaceable 32-MB dual inline memory modules [DIMMs]) of memory
  - Second-generation FRU system cards (part number 85H9682 or 25L5177 or 25L4784) support up to 256-MB of total memory (up to two 64-MB DIMMs or two 128-MB DIMMs.)
  - The third-generation FRU system card (part number 30L7406) supports up to 512-MB of total memory

Next, the intent is to reuse the customer's memory on the replacement card.

- If you replace a first-generation FRU system card (part number 85H7916 or 30L5820) with a second- or third-generation FRU card, you need to upgrade the firmware to allow the use of the new memory DIMMs. See “Updating System Firmware” on page 8-14.
- If you replace a second- or third-generation FRU system card (that is, any system card *excluding* FRU PN 85H7916 or 30L5820), you need to move the customer's DIMMs from the defective card to the replacement card. If the replacement card already has one DIMM, remove that DIMM and place it on the defective card. The defective card should be returned. The replacement FRUs comes with zero or one DIMM installed.

1. Switch off each power supply.
2. Label the cables on the system card. Unplug the cables and the PCMCIA modem (or other PCMCIA cards).
3. Loosen thumbscrews on the system card.
4. Remove the defective system card.

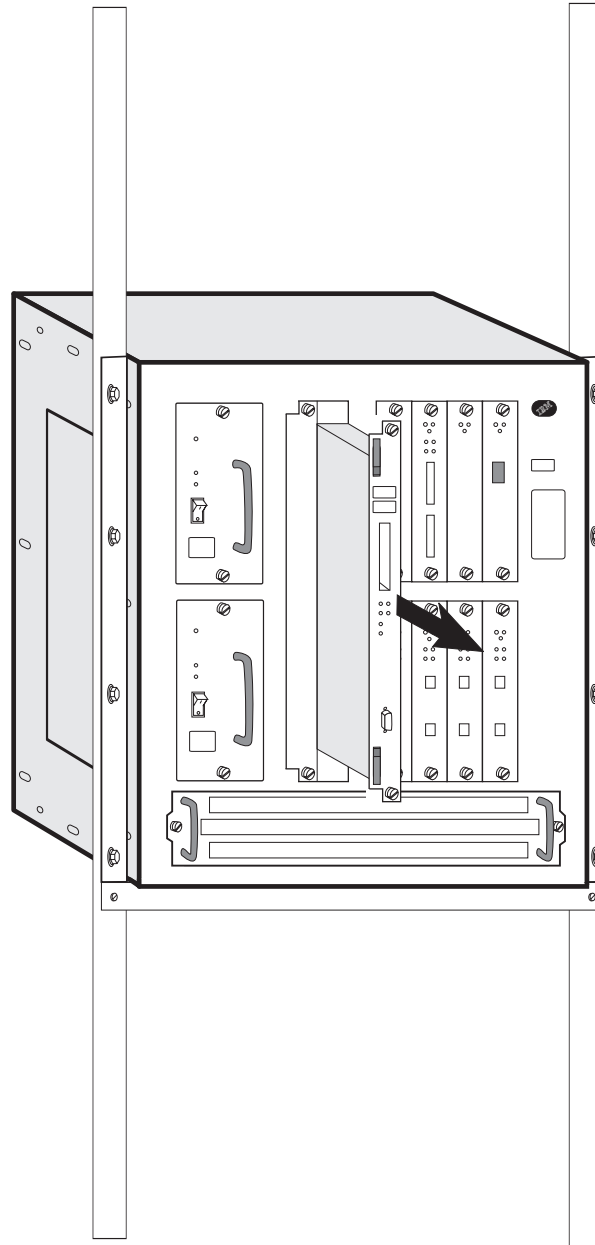

5. Remove the hard drive from the defective system card and install it on the replacement system card (see “Exchanging the Hard Drive on the System Card” on page 5-6). Return the hard drive that came with the replacement system card with the defective system card. The hard file that comes with the new system card is blank. If you are replacing a first-generation FRU system card, skip to step 7.
6. Move the customer's DIMMs from the defective card to the replacement card. If the replacement card already has one DIMM, remove that DIMM and place it on the defective card. The defective card should be returned.
7. Install the new system card. Make sure the tray on the system card is aligned with the plastic grooves and then carefully slide it in until it is supported by the box so that your hands are free for the next step.

While holding the locking latches so that they are perpendicular to the face of the system card, slide the card in until the locking latches engage. By pressing the locking latches in, you will cause the card to be drawn in until the face of the system card is flush with the face of the box.

8. Tighten the thumbscrews on the face of the adapter card clockwise.
9. Plug the cables into the system card.
10. Plug the PCMCIA modem into the new system card.
11. Power on and verify the LEDs. See "LED Indicators" on page 1-2.
12. Write the box serial number into the Vital Product Data on the new system card. Go into the firmware (see "Firmware Interface" on page F-1) and follow the procedures for using the Utilities option.
  - a. Under Utilities, select option 9 "View or Set Vital Product Data"
  - b. Select slot B
  - c. Select the "Hardware Vital Product Data" option
  - d. Type in the box serial number.
13. Notify the network administrator that you are finished repairing the 2216.

---

## Exchanging the Hard Drive on the System Card

1. Remove the system card as described in steps 1 through 4 in “Exchanging the System Card” on page 5-3.

**Attention:** In the following step, be sure to support the hard drive to avoid damaging the pins when the screws are removed.

2. Lay the system card on a soft non-conductive surface.
3. On the bottom of the system card, remove the four screws (with a screw starter) while holding the hard drive in place.

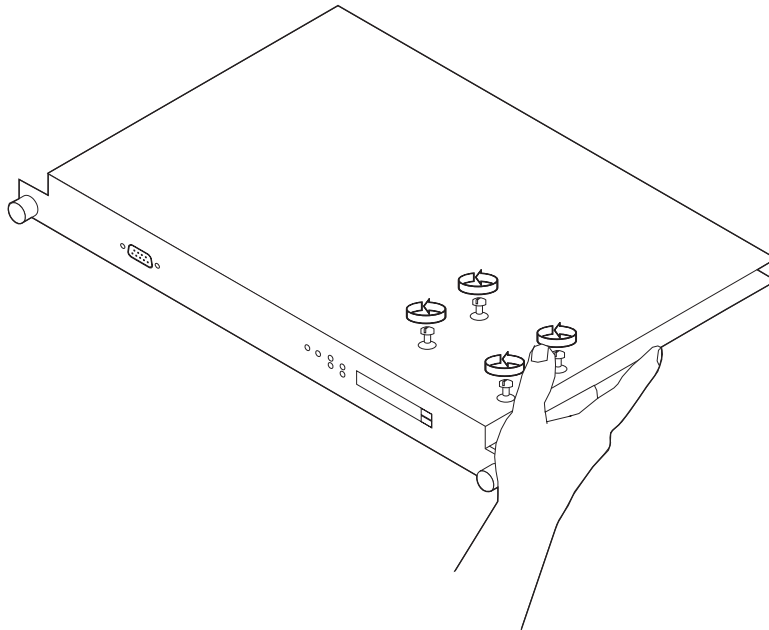

4. On the reverse side of the system card, disconnect the drive from the connector and lift it off the system card.

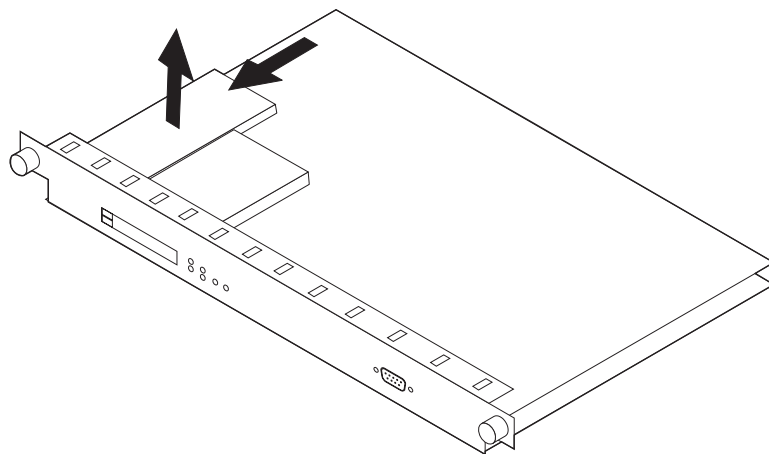

5. Center the new hard drive inside the lines on the system card.



**Note:** If you do not center the hard drive, the electrical pins on the hard drive will be visible next to the hard drive connector on the system card. Install the new hard drive by reversing steps 3 and 4 above. Be sure to support the hard drive while installing the screws.

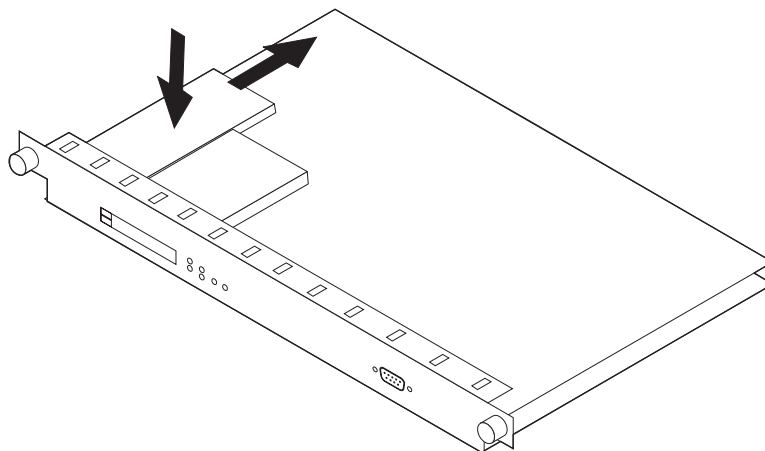

6. Reinstall the system card as described in “Exchanging the System Card” on page 5-3 at step 7.

---

## Installing Operational Software on the New Hard Drive

Use this procedure when you are replacing a defective hard drive.

**Note:** This procedure should be performed by trained IBM service personnel. Customers who need this done should contact IBM service.

Follow these steps to install the operational software on the hard drive:

1. Restart the IBM 2216 in Attended mode or press **F1** (possibly several times) during the load sequence from a console. (You can also access the firmware from the command line interface. See the chapter entitled "Accessing the Firmware from the Command Line Interface" in the *Multiprotocol Access Services Software User's Guide* for additional information.) This will bring up the firmware System Management Services menu.
2. Select **Utilities**.
3. From the menu, select **Prepare Hard Disk** and press **Enter**.
  - If no errors occur, continue with step 4.
  - If error code 30002000 occurs during format, proceed as follows:
    - a. From the System Management Services menu, select **Select Device to Test**
    - b. Select **Test IDE devices**
    - c. Press the **F4** key for Parm Setup
    - d. Select **Run Interactive Test and Stop on Error**
    - e. Press **F6** to begin the tests
      - Attention** The next step formats the hard disk and destroys all data on the hard disk
    - f. Select **Format IDE device**, and press **Enter**
    - g. Return to step 3.
4. Reload the firmware to the hard disk using Xmodem (see "Updating System Firmware" on page 8-14).
5. The hard drive is now prepared to receive operational software files.
6. Select **Utilities** from the System Management Services menu
7. Select **Change Management** (see "Change Management" on page 8-20).
8. Use Xmodem to transfer the complete set of operational software files from a workstation to the IBM 2216 hard drive (see step 10 on page F-10). You transfer the files to banks within the IBM 2216. These banks represent the directories that you have just created.
9. After you have successfully transferred the operational software, go through the configuration procedures to enable the new software (see "Performing Change Management Operations" in the *Multiprotocol Access Services Software User's Guide*).

## Replacing the Memory on a System Card

This procedure can be used for replacing faulty DIMM modules in your Model 400 on any system card *excluding* system card FRU PN 85H7916 or 30L5820.

There are slots for two DIMMs on the system card. If you install more than one DIMM, the second DIMM must be the same capacity as the first (that is, you can install two 64-MB, 128-MB, or 256-MB DIMMs.)

To replace faulty memory modules:

1. Identify the faulty memory module. See the following figure for the socket designations.
2. Remove the faulty DIMMs by pulling down the lever at the edge of the DIMM socket. (Use your thumbnail or a small non-metallic device to gently move the spring latch away from the end of the DIMM.) The DIMM will automatically be pushed partially out of the slot.

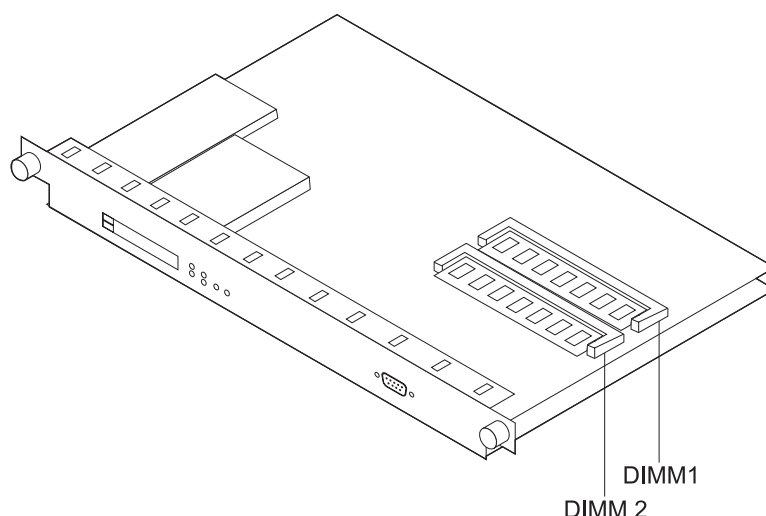

Figure 5-1. DIMM Socket Designations

3. Gently slide the DIMM module out of its connector socket.
4. Remove the antistatic bag containing the replacement DIMM from its shipping container.

**Attention:**

Electrostatic discharge (ESD) can damage the static-sensitive devices on circuit boards. To avoid this kind of damage, use the following precautions:

- Do not remove the DIMM until you are ready to insert it into the 2216.
  - Use correct grounding techniques when inspecting and installing the DIMM. Use a foot strap or grounding mat, or wear a grounded static discharge wrist strap, or touch a grounded rack or other source of ground before you handle the DIMM.
5. Remove the DIMM from the antistatic bag. Inspect it for damage. Always handle the DIMM by the ends (preferably grasp it between the middle finger and thumb; do not touch the components). If the DIMM appears to be damaged, return it to the antistatic bag and contact the supplier.
  6. Insert the new DIMM into the appropriate slot. (Grasping the DIMM between the middle finger and thumb, place it connector edge down into the DIMM socket. Applying slight pressure to the top edge of the DIMM, move it forward until it is correctly aligned and snaps in place.)

The lever will snap back into place as the DIMM is fully inserted.

## Model 400

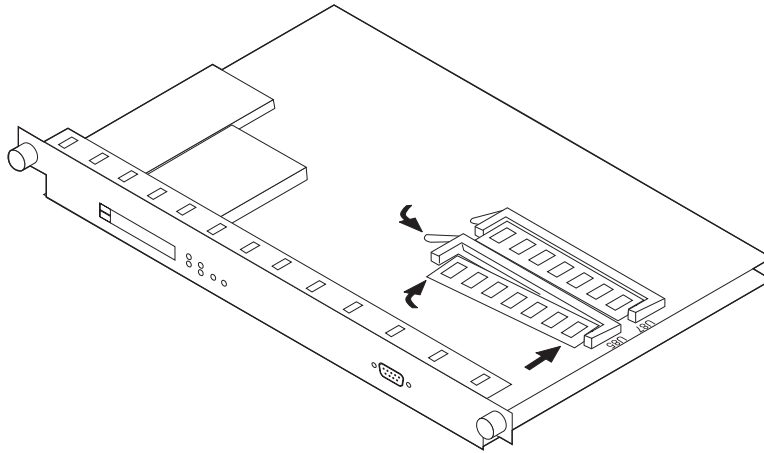

7. If your only task was to remove and replace a DIMM, you are ready to reinstall the system card. Go to “Exchanging the System Card” on page 5-3 at step 7.

## Installing Memory Upgrades on a System Card

This procedure can be used for installing memory upgrades to your Model 400 on any system card *excluding* system card FRU PN 85H7916 or 30L5820.

There are slots for two DIMMs on the system card. If you install more than one DIMM, the second DIMM must be the same capacity as the first (that is, you can install two 64-MB, 128-MB, or 256-MB DIMMs.)

1. Using the instructions included in the Memory Update Kit, identify any DIMMs that are to be removed. See the following figure for the socket designations.
2. Remove those DIMMs by pulling down the lever at the edge of the DIMM socket. (Use your thumbnail or a small non-metallic device to gently move the spring latch away from the end of the DIMM.) The DIMM will automatically be pushed partially out of the slot.

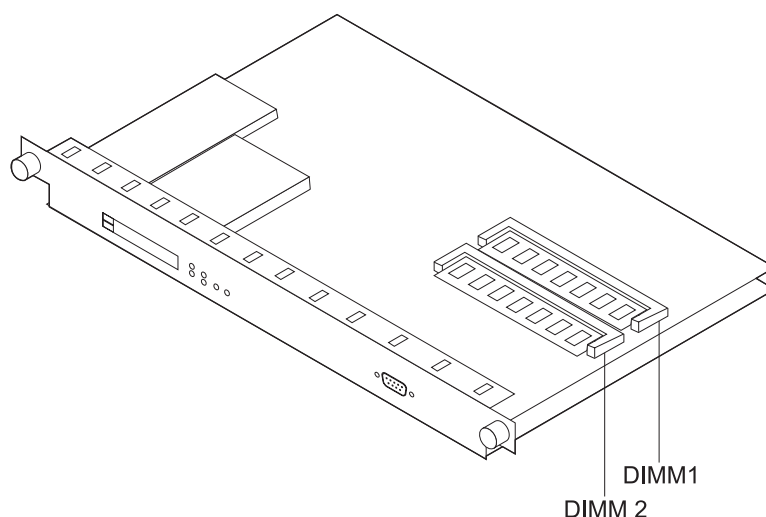

3. Gently slide the DIMM module out of its connector socket.
4. Remove the antistatic bag containing new DIMMs from its shipping container.

**Attention:**

Electrostatic discharge (ESD) can damage the static-sensitive devices on circuit boards. To avoid this kind of damage, use the following precautions:

- Do not remove the DIMM until you are ready to insert it into the 2216.
  - Use correct grounding techniques when inspecting and installing the DIMM. Use a foot strap or grounding mat, or wear a grounded static discharge wrist strap, or touch a grounded rack or other source of ground before you handle the DIMM.
5. Remove the DIMM from the antistatic bag. Inspect it for damage. Always handle the DIMM by the ends (preferably grasp it between the middle finger and thumb; do not touch the components). If the DIMM appears to be damaged, return it to the antistatic bag and contact the supplier.
  6. Insert the new DIMM into the appropriate slot, according to the instructions included in the Memory Update Kit. (Grasping the DIMM between the middle finger and thumb, place it connector edge down into the DIMM socket. Applying slight pressure to the top edge of the DIMM, move it forward until it is correctly aligned and snaps in place.)

The lever will snap back into place as the DIMM is fully inserted.

## Model 400

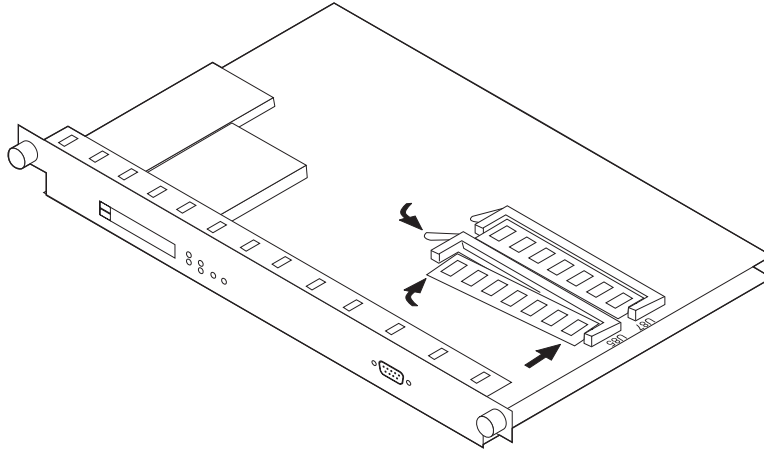

7. If your only task was to initially install a new DIMM, you are ready to reinstall the system card. Go to “Exchanging the System Card” on page 5-3 at step 7.

## Exchanging the Fan Tray

**Attention:** The fan tray *is not* hot pluggable on Model 400s that have a first-generation system card (PN number 85H7916 or 30L5820). You must shut down the 2216 completely before replacing the fan tray. If the fan tray is removed, or if two or more fans fail, the box may shut down.

The fan tray *is* hot pluggable on Model 400s that do not have the first-generation system card (PN number 85H7916 or 30L5820); however, you must install the new tray within **3 minutes** of removing the defective tray to prevent overheating the Model 400.

1. Loosen the two thumbscrews that secure the fan tray and remove the fan tray.

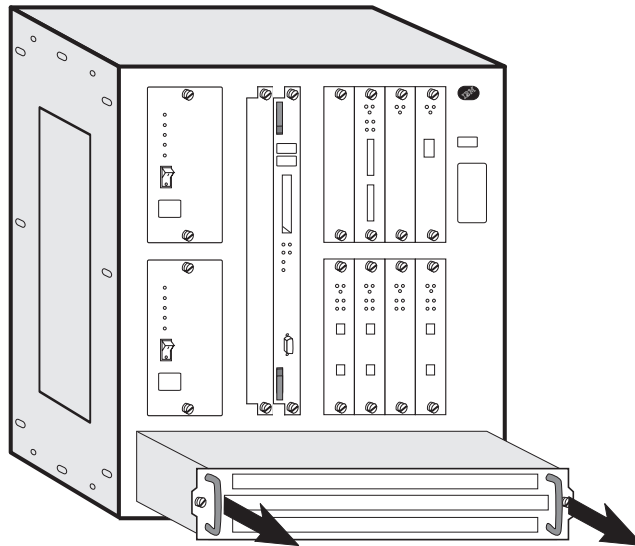

2. Slide the new fan tray in until the tabs on the back of the fan tray are in the slots. This aligns the connectors with the plugs.

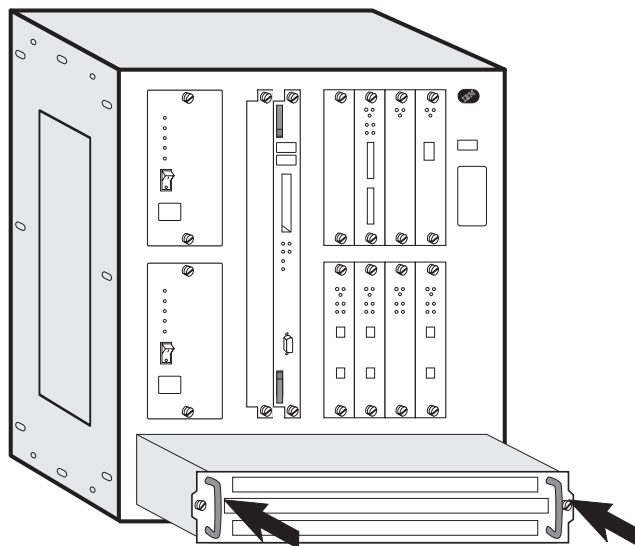

3. When the fan tray is flush with the box, tighten the two thumbscrews.

---

## Exchanging an Adapter

**Note:** The adapter you replace must be of the same type as the original. Otherwise, you will need to reconfigure. See the *2216 Introduction and Planning Guide* and the *Multiprotocol Access Services Software User's Guide*.

1. Locate the adapter that is to be replaced.

2. **Attention:**

- Adapters are hot pluggable, but you must disable all adapter ports on the adapter that you are removing before you remove cables. See “Suspending Traffic on an Adapter Port” on page F-7.
- If an adapter is removed prior to disabling the ports, a machine check can occur and the 2216 may become idle.

3. Label the cables for correct reconnection.

4.

- If you are removing a serial adapter (EIA 232E/V.24, V.35/V.36, X.21, which are LICs 282, 290 and 291), you need to disable the WAN Reroute process before you remove the adapter. (See “Disabling Interfaces that Have WAN Reroute Enabled” on page F-9.)
- If you are removing a Parallel Channel Adapter (LIC 299), perform the steps in “Removing Channel Adapters” on page 4-13 beginning with step 1 on page 4-13. (This requires a channel-trained service person.)

5. Loosen the screws (if present) that secure the cable or cables.

6. Remove the cable or cables.

7. **Attention:** You must turn the adapter's thumbscrews simultaneously when unseating or seating the adapter during removal or installation. By doing so, you prevent stripping the thumbscrews. If you strip the thumbscrews, you may not be able to seat or reseal the adapter correctly.

Loosen the thumbscrews on the adapter.



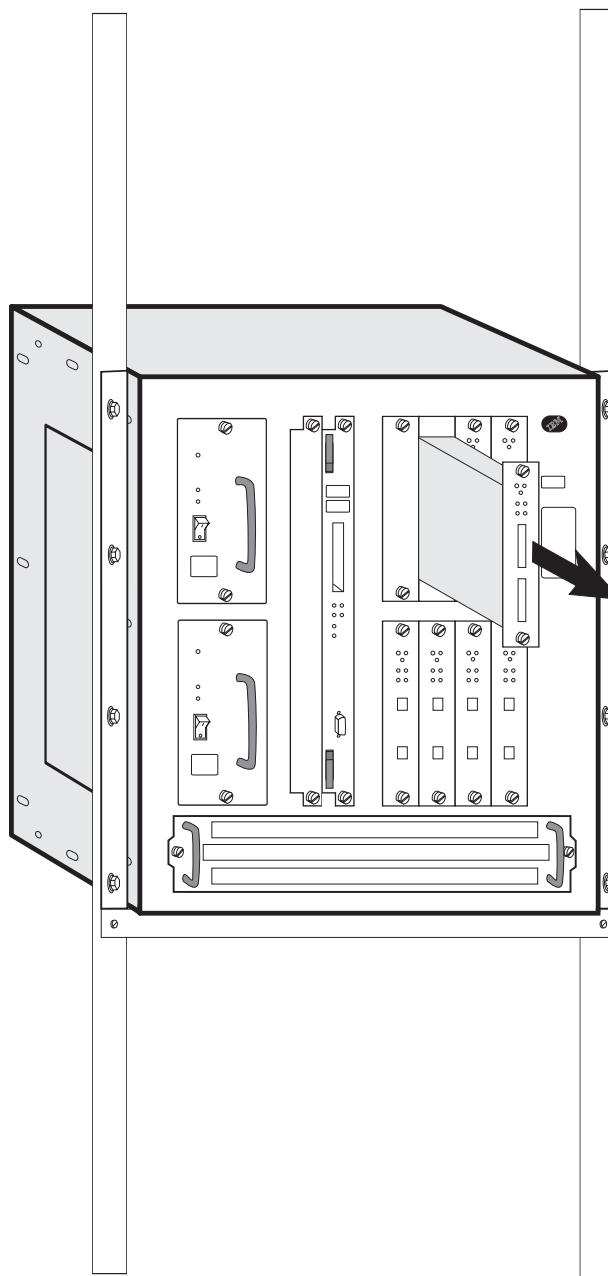

8. Remove the adapter from its location.

If you are replacing LIC 297 or 298 (4-port ISDN PRI/Channelized adapter), remove the daughter cards from the old adapter and put them onto the new adapter (see “Exchanging the ISDN Daughter Card” on page 5-18)

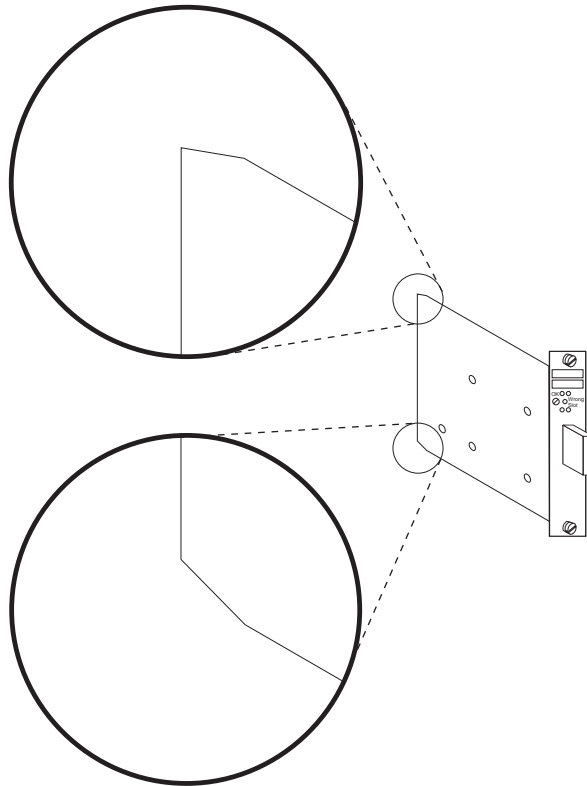

9. Install the new adapter. Notice the notches at the adapter card's angled corners and position them on the left as illustrated.

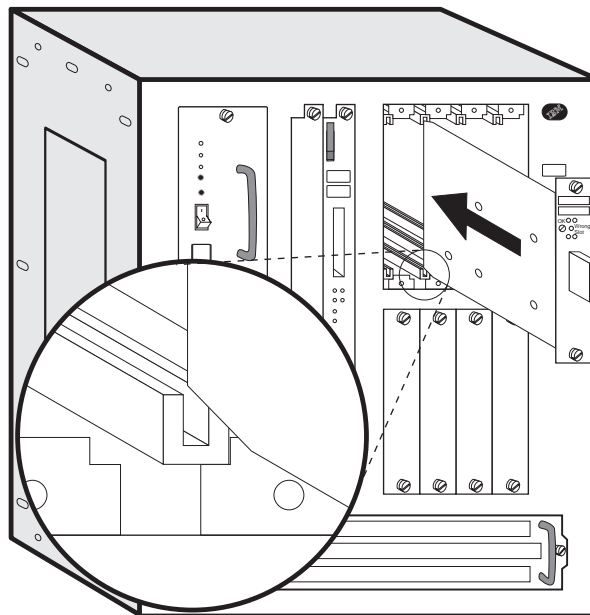

10. Carefully position the notches of the adapter card in the appropriate adapter slot's upper and lower rails. Then, guide the adapter forward on the rails as pictured.
11. Make sure the adapter card is aligned with the plastic grooves and then slide it in until the thumbscrews contact the frame.

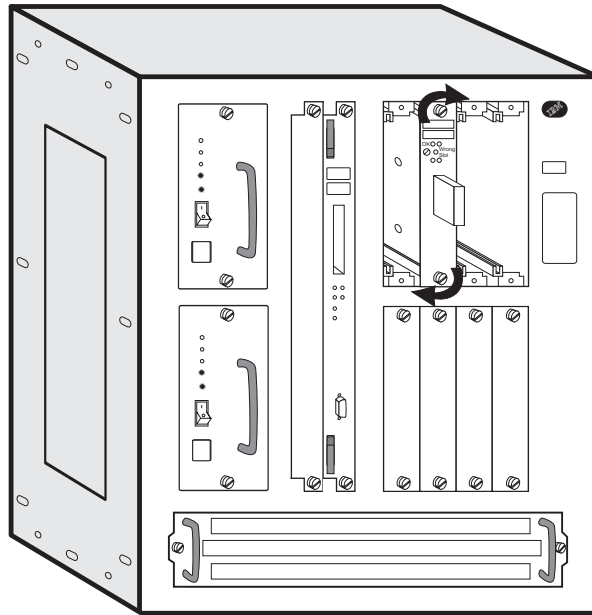

When the card makes full contact with the rear of the IBM 2216, press and simultaneously turn each thumbscrew on the face of the adapter card clockwise, **only** until the adapter is firmly seated.

12. Secure the module by tightening the screws.
13. Check that the green LED of the adapter comes ON and that the Wrong Slot LED is OFF. If not, check the adapter installation. If the problem persists call the support center. Otherwise, continue.
14.
  - If you are replacing/inserting a serial adapter (EIA 232E/V.24, V.35/V.36, X.21, which are LICs 282, 290 and 291) and you went through the WAN Reroute disable procedure (“Disabling Interfaces that Have WAN Reroute Enabled” on page F-9), you need to enable the WAN Reroute process. (See “Enabling WAN Reroute after You Have Disabled it” on page F-9).
  - If you are replacing a Parallel Channel Adapter, perform the steps in “Installing Channel Adapters” on page 4-10 beginning with step 1.
15. Replace the removed cable or cables, then tighten the cable screws (if present).
16. Re-enable all adapter ports. See “Resuming Traffic on an Adapter Port” on page F-7.

---

## Exchanging the ISDN Daughter Card

1. Remove the adapter. (See “Exchanging an Adapter” on page 5-14. Perform all steps through step 8 on page 5-15.)
2. Follow these steps to remove the faulty daughter card:
  - a. Lay the adapter (metal side down) on a flat surface.
  - b. Remove (and keep) the four screws that attach the daughter card to the adapter.
  - c. Disconnect the daughter card from the adapter connector by gently pulling the daughter card up about an inch from the adapter

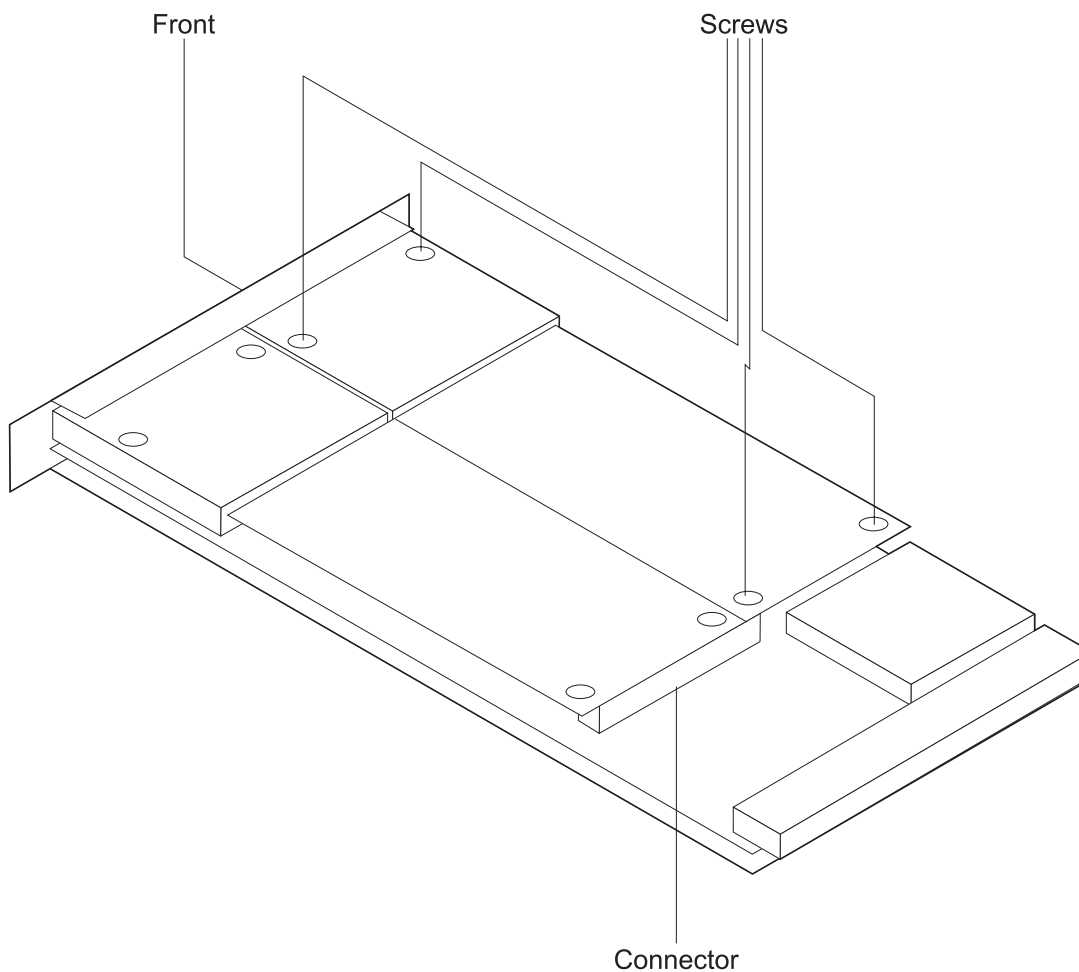

- d. While raising both ends of the daughter card, slide the daughter card to the side to remove the card.
3. Follow these steps to install the daughter card:
  - a. With the large white label facing up, slide the end of daughter card into the rectangular opening on the front panel.
  - b. Gently push on the card near the two holes in the corners of the card to secure the connector
  - c. Install the two short screws into the corners of the card.
  - d. Install the two longer screws into the holes that are near the black cover on the card.
4. Install the adapter. (Use the steps beginning at step 9 on page 5-16).

## Exchanging the Backplane

**Note:** If the Model 400 is rack-mounted, this procedure requires two people to remove and install the Model 400 in the rack.

1. Switch off each power supply.
2. Unplug the power cord from the power receptacle.
3. Label the cables with the adapters and ports they plug into. Unplug all the cables.
4. Make a note of the slot position of each card in the unit. If you have a filled-out *Hardware Configuration Quick Reference* card, this information should be already available. This card should be in the area on the underside of the Model 400 on the left.

5. **CAUTION:**

**A fully populated IBM 2216 Model 400 weighs about 43.1 kg (95 lb).**

**Note:** For translations of this safety notice, see Appendix H, "Safety Information" on page H-1.

If the Model 400 is rack-mounted continue with step 6; otherwise, go to step 11 on page 5-20.

6. Remove the:
  - Power supplies (loosen the screws on each component and pull the handle).
  - System card (see "Exchanging the System Card" on page 5-3).
  - Adapters (see "Exchanging an Adapter" on page 5-14).
  - Fan tray (see "Exchanging the Fan Tray" on page 5-13).

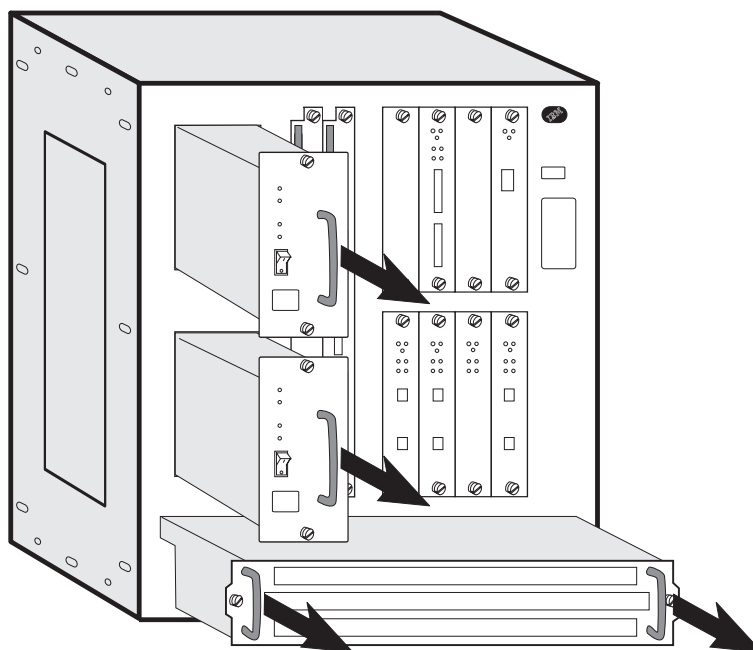

7. If the Model 400 is installed in a rack, but not on a shelf, it is recommended that you install a shelf or the installation aid under the Model 400 before removing the screws from the rack-mounting brackets.
8. Remove the screws from the rack-mounting brackets.

## Model 400

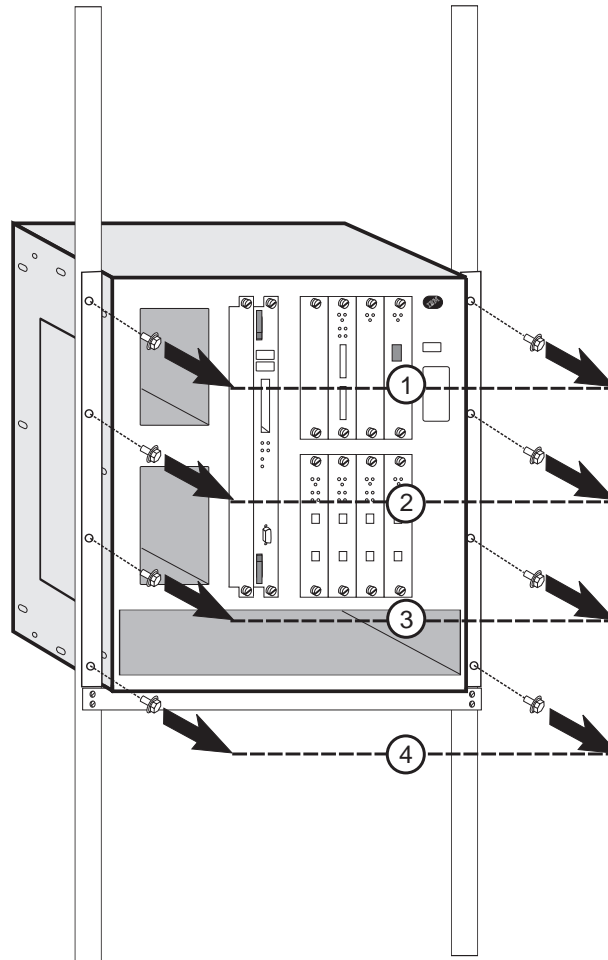

9. Hold the Model 400 from the top of the back and bottom of the front, and then slide it forward out of the rack.
10. Place the Model 400 on a table.
11. Remove the three screws near the top of the side panels.

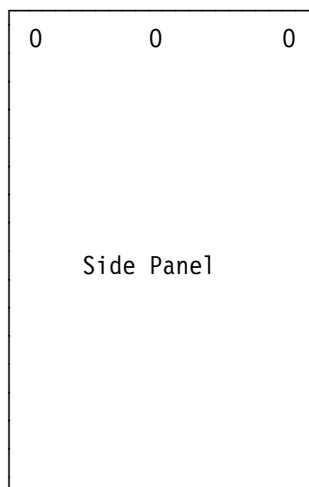

12. Remove the top panel. To do this, go to the rear of the Model 400. Lift the top panel, and then slide the panel toward you.

- On each side of the Model 400, remove the three screws along the rear of the side panels of the Model 400 that hold the backplane in place.

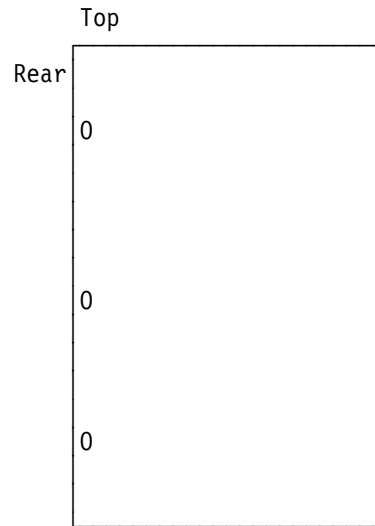

- Remove the eight nuts and star washers located on the inside of the Model 400.

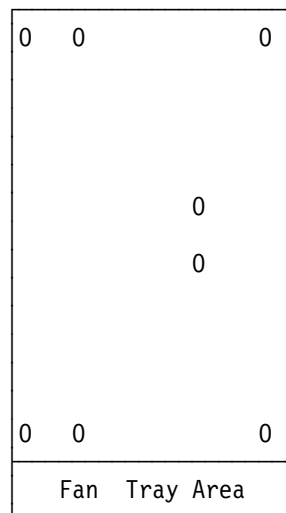

Relative locations of the nuts viewed from the front of the box

- Hold the backplane by the finger holes and lift it straight out of the Model 400.

## Model 400

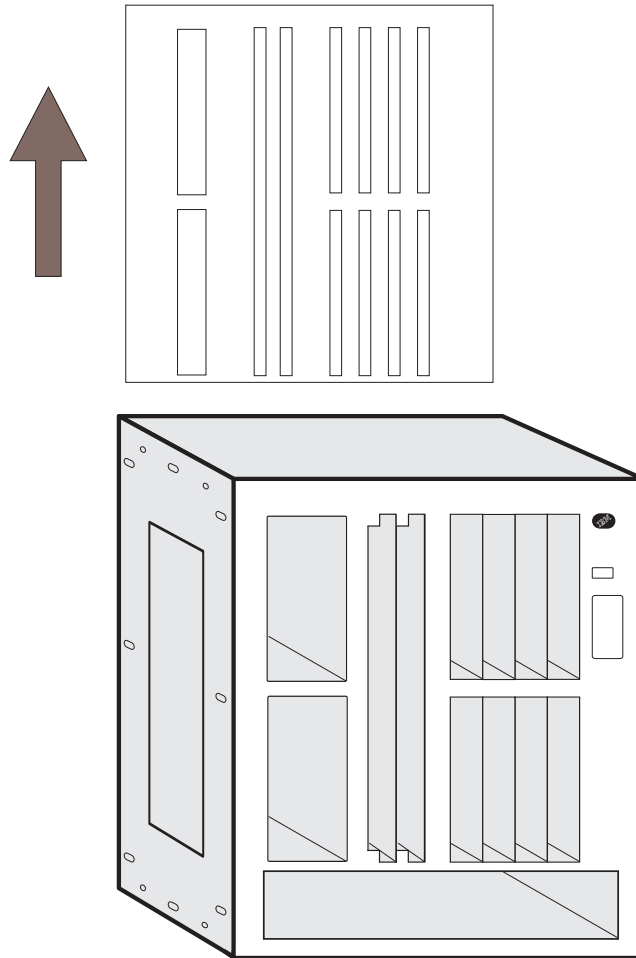

16. Hold the new backplane by the finger holes and lower it gently into the Model 400.
17. Align the screw holes on the backplane with those on the sides of the box.
18. Loosely install the top two screws on each side of the Model 400.
19. Reach inside the Model 400, grasp the bottom middle of the backplane's plastic shield, and press it up and toward you until all the bulkhead screws protrude through the chassis.
20. Loosely insert the remaining screws on each side.
21. Install and tighten the eight nuts and star washers inside the Model 400 that secure the backplane to the system.
22. Tighten the screws along the side of the box that hold the backplane in place.
23. Replace the top of the unit.
  - a. Align the five tabs on the top panel with the slots on the top front of the Model 400.
  - b. Lower the top, and then press it back into place.
  - c. Reinstall the middle screw on each side.
24. Reinstall and tighten the three screws that secure the top of the box to each side of the box.
25. Mount the Model 400 in the rack. It is recommended that you use a screw starter here.
  - a. If you have a shelf, install it in the rack first. Otherwise, install the installation aid.



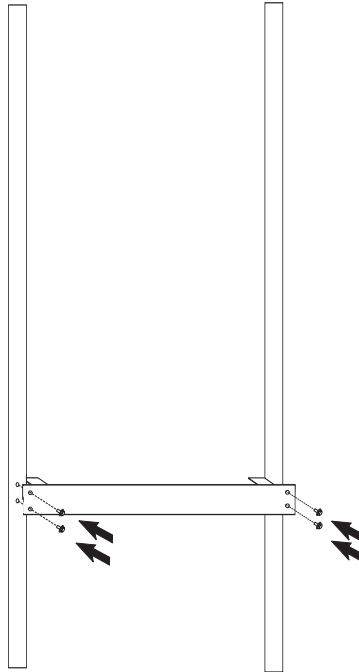

- b. Slide the Model 400 into the rack.
- c. While one person holds the box in place, the other should install the bottom screw into each mounting bracket. Then install the remaining six screws.

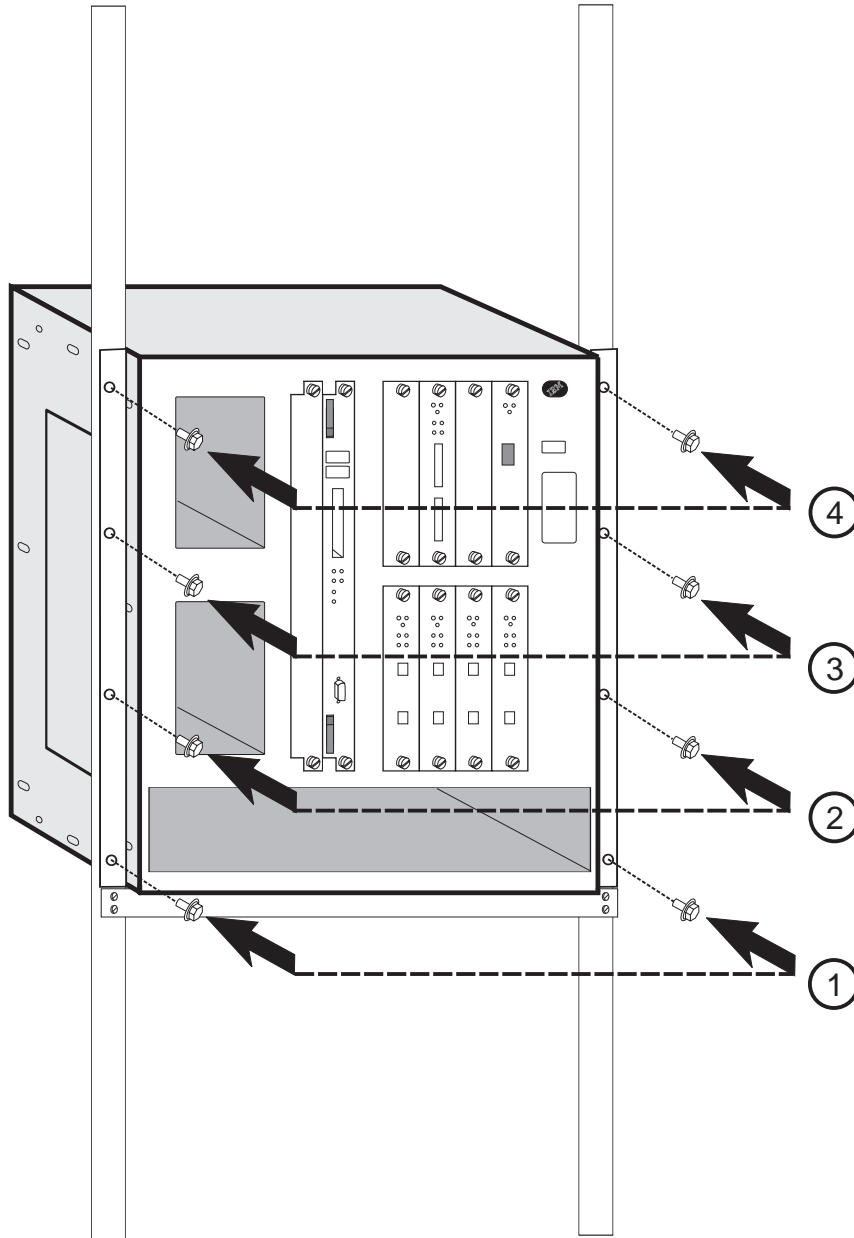

d. Remove the shelf, if necessary.

26. Install the fan tray. Slide the fan tray in until the tabs on the back of the fan tray are in the slots. This aligns the connectors with the plugs. When the fan tray is flush with the box, tighten the two screws.

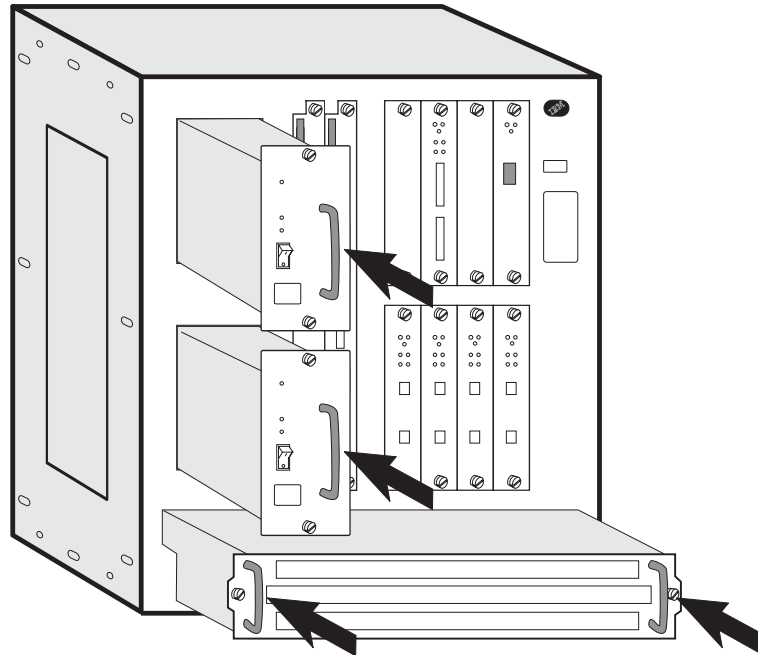

27. Install the slot cover into slot A.
28. Install the system card in slot B. Make sure the card is aligned with the plastic grooves and then slide it in until it is flush with the box. (See "Exchanging the System Card" on page 5-3 for details). Tighten the screws.
29. Moving from left to right, install the remaining adapters. Slide each adapter along the plastic grooves until it clicks into place. (See "Exchanging an Adapter" on page 5-14 for details.)
30. Finally, install the power supplies. The power supplies will slide into place by following metal rails in the box.
31. Connect the cables and power cord to the power receptacle.
32. Switch on the power.
33. Verify the LEDs. See "LED Indicators" on page 1-2
34. Notify the network administrator that you are finished repairing the 2216.



## Chapter 6. Model TX1 or TN1 FRU Exchange

### Important

Only the adapters of the Model TX1 or TN1 are hot pluggable, though you must disable all adapter ports on the adapter that you are removing before you remove cables. You must also reset a replaced adapter before new configurations can take effect. The system card, power and fan assemblies, of the Model TX1 or TN1 are **not** hot pluggable. This means that you must disconnect power to the model TX1 or TN1 when replacing them. Follow carefully the procedure described.

Before removing an adapter, be sure that the corresponding resource has been **disabled** by the operator at the operator console.

Each time you change an adapter, carefully record its location and check that the attached cables are correctly labeled and reconnected.

In Table 6-1, find the FRU you want to exchange and go to the procedure indicated.

Table 6-1. Model TX1 or TN1 FRU Exchange

FRU Name	Go to
Power assembly	"Exchanging the Power Assembly" on page 6-2
System card	"Exchanging the System Card" on page 6-5
Hard drive	"Exchanging the Hard Drive on the System Card" on page 6-7
DIMM	"Replacing the Memory on a System Card" on page 6-9 "Installing Memory Upgrades on a System Card" on page 6-11
Fan	"Exchanging a Fan" on page 6-13
Adapter type xxx	"Exchanging an Adapter" on page 6-15
Backplane	"Exchanging the Backplane" on page 6-18
Operational code	"Installing Operational Software on the New Hard Drive" on page 5-8
Channel Adapter	"Installing and Removing Channel Adapters" on page 4-3

---

## Exchanging the Power Assembly

**Attention:** The power assembly is *not* hot pluggable on the Model TX1 or TN1.

1. Unplug the power cord from the outlet.
2. If the Model TX1 or TN1 is installed in a rack, remove it from the rack and place it on a table.
3. Remove the three screws securing the top cover. (If the rack-mounting brackets are on the unit, they will be removed when you remove the screws.)
4. Remove the top cover.

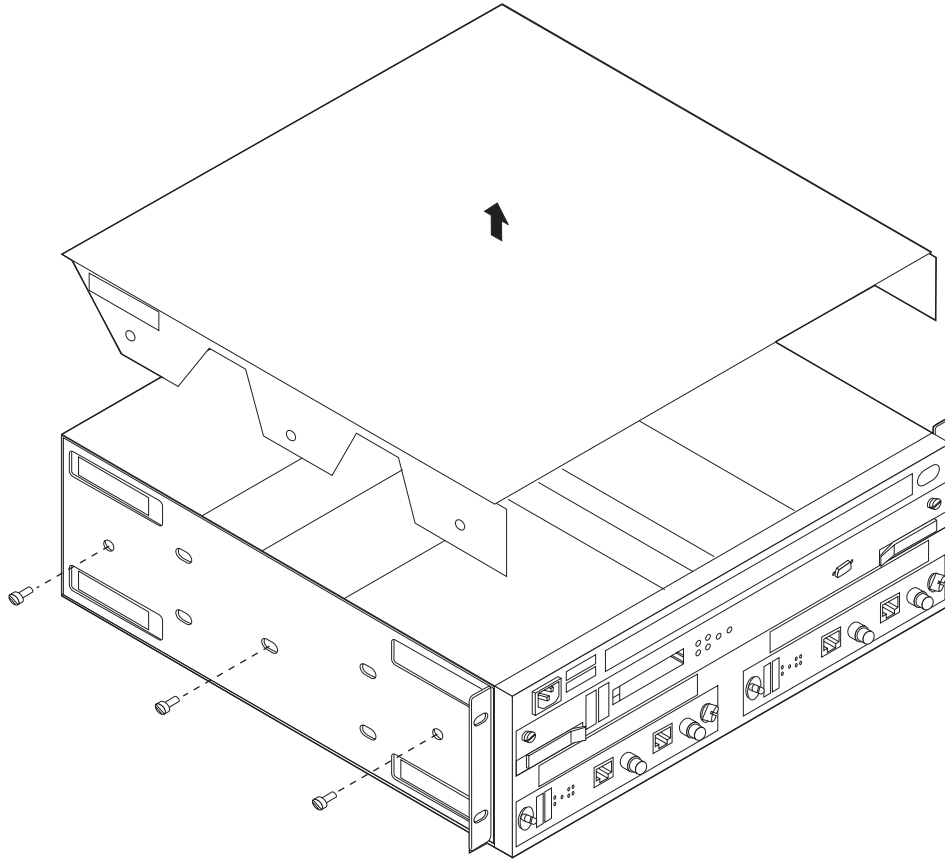

5. Locate the power assembly at the left rear of the unit.
6. Disconnect both cables on the right side of the power assembly.

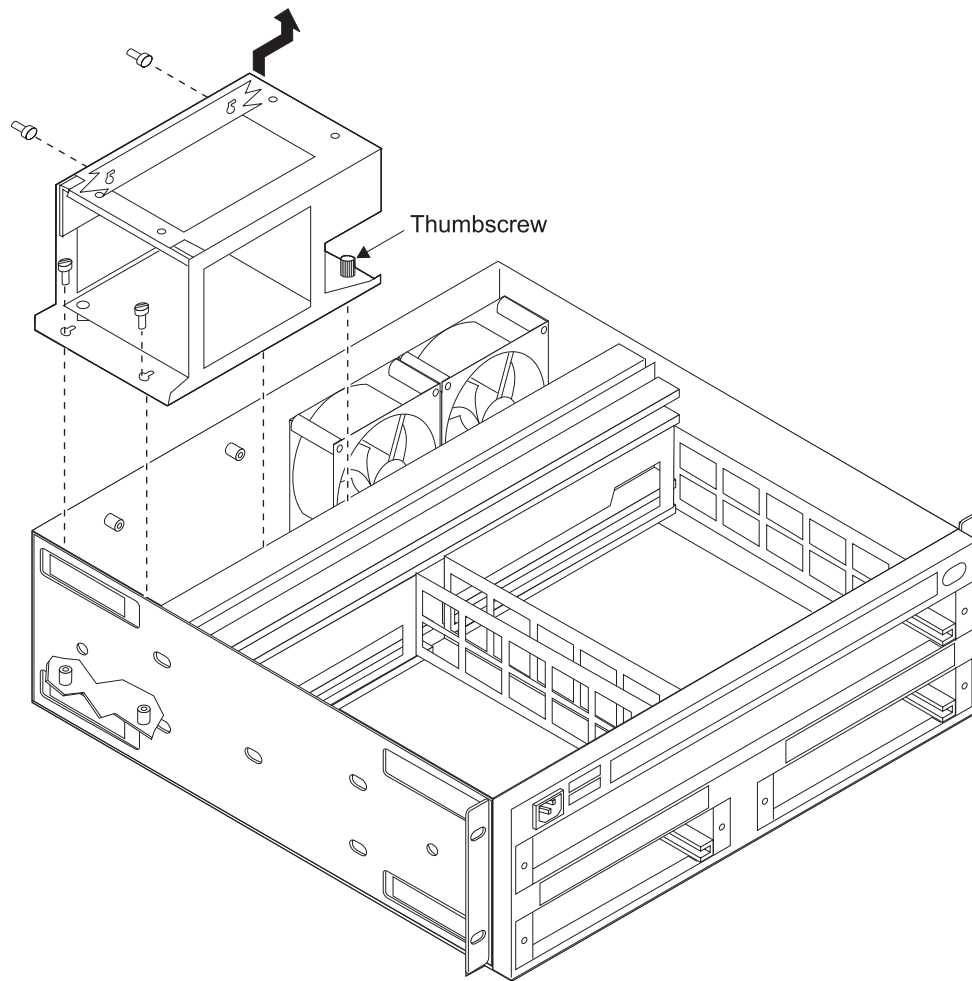

7. On the right side of the power assembly, loosen completely each of two thumbscrews that secure the power assembly to the bottom of the frame.
 

**Note:** As shown in the figure, the power assembly is attached to the frame by 4 pins.
8. Lift the right side slightly, and slide the power assembly to the right to disconnect it from the pins at the four locking slots (two each at the rear and bottom).
9. Disconnect the 2 primary power cable connectors from the left side of power assembly. Note the orientation of each of the connectors.
10. Raise and remove the power assembly.
 

To install the new power assembly, reverse the procedure. (Continue with the next step.)
11. Connect the 2 primary power cable connectors to the left side of the power assembly.
12. Place the power assembly locking slots onto both pins on the *rear wall* and above both pins on the *base*. Then, pressing down, slide the power assembly to the left rear of the unit, locking the assembly in place.
13. Tighten the thumbscrews on the power assembly.
14. Connect both cable connectors to the right side of the power assembly that connect power to the backplane.
15. Replace the top cover. (If you are installing the rack-mounting brackets onto the side of the unit, install the bracket that is labeled A onto the right side of the unit.)

## **Model TX1 or TN1**

16. Return the model TX1 or TN1 to its final rack or table location.
17. Attach the power cord.
18. Verify the system LEDs. See “LED Indicators” on page 2-2.
19. Notify the network administrator that you are finished repairing the Model TX1 or TN1.



## Exchanging the System Card

### Attention:

- The system card is **not** hot pluggable.
- You will remove and retain the hard drive from the old system card. The hard drive that comes with the new system card is **blank**.
- The Network Utility system card supports two 128-MB DIMMs or two 256-MB DIMMs.  
You will remove the DIMMs from the customer's card and install it onto the replacement System Card.

1. Unplug the power cord.
2. Label the cables on the system card. Unplug the cables and the PCMCIA modem (or other PCMCIA LAN cards).
3. Loosen thumbscrews on the system card.
4. Remove the defective system card by toggling the latches that are near the ends of the card.

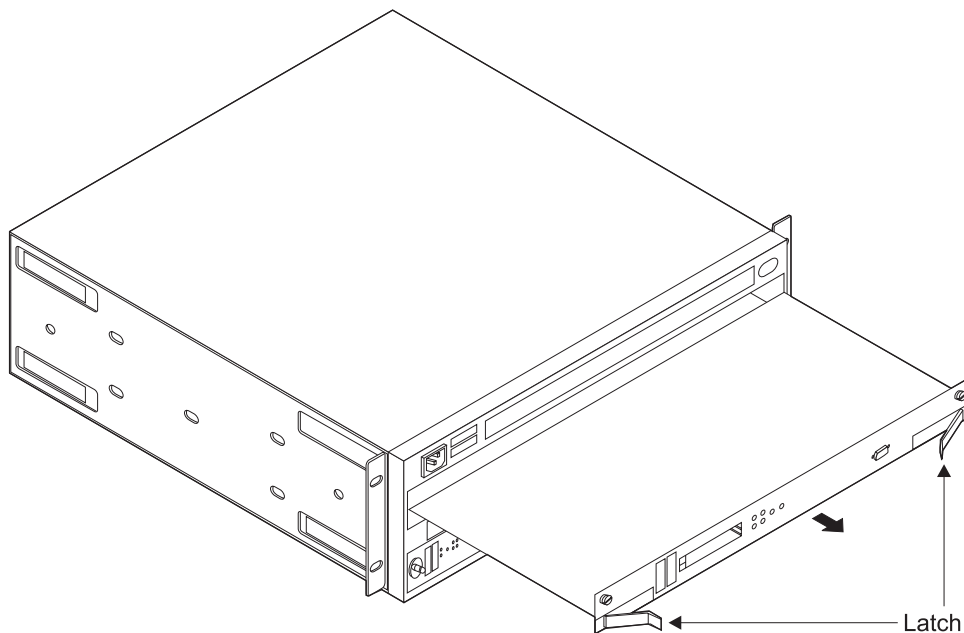

5. Remove the hard drive from the defective system card and install it on the replacement system card (see "Exchanging the Hard Drive on the System Card" on page 6-7). Return the hard drive that came with the new system card with the defective system card. The hard drive that comes with the new system card is blank.
6. Remove the DIMMs from the faulty system card (see "Replacing the Memory on a System Card" on page 6-9). Put the DIMMs onto the new system card.
7. Install the new system card. Make sure the tray on the system card is aligned with the plastic grooves and then carefully slide it in until it is supported by the box so that your hands are free for the next step.

While holding the locking latches so that they are perpendicular to the face of the system card, slide the card in until the locking latches engage. By pressing the locking latches in, you will cause the card to be drawn in until the face of the system card is flush with the face of the box.

## Model TX1 or TN1

8. Tighten the thumbscrews on the face of the card clockwise.
9. Plug the cables into the system card.
10. Plug the PCMCIA modem (or PCMCIA LAN Card) into the new system card.
11. Connect the system to a working power outlet and verify the LEDs. See "LED Indicators" on page 2-2.
12. Write the box serial number into the Vital Product Data on the new system card. Go into the firmware (see "Firmware Interface" on page F-1) and follow the procedures for using the Utilities option.
  - a. Under Utilities, select option 9 "View or Set Vital Product Data"
  - b. Select the "Hardware Vital Product Data" option
  - c. Type in the box's serial number.
  - d. Enter TX1 or TN1 for the model number in place of the 000. (The new system card defaults to 2216-000.)
13. Notify the network administrator that you are finished repairing the Model TX1 or TN1.

## Exchanging the Hard Drive on the System Card

1. Remove the system card as described in steps 1 through 4 in “Exchanging the System Card” on page 6-5.

**Attention:** In the following step, be sure to support the hard drive to avoid damaging the pins when the screws are removed.

2. Lay the system card on a soft non-conductive surface.
3. On the bottom of the system card, remove the four screws (with a screw starter) while holding the hard drive in place.

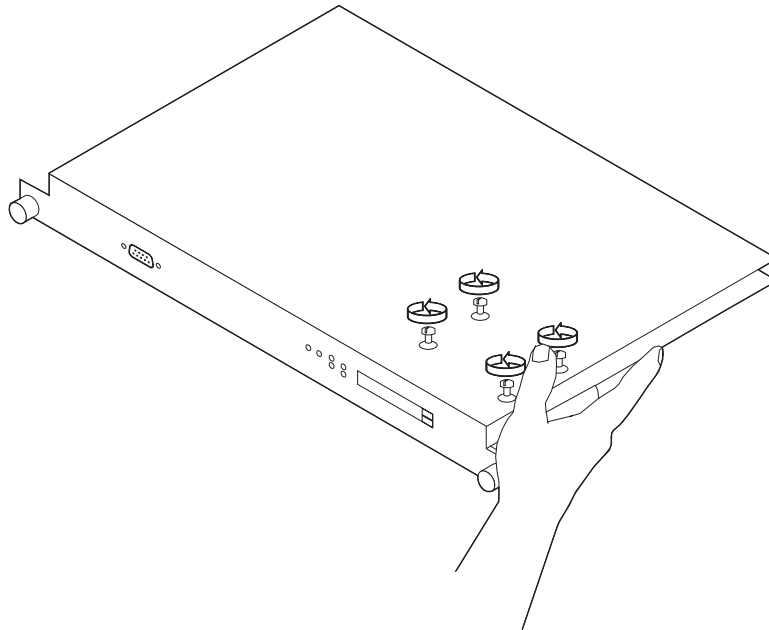

4. On the reverse side of the system card, disconnect the drive from the connector and lift it off the system card.

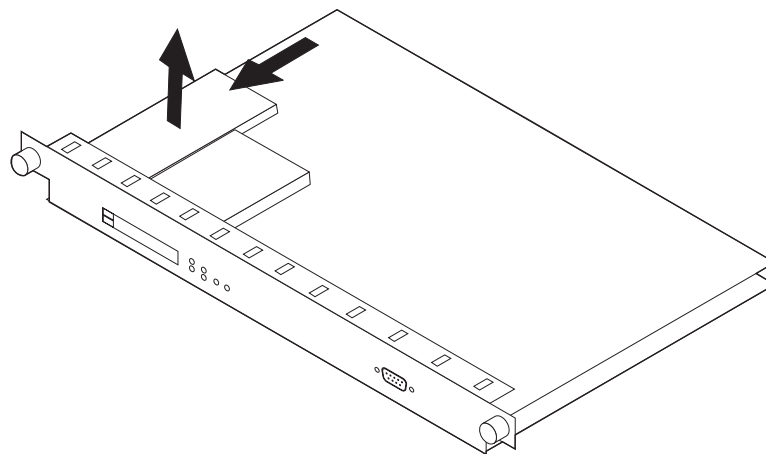

5. Center the new hard drive inside the lines on the system card.

## Model TX1 or TN1

**Note:** If you do not center the hard drive, the electrical pins on the hard drive will be visible next to the hard drive connector on the system card. Install the new hard drive by reversing steps 3 and 4 above. Be sure to support the hard drive while installing the screws.

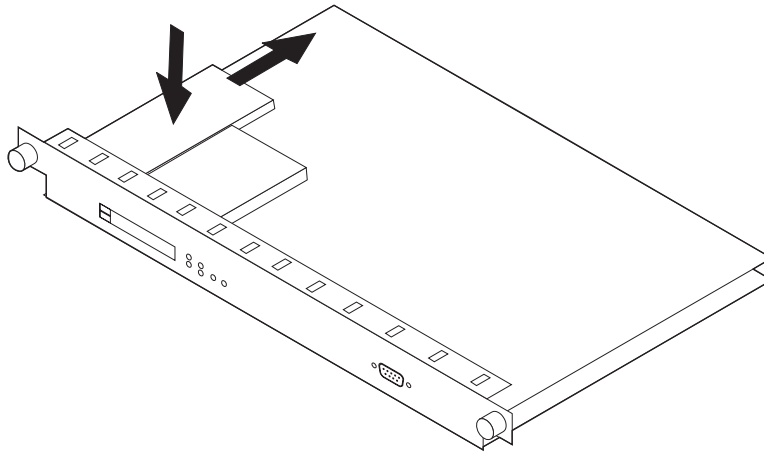

6. Reinstall the system card as described in “Exchanging the System Card” on page 6-5 at step 7.

## Replacing the Memory on a System Card

Use this procedure to replace faulty DIMM modules in your Model TX1 or TN1. To install a memory upgrade, see “Installing Memory Upgrades on a System Card” on page 6-11.

There are slots for two DIMMs on the system card. If you install more than one DIMM, the second DIMM must be the same capacity as the first (that is, you can install two 64-MB, 128-MB, or 256-MB DIMMs.)

To replace faulty memory modules:

1. Identify the faulty memory module. See the following figure for the socket designations.
2. Remove the faulty DIMMs by pulling down the lever at the edge of the DIMM socket. (Use your thumbnail or a small non-metallic device to gently move the spring latch away from the end of the DIMM.) The DIMM will automatically be pushed partially out of the slot.

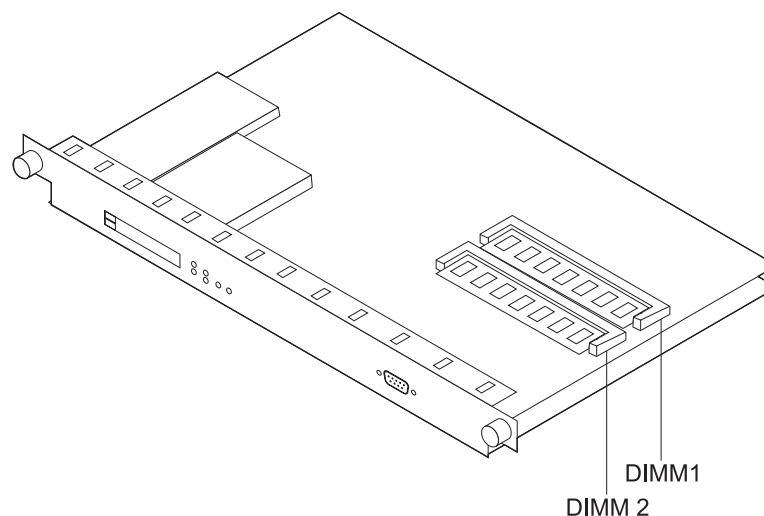

3. Gently slide the DIMM module out of its connector socket.
4. Remove the antistatic bag containing the replacement DIMM from its shipping container.

**Attention:**

Electrostatic discharge (ESD) can damage the static-sensitive devices on circuit boards. To avoid this kind of damage, use the following precautions:

- Do not remove the DIMM until you are ready to insert it into the 2216.
  - Use correct grounding techniques when inspecting and installing the DIMM. Use a foot strap or grounding mat, or wear a grounded static discharge wrist strap, or touch a grounded rack or other source of ground before you handle the DIMM.
5. Remove the DIMM from the antistatic bag. Inspect it for damage. Always handle the DIMM by the ends (preferably grasp it between the middle finger and thumb; do not touch the components). If the DIMM appears to be damaged, return it to the antistatic bag and contact the supplier.
  6. Insert the new DIMM into the appropriate slot. (Grasping the DIMM between the middle finger and thumb, place it connector edge down into the DIMM socket. Applying slight pressure to the top edge of the DIMM, move it forward until it is correctly aligned and snaps in place.)

The lever will snap back into place as the DIMM is fully inserted.

## Model TX1 or TN1

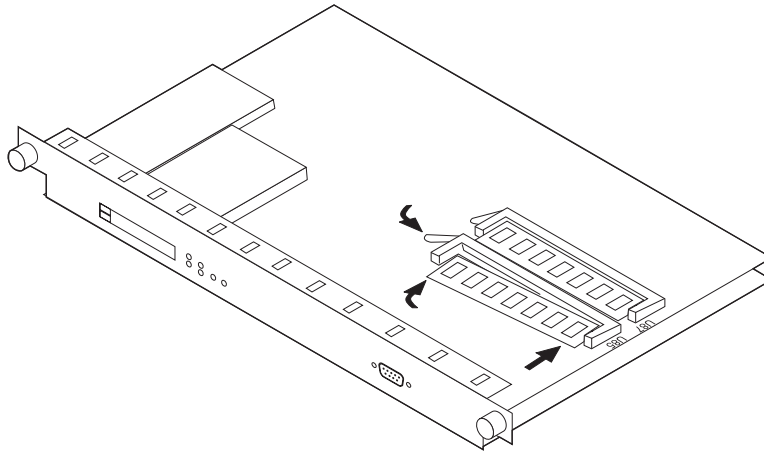

7. If your only task was to remove and replace a DIMM, you are ready to reinstall the system card. Go to “Exchanging the System Card” on page 6-5 at step 7.

## Installing Memory Upgrades on a System Card

Use this procedure to install memory upgrades to your Model TX1 or TN1.

There are slots for two DIMMs on the system card. If you install more than one DIMM, the second DIMM must be the same capacity as the first.

1. Using the instructions included in the Memory Update Kit, identify any DIMMs that are to be removed. See the following figure for the socket designations.
2. Remove the DIMMs by pulling down the lever at the edge of the DIMM socket. (Use your thumbnail or a small non-metallic device to gently move the spring latch away from the end of the DIMM.) The DIMM will automatically be pushed partially out of the slot.

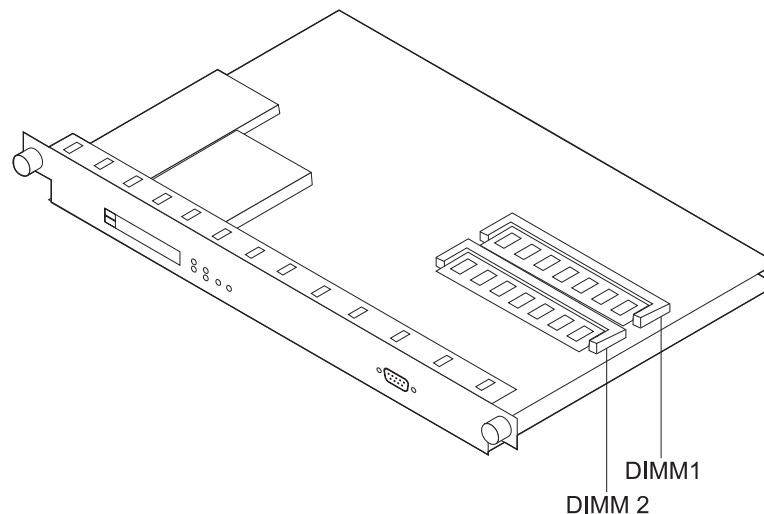

3. Gently slide the DIMM module out of its connector socket.
4. Remove the antistatic bag containing the new DIMMs from its shipping container.

**Attention:**

Electrostatic discharge (ESD) can damage the static-sensitive devices on circuit boards. To avoid this kind of damage, use the following precautions:

- Do not remove the DIMM until you are ready to insert it into the 2216.
  - Use correct grounding techniques when inspecting and installing the DIMM. Use a foot strap or grounding mat, or wear a grounded static discharge wrist strap, or touch a grounded rack or other source of ground before you handle the DIMM.
5. Remove the DIMM from the antistatic bag. Inspect it for damage. Always handle the DIMM by the ends (preferably grasp it between the middle finger and thumb; do not touch the components). If the DIMM appears to be damaged, return it to the antistatic bag and contact the supplier.
  6. Insert the new DIMM into the appropriate slot, according to the Memory Update Kit instructions. (Grasping the DIMM between the middle finger and thumb, place it connector edge down into the DIMM socket. Applying slight pressure to the top edge of the DIMM, move it forward until it is correctly aligned and snaps in place.)

The lever will snap back into place as the DIMM is fully inserted.

## Model TX1 or TN1

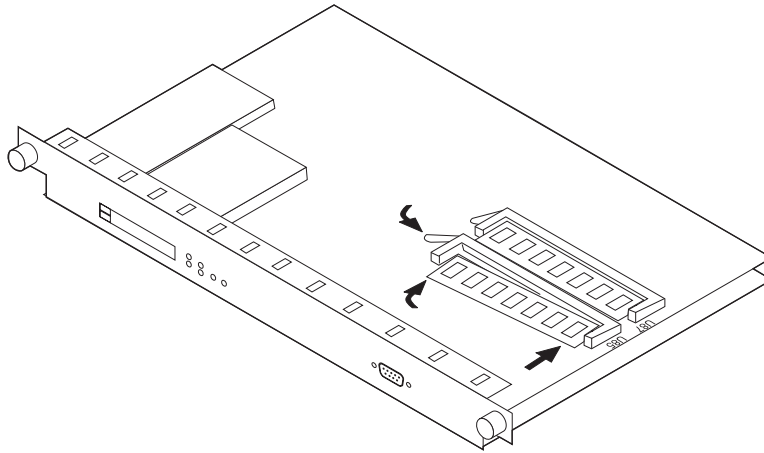

7. If your only task was to install a new DIMM, you are ready to reinstall the system card. Go to “Exchanging the System Card” on page 6-5 at step 7.



---

## Exchanging a Fan

**Attention:** There are two fans in the fan assembly of a Model TX1 or TN1. They are **not** hot pluggable. The Model TX1 or TN1 does **not** automatically shut system power down in the event of either fan's failure. It is necessary to shut down the model TX1 or TN1 on system notification of fan failure before replacing the fan.

To replace the fan:

1. Unplug the power cord.
2. If the Model TX1 or TN1 is installed in a rack, remove it from the rack and place it on a table.
3. Remove screws securing the top cover.
4. Remove the top cover.

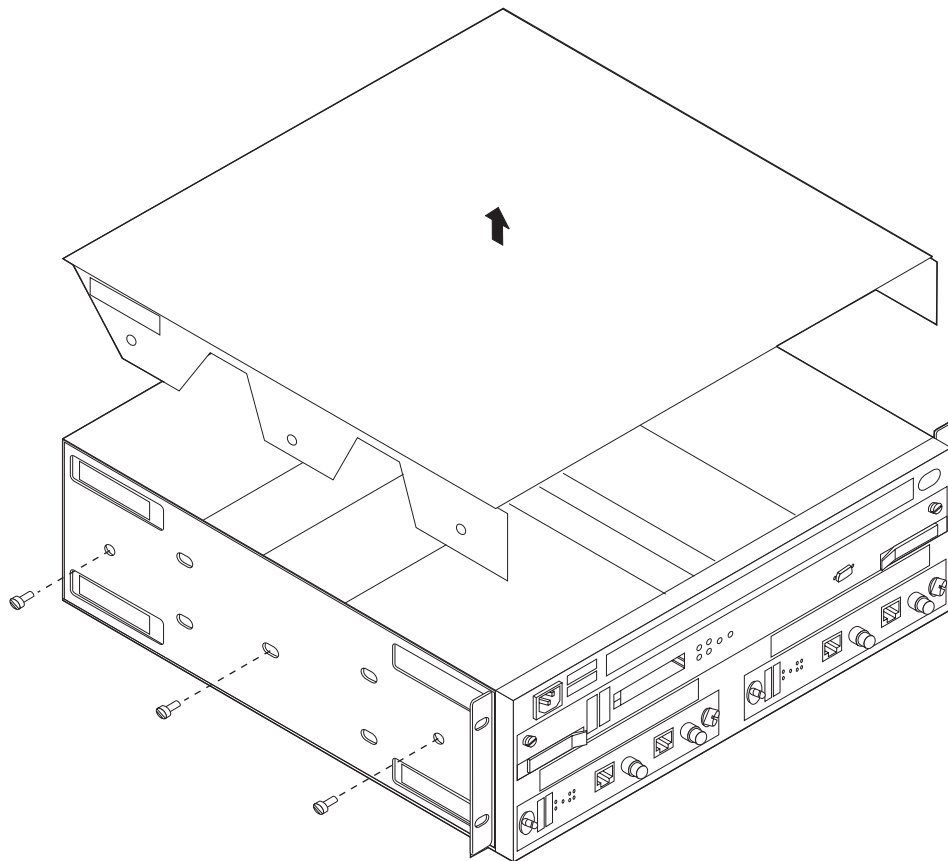

5. Identify the failing fan (by tracing the cable from the backplane connection to the fan).
6. Disconnect the cable assembly of the failing fan from the backplane, making a note of the position to which it is attached.
7. Remove the screws and nuts that secure the failing fan to the Model TX1 or TN1.
8. Remove the wires from the cable guide in the bottom of the unit.
9. Remove the failing fan unit.

## Model TX1 or TN1

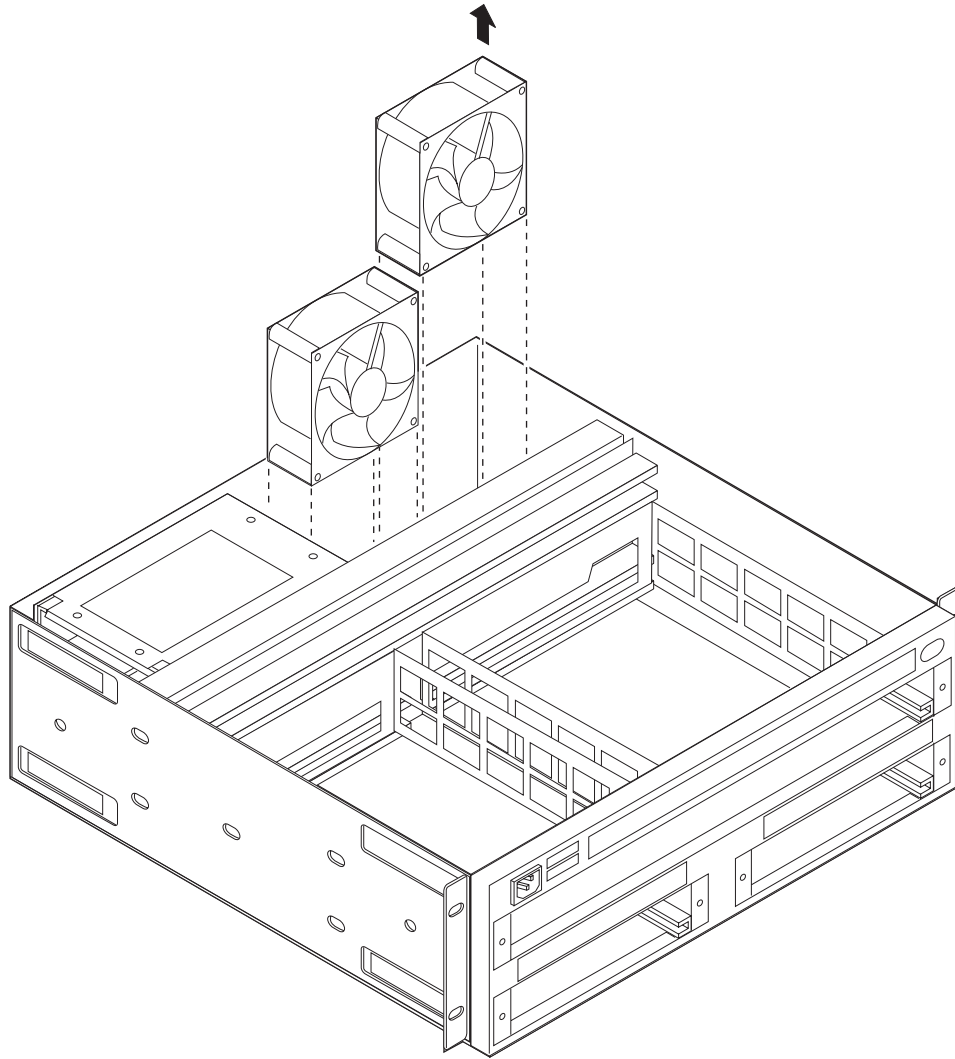

10. Replace the failing fan unit.
11. Replace the screws and nuts that secure the fan unit to the rear wall of the Model TX1 or TN1.
12. Route the cable through the cable guide.
13. Connect the cable assembly of the failing fan to the proper receptacle on the backplane.
14. Replace the top cover.
15. Return the Model TX1 or TN1 to its final rack or table location.
16. Attach the power cord.
17. Verify the system LEDs. See “LED Indicators” on page 2-2.
18. Notify the network administrator that you are finished repairing the Model TX1 or TN1.

## Exchanging an Adapter

**Note:** The adapter you replace must be of the same type as the original. Otherwise, you will need to reconfigure. See the *2216 Nways Multiaccess Connector and Network Utility Introduction and Planning Guide* and the *Multiprotocol Access Services Software User's Guide*.

1. Locate the adapter module to be replaced.

2. **Attention:**

- Adapters are hot pluggable, but you must disable all adapter ports on the adapter that you are removing before you remove cables. See “Disabling an Adapter Slot” on page F-7.
- If an adapter is removed prior to disabling the ports, a machine check can occur and the Model TX1 or TN1 may become idle.

3. Label the cables for correct reconnection.

4. If you are removing a Parallel Channel Adapter (LIC 299), perform the steps in “Removing Channel Adapters” on page 4-13 beginning with step 1 on page 4-13. (This requires a channel-trained service person.)

5. Loosen the screws (if present) that secure the cable or cables.

6. Remove the cable or cables.

**Attention:** You must turn the adapter's thumbscrews simultaneously when unseating or seating the adapter during removal or installation. By doing so, you prevent stripping the thumbscrews. If you strip the thumbscrews, you may not be able to seat or reseat the adapter correctly.

7. Loosen the thumbscrews on the adapter.

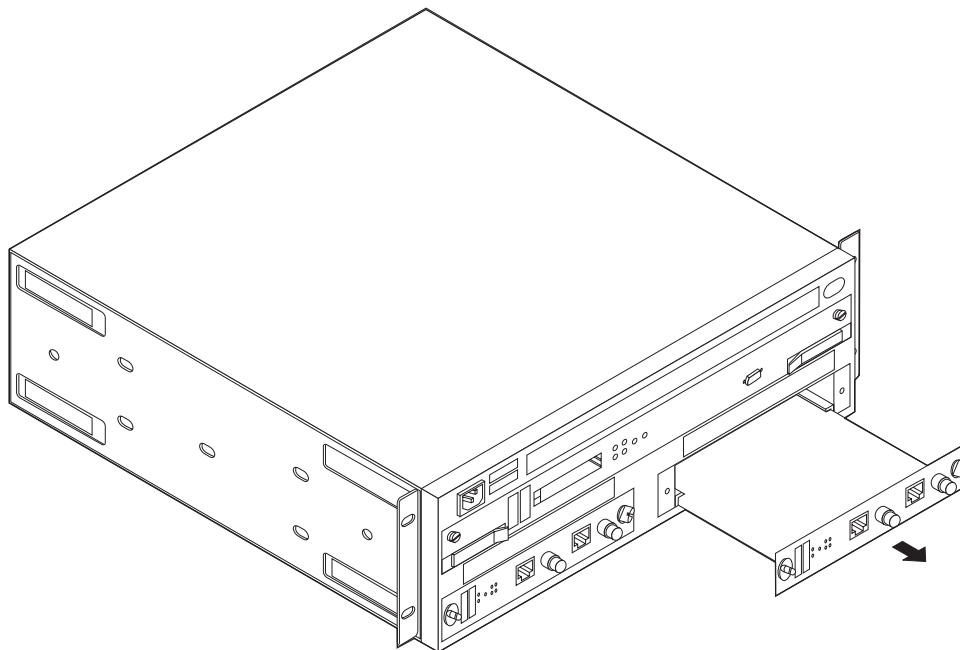

8. Remove the adapter from its location.

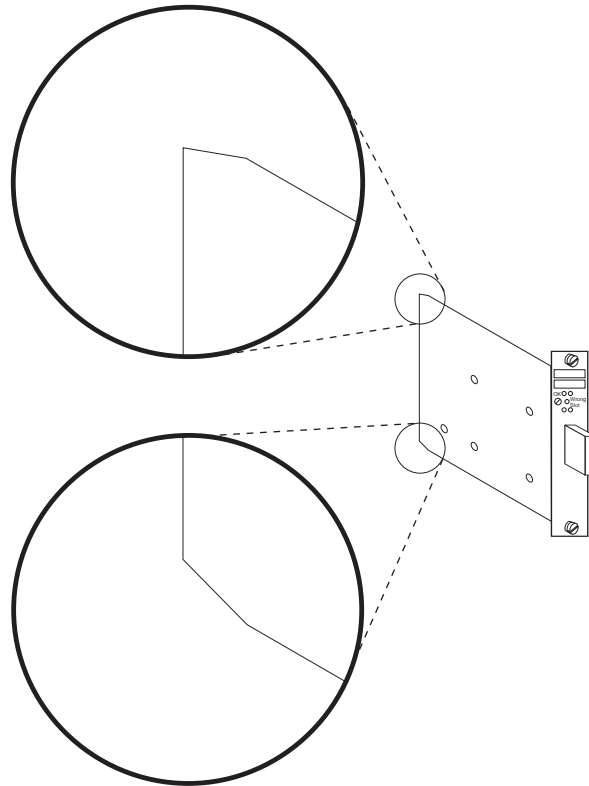

9. Install the new adapter. Notice the notches at the adapter card's angled corners and position them on the left as illustrated.

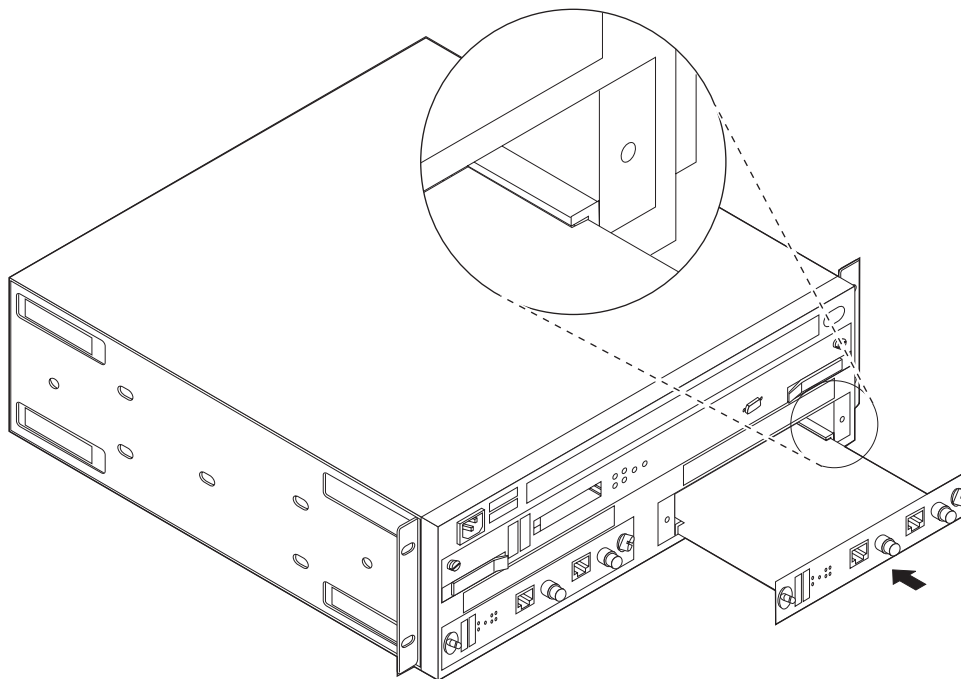

10. Carefully position the notches of the adapter card in the appropriate adapter slot's right and left rails. Then, guide the adapter forward on the rails as pictured.

11. Make sure that the tray on the adapter card is aligned with the plastic grooves and then slide it in until the thumbscrews contact the frame.

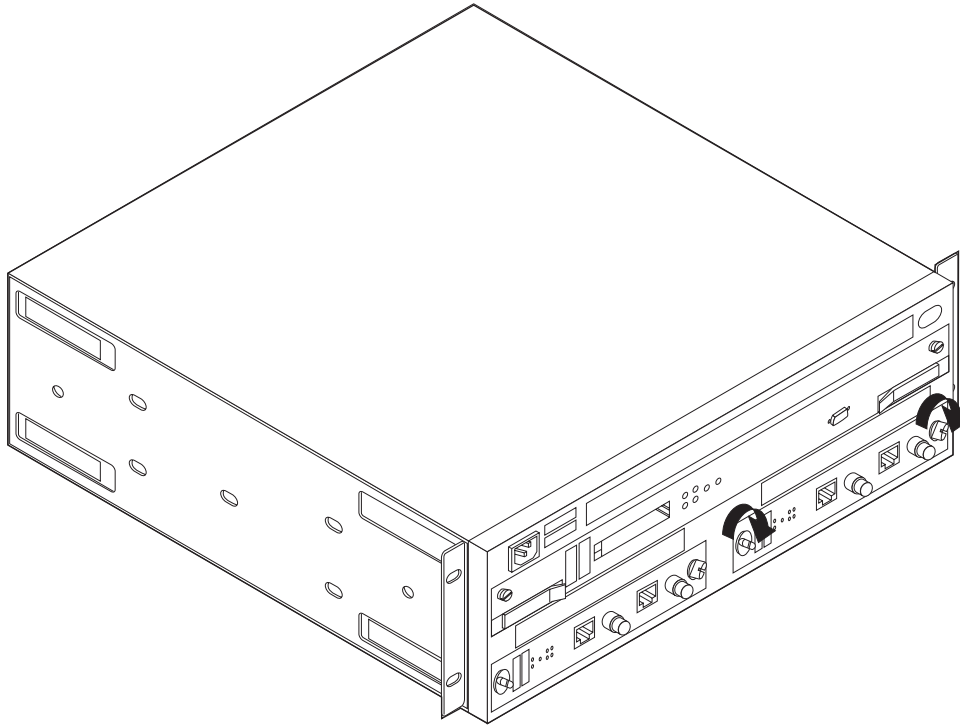

When the card makes full contact with the rear of the Model TX1 or TN1, press and simultaneously turn each thumbscrew on the face of the adapter card clockwise, **only** until the adapter is firmly seated.

12. Secure the module by tightening the screws.
13. Check that the green LED of the adapter comes ON and that the Wrong Slot LED is OFF. If not, check the adapter installation. If the problem persists call the support center. Otherwise, continue.
14. If you are replacing a Parallel Channel Adapter, perform the steps beginning with step 1 on page 4-10.
15. Replace the removed cable or cables, then tighten the cable screws (if present).
16. Re-enable all adapter ports. See “Enabling an Adapter Slot” on page F-7.

---

## Exchanging the Backplane

**Note:**

1. Unplug the power cord from the power receptacle.
2. Label the cables with the adapters and ports they plug into. Unplug all the cables.
3. Make a note of the slot position of each card in the unit.
4. Remove the:
  - System card (see “Exchanging the System Card” on page 6-5 steps 1 through 4).

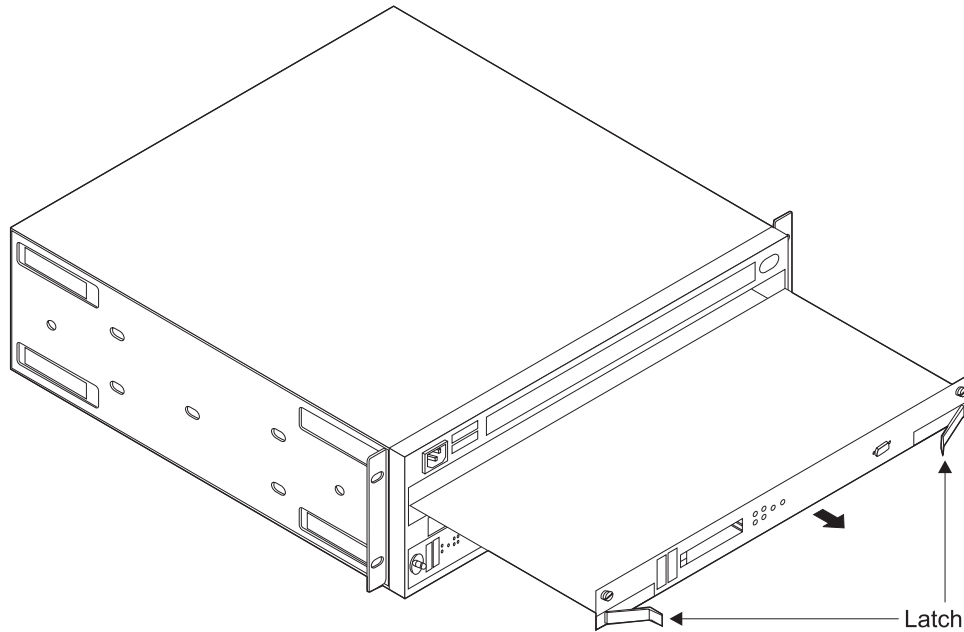

- Adapters (see “Exchanging an Adapter” on page 6-15 steps 1 through 8).

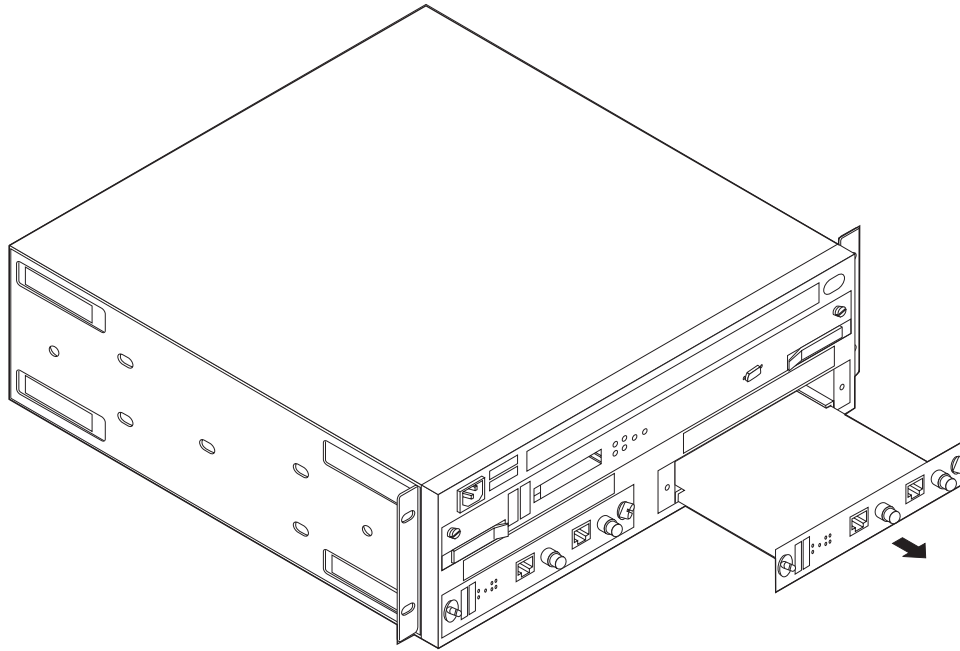

5. If the Model TX1 or TN1 is rack-mounted continue with step 6; otherwise, go to step 9 on page 6-20.
6. Remove the screws from the rack-mounting brackets.

## Model TX1 or TN1

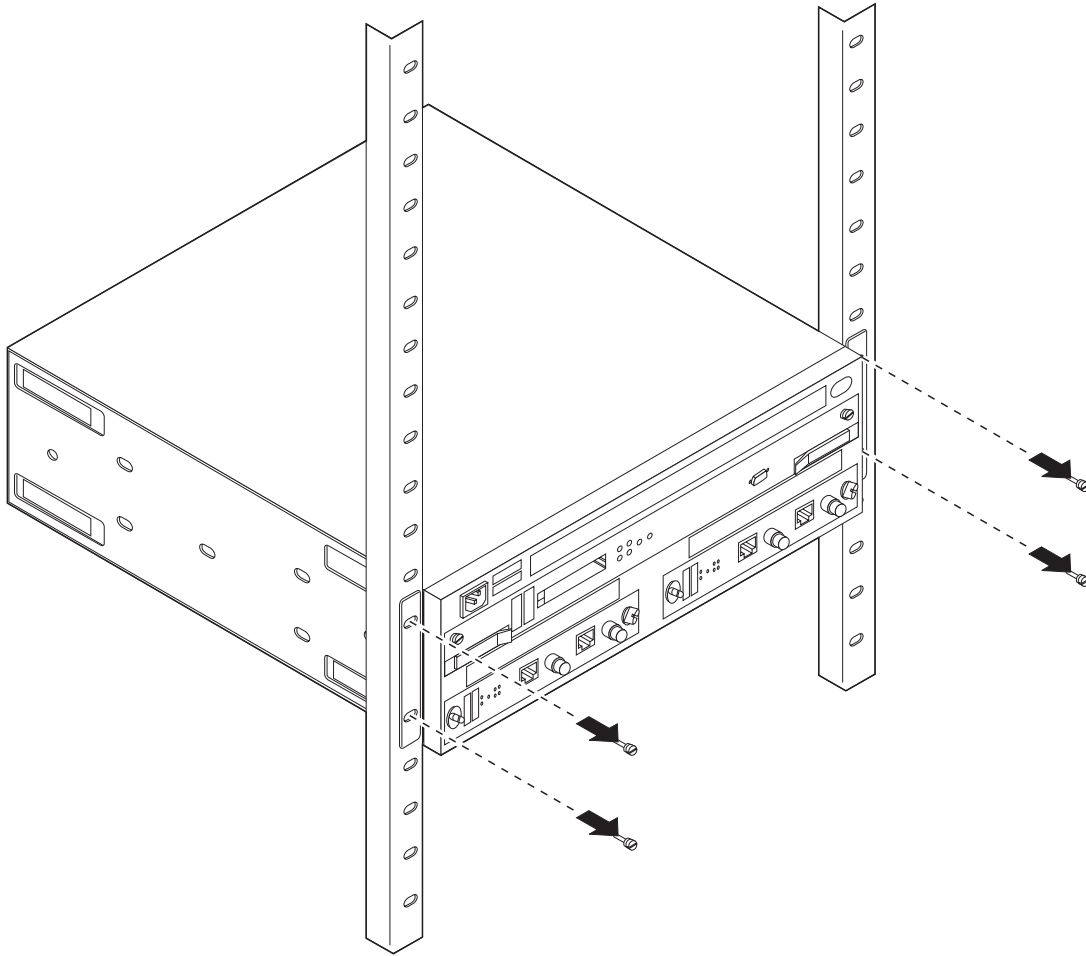

7. Hold the Model TX1 or TN1 from the top of the back and bottom of the front, and then slide it forward out of the rack.
8. Place the Model TX1 or TN1 on a table.
9. Remove the system cover.
10. Near the right end of the backplane assembly, disconnect the power cables for the:
  - Power assembly
  - Fan units
11. On each side of the Model TX1 or TN1, remove the two screws along the side panels that hold the backplane in place.
12. Remove the two nuts and star washers connecting the backplane to the inside of the Model TX1 or TN1.



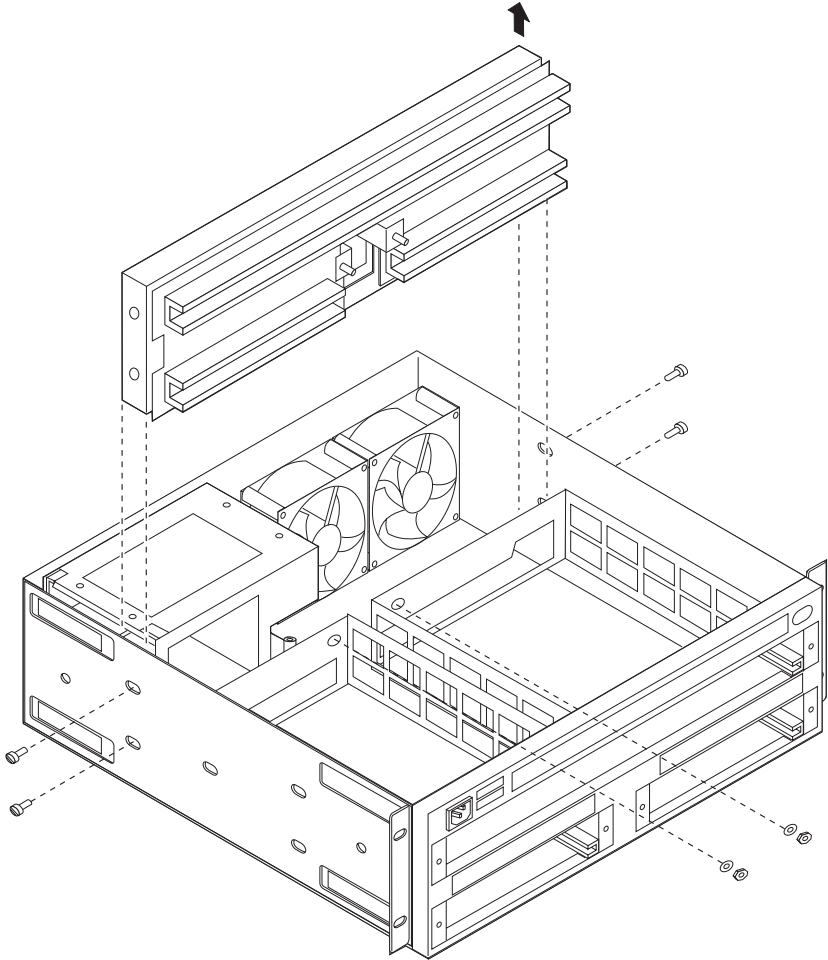

13. Move the backplane towards the rear, and lift it straight out of the Model TX1 or TN1.

## Model TX1 or TN1

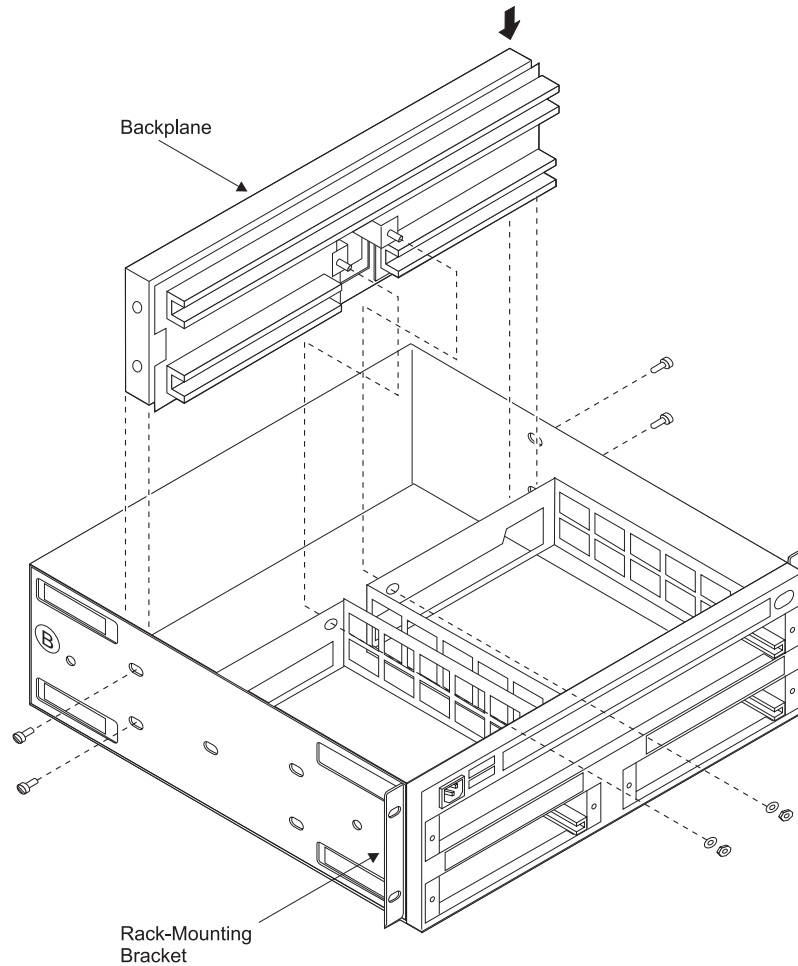

14. Hold the new backplane, and lower it gently into the Model TX1 or TN1.
15. Align the screw holes on the backplane with those on the sides of the box.
16. Reach inside the Model TX1 or TN1, grasp the bottom middle of the backplane, and press it up and toward you until all the bulkhead screws protrude through the chassis.
17. Loosely install a screw on each side of the Model TX1 or TN1.
18. Loosely insert the remaining screws on each side.
19. Install and tighten the two nuts and star washers inside the Model TX1 or TN1 that secure the backplane to the system.
20. Tighten the screws along the side of the box that hold the backplane in place.
21. Reconnect the power assembly cables to the backplane.
22. Reconnect the fan cables.
23. Reinstall the system cover.
24. Mount the Model TX1 or TN1 in the rack if appropriate. It is recommended that you use a screw starter here.
  - a. Slide the Model TX1 or TN1 into the rack.
  - b. Install the four screws that secure the unit to the rack.

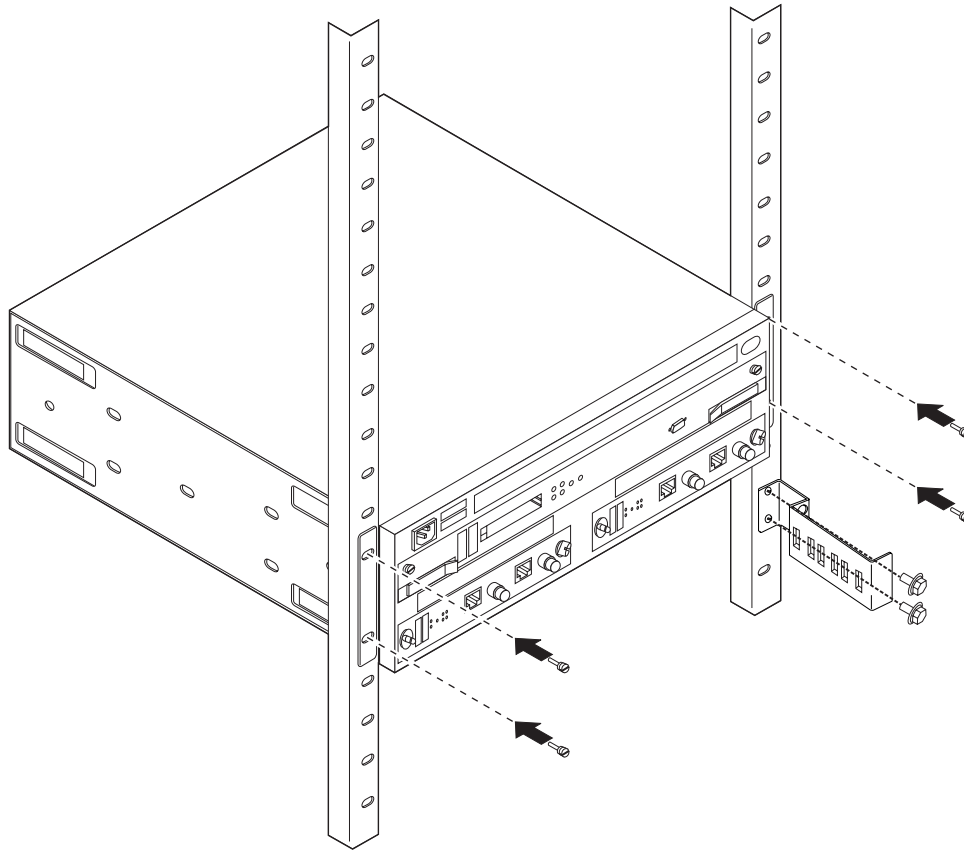

25. Reinstall the system card. Make sure the card is aligned with the plastic grooves and then slide it in until it is flush with the box. (See “Exchanging the System Card” on page 6-5 steps 7 through 10 for details). Tighten the screws.
26. Reinstall the adapters. Slide each adapter in along the plastic grooves (see “Exchanging an Adapter” on page 6-15 steps 9 through 12 for details).
27. Reconnect the cables.
28. Reconnect the power cord to the power receptacle.
29. Verify the LEDs. See “LED Indicators” on page 2-2
30. Notify the network administrator that you are finished repairing the Model TX1 or TN1.



---

## Chapter 7. Accessing the Model 400 and Network Utility

---

### Access Methods

You can access and connect to the 2216 Model 400 or Network Utility in several ways that are summarized in Table 7-1.

Physical Attachment	Line Protocol	Access Protocol	Default IP Addresses
Service port + null modem Service port + external modem PCMCIA modem	Asynchronous characters	ASCII Terminal emulation	Not Applicable
	SLIP	Telnet	2216 Model 400 or Network Utility = 10.1.1.2 Workstation = 10.1.1.3
PCMCIA EtherJet (Network Utility only)	IP	Telnet	Network Utility = 10.1.0.2 Workstation = 10.1.0.3
Any IP network interface	IP	Telnet	No defaults

Make the physical connections in one of the following ways when you want to use:

1. An **ASCII terminal** or a **workstation** that is running terminal emulation software:
  - Local connection through a null-modem cable attached to the EIA 232 service port (see Figure 7-1 on page 7-2). This type of connection uses the null-modem adapter and the two 9-to-25 pin serial cables that are supplied with this product.
  - Remote dial-in (using telephone lines) through the PCMCIA modem (see Figure 7-2 on page 7-2).
  - Remote dial-in (using telephone lines) with an external modem (not pictured) attached to the EIA 232 service port. This configuration would be used in countries where there is no approved PCMCIA modem. Use an asynchronous modem that supports the Hayes AT command set. To determine which modems are supported, refer to the product literature sales pages at: [www.networking.ibm.com/216/216prod.html](http://www.networking.ibm.com/216/216prod.html).
2. The **Telnet protocol** on a workstation that is running TCP/IP software:
  - Any of the physical connections that are described in the methods in alternative 1.

For these physical connections, the Telnet workstation is running TCP/IP software that supports the Serial Line Internet Protocol (SLIP). SLIP is a method for sending IP packets across asynchronous lines.

Telnet over SLIP provides access only to the operational code command-line interface, and not to the firmware menu interface.
  - Local cable from a Network Utility PCMCIA LAN adapter (an IBM EtherJet PC card) to a workstation using a local Ethernet hub. Figure 7-4 on page 7-3 shows a version of this configuration.

The workstation Ethernet adapter could also be directly attached to the EtherJet card via a crossover cable, or there could be a wide area network between the Ethernet LAN and the Telnet workstation.

The Network Utility IBM EtherJet PC card is for service and operations purposes, such as providing a user console and transferring files. It cannot be used as a normal network routing interface.

- A network-connected workstation that is attached to any IP-capable network interfaces of the adapters that are in the adapter slots.

This configuration is not pictured. The network interface could be on a LAN adapter such as Token-Ring, 10/100-Mbps Ethernet, or FDDI. It could also be on any other adapter, because all of them support IP routing. The Telnet workstation could be locally or remotely connected.

2216 Model 400  
or Network Utility

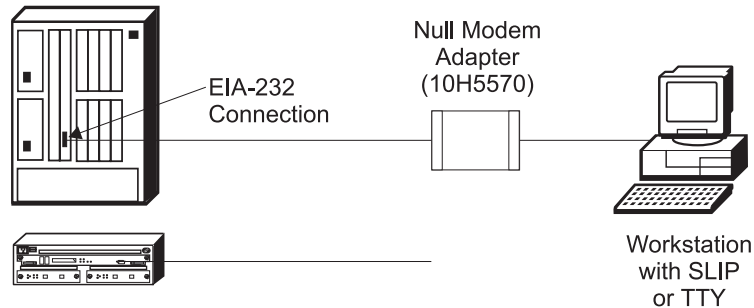

Figure 7-1. Local Workstation Serial Connection to the EIA 232 Port

2216 Model 400  
or Network Utility

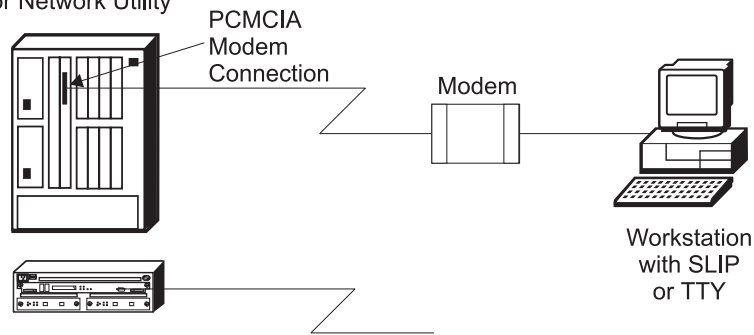

Figure 7-2. Remote Serial Connection to the PCMCIA Modem

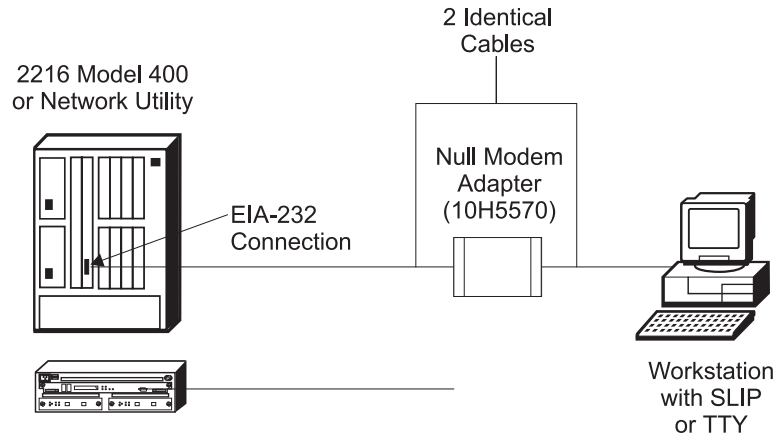

Figure 7-3. Local 9-pin Workstation Serial Connection to the EIA 232 Port

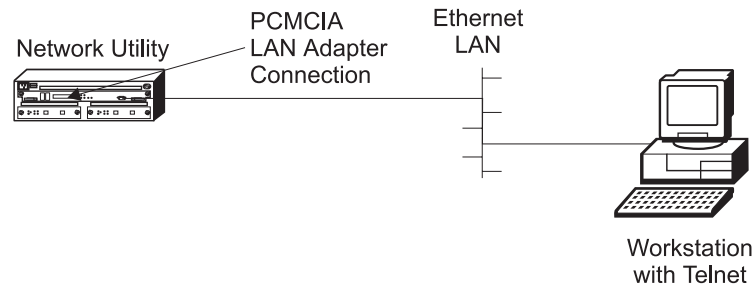

Figure 7-4. LAN Connection through the PCMCIA LAN Adapter. This connection type is only available for the Network Utility.

## ASCII Terminal Setup and Usage

Use this section if you are setting up an ASCII terminal or a workstation with terminal emulation. You can use ASCII terminal emulation to access 2216 Model 400 or Network Utility whether or not it has ever been configured.

An ASCII terminal console provides access both to the main operational code (the command-line interface), and to the firmware user interface (see Chapter 8, “Using the Firmware” on page 8-1). If you are remotely dialed-in to the PCMCIA modem and you reboot the unit, you will lose your console connection and need to re-dial. If you are locally connected or remotely dialed-in to an external modem attached to the service port, your console connection is maintained during a reboot.

### Attaching an ASCII Terminal

Attach an ASCII terminal or emulator (with the appropriate emulation software) to provide local or remote access as shown in Figure 7-2 on page 7-2 and Figure 7-1 on page 7-2. DEC VT100 and DEC VT220 ASCII terminals are supported, as well as devices such as personal computer systems that are configured to emulate them.

## Serial Port and PCMCIA Modem Default Settings

These are the default settings for the serial port:

<b>Speed</b>	19.2 Kbps
<b>Parity</b>	None
<b>Data Bits</b>	8
<b>Stop Bits</b>	1
<b>Terminal type</b>	VT220, Monochrome

The PCMCIA modem is a standard item that is shipped with the 2216 Model 400 or Network Utility in most countries. It is a 33.6 Kbps V.34 data modem, and it negotiates the data rate to be used between it and the partner modem on the other side of the telephone network. Using data compression, this modem is capable of data throughput greater than 33.6 Kbps.

The data rate between the Network Utility system and its PCMCIA modem defaults to 19.2 Kbps, but you can raise it to accommodate the higher throughput that the two modems may be able to achieve between themselves. For example, you may want to set this rate to 57.6 Kbps so that it is higher than the effective data rate of two 33.6 Kbps modems running data compression. If your modems are both faster than 19.2 Kbps, raising this rate will lower Xmodem file transfer time.

## ASCII Terminal Setup Attributes

This is a list of all the options required to set up a terminal or terminal emulator that is connected to the Network Utility service port. Not every terminal (particularly 3151 and 3161) will have all these options. You should use the information to set the options that you can set on your terminal.

### Terminal Settings and Function Keys

<b>Baud Rate:</b>	19200 bits per second
	<b>Note:</b> Baud rate must match the speed of the Network Utility serial service port.
<b>Parity:</b>	None
<b>Data bits:</b>	8
<b>Stop bits:</b>	1
<b>Duplex:</b>	Full Duplex
<b>Flow Control:</b>	XON/XOFF and RTS/CTS (see Note 1)
<b>Screen Control:</b>	ANSI Full screen
<b>Screen Width:</b>	80 Characters
<b>Screen Height:</b>	24 Lines
<b>Line Wrap:</b>	ON
<b>Screen Scroll:</b>	ON
<b>Carriage Return Translation:</b>	CR (0Dx)
<b>Backspace Translation:</b>	Destructive



**Notes:**

1. Set terminals and terminal emulator programs that do not have flow control options to “Permanent Request to Send.”
2. Set terminal emulators that require a terminal type selection to VT-220.

**Function Keys**

When accessing the firmware, you will need to use function keys F1, F2, F3, F4, F6, and F9. Not all terminals or terminal emulators provide standard support for these function keys (for example, the VT100 types).

The simplest way to simulate these functions keys is to type the following sequence, with no more than two seconds between each step:

1. **Ctrl-a**
2. The number (not the function key itself) of the function key you want
3. **Enter**

Alternatively, you can set up your terminal emulator to generate the following escape key sequences when you press a function key:

Function 1 (F1):	<Esc> 0 P	Hex: 1B 4F 50
Function 2 (F2):	<Esc> 0 Q	Hex: 1B 4F 51
Function 3 (F3):	<Esc> 0 R	Hex: 1B 4F 52
Function 4 (F4):	<Esc> 0 S	Hex: 1B 4F 53
Function 6 (F6):	<Esc> [ 0 0 6 q	Hex: 1B 5B 30 30 36 71
Function 9 (F9):	<Esc> [ 0 0 9 q	Hex: 1B 5B 30 30 39 71

**Note:** In the definitions of function keys:

0 = uppercase O  
 0 = the number zero  
 All characters are case-sensitive

**Multiple Terminal Users**

One user at a time can have an active terminal console through the system card serial port or the PCMCIA modem interface. If a workstation is connected locally to the serial port and a call comes in over the PCMCIA modem, priority is given to the call. After the call, the user at the local workstation will have to reconnect.

**Telnet Setup and Usage**

Use this section if you are setting up Telnet terminal console access.

Telnet provides access only to the main operational code (the command-line interface), and not to the firmware user interface. If you reboot the unit from the command-line interface, you lose your Telnet connection and you need to re-establish it after the unit has rebooted.

If your unit has never been configured, the only way you can Telnet to it is by using the default SLIP or PCMCIA EtherJet IP addresses.

## SLIP Addresses

The default SLIP IP addresses for use with the PCMCIA or external modems are:

**For the workstation:**

10.1.1.3

**For the 2216 Model 400 or Network Utility:**

10.1.1.2

For instructions about installing SLIP, refer to the documentation for your version of TCP/IP PC software.

## PCMCIA LAN IP Addresses

The default IP addresses for use with the PCMCIA EtherJet PC card are as follows:

**For the workstation:**

10.1.0.3

**For the Network Utility:**

10.1.0.2

You can change these addresses either from the operational code command-line interface or from the firmware. (Use the procedures that are documented in “Configuring IP Addresses for a PCMCIA LAN Adapter” on page F-11.) You must first bring up your initial user console using ASCII terminal emulation or by telnetting to the default IP addresses.

## Network Interface IP Addresses

There are no default IP addresses for network interfaces (those on the adapters in the adapter slots). Use either the command-line interface or the Configuration Program to set up IP addresses for network interfaces. You cannot Telnet in through a network interface until you activate the IP address configuration change.

In addition to assigning IP addresses to an interface, you can assign one to the entire unit. This IP address is known as the *internal* IP address, and it remains active independent of the state of individual network interfaces.

If you have a Model TN1 and are using the TN3270 server function, you must configure the IP address and TCP port number to be used by TN3270. If you accept the default Telnet port number 23 for TN3270, you must attach your console Telnet sessions to a different IP address than the one you have configured for the TN3270 server. This allows the unit to distinguish console Telnet sessions from TN3270 client sessions.

## Multiple Telnet Users

Two users at a time can bring up Telnet consoles through network interfaces. A third user's Telnet attempt will be rejected until one of the first two users has disconnected. One user at a time can have an active console through the system card service port or PCMCIA interfaces, including Telnet through SLIP or the PCMCIA LAN card.

---

## Chapter 8. Using the Firmware

The 2216 base (2216 Model 400 and Network Utility) firmware tests the hardware each time the 2216 is powered on. If the 2216 has not loaded its operational code, the firmware should be running. The firmware menu will come up and pause when the 2216 is set up to boot up in "Supervisory/Attended Mode." Supervisory Mode requires direct intervention from console input to complete the boot-up process (a supervisory password is required).

### Important:

1. You can also access the firmware by stopping the boot process. To do this, you must have a TTY console directly attached to the serial port and a null modem.
2. To access the firmware:
  - a. When the 2216 starts its boot process, press **F1** or **Ctrl-C** at the terminal keyboard.
  - b. If the firmware panels do not appear:
    - 1) Make sure your workstation is connected to the serial port on the IBM 2216
    - 2) Power off and power on the Model 400.

Unplug and plug in the power to the Network Utility.

**Note:** Make sure the screen size for your terminal emulation software is set to 80 columns by 24 rows.

Connection in Supervisory mode is a TTY (using limited VT100, VT220, IBM 3151 or 3161 emulation) connection. You can transfer files using the Xmodem protocol for TTY.

---

### Supervisory/Attended Mode

When the 2216 is configured to come up in Attended mode, you are given access to the Firmware command set. (A supervisory password is required for access to the firmware.) From this level of commands, you can select the Image Bank from which to load. You can also choose the config file from within that Image Bank. At this point, you can load new config files or image files.

In Attended mode, you can start booting the 2216 by pressing **F9** to start the operating system.

---

### Unattended Mode

This is the normal mode for the 2216 base configuration. (A password is not required to access the firmware in unattended mode.) To do this, you must have a TTY console directly attached to the serial port and a null modem.

---

## Starting Firmware

You are ready to begin using the information in this chapter after you have prepared your service terminal (as described in “Attaching an ASCII Terminal” on page 7-3) and have established connection with the 2216.

The firmware menu will come up when you power on the 2216 and stop the boot process by pressing **F1**. From the menu (as shown in Figure 8-1), you can select from four services. The following sections explain these services and provide instructions for using the associated panels:

- “Managing the Configuration” on page 8-3.
- “Selecting the Boot Sequence” on page 8-5.
- “Selecting a Device To Test” on page 8-7.
- “Using the Utilities” on page 8-8.

```
Nways System Firmware
Version 1.0
(C) Copyright IBM Corporation, 1996 All Rights Reserved.
                        System Management Services

Select one:
 1. Manage Configuration
 2. Boot Sequence Selection
 3. Select Device to Test
 4. Utilities

Enter   -   Esc=Quit   -   F1=Help   -   F3=Reboot   -   F9=Start OS -
-----
```

Figure 8-1. Main Menu Panel

---

## The Function Keys

As seen in Figure 8-1, various function keys appear in the lower part of the panel. (You can also use the **Esc** keys in combination with number keys to perform the functions.) These keys are common among the firmware panels. On other panels, the function keys are stacked at the right of the panel. Use the **F1 Help** key (or **Esc - 1**) to get descriptions for the function keys associated with the firmware.

---

## Obtaining Help

Online helps are available for panels whenever the F1 key is displayed in the lower portion of the panel. Pressing F1 presents a pop-up help window with information relating to the currently active panel.

---

## Managing the Configuration

Managing the configuration involves defining and modifying some configuration values. You can change operational parameters for the serial ports, as well as the values of the boot flags.

1. Select **1. Manage Configuration** from the main menu as shown in Figure 8-1 on page 8-2.
2. The System Configuration Information panel is displayed as shown in Figure 8-2 on page 8-4. Only the fields under Serial Ports and Boot Flags can be modified.
3. To modify a field, move the cursor to the field, press **Enter**, and select or type in the new value.
4. For serial ports, you can modify the port or PCMCIA modem's speed, parity, and the number of data and stop bits. Boot flags are defined as follows:

### Fast Boot

- disabled** The default. When disabled all diagnostics are run on every boot attempt.
- enabled** The router skips Power On Self Test hardware diagnostics, resulting in a faster boot time but less hardware error checking.

### Stop On Error

- disabled** The default. When disabled, the router proceeds booting the operating system without regard to diagnostic results.
- enabled** The router stops the boot sequence in the firmware if any of the POST diagnostic tests fail, instead of proceeding to boot the router operating system. You may then view the error log to determine the cause of failure.

### Notes:

- a. This option is ignored when Fast Boot is enabled.
- b. This option does not affect the PCI diagnostics that are run at boot-time by the router operational code.
- c. POST diagnostics check out the system card, memory, and hard disk. They can report errors that would not actually prohibit the router from operating successfully.

Use the down arrow (↓) key to scroll to the next panel.

```

Nways System Firmware
Version 2.10
(C) Copyright IBM Corporation, 1997. All rights reserved.
+-----System Configuration Information-----+
Se | Processor Type          133 MHz 604
1  | Memory                  64 Megabytes                >
2  | Serial Ports
3  |   COM1 (x' 3f8')       Serial Port                >
4  |   COM2 (x' 2f8')       PCMCIA Modem                >
   |
   | Boot Flags
   |   Fast Boot            Disabled                >
   |   Stop On Error        Disabled
   |
   | L2 Cache                512KB Installed
   |
   | PCI Slots
   | Name of Adapter      Slot #      Device ID      Revision ID
   | 060000                B           0037           02
   | 060100                B           000a           03
   | Unknown( 0001 010000 ) B           0100           01
   | 060400                B           0022           01
   | 060400                B           0022           01
   | Unknown( 104c 060700 ) B           ac15           01
   | ff0000                B           0046           00
   |
   | Enter - Esc=Quit - F1=Help -
   | -----
+-----+

```

Figure 8-2. System Configuration Information

## Selecting the Boot Sequence

This function enables you to select a sequence for the various boot devices, display the current boot device settings, restore the default setting, and boot from other boot devices. To select a boot sequence:

1. Select **2. Boot Sequence Selection** from the main menu.
2. The Boot Sequence Selection panel is displayed as shown in Figure 8-3.

```
Nways System Firmware
Version 1.0
(C) Copyright IBM Corporation, 1996 All Rights Reserved.
                        System Management Services

Select one:
 1. Manage Configuration
 2. Boot Sequence Selection-----+
 3. Select Device to Test
 4. Utilities

      1. Select 1st Boot Device
      2. Select 2nd Boot Device
      3. Select 3rd Boot Device      Enter -
      4. Select 4th Boot Device      -----
      5. Select 5th Boot Device      Esc=Quit -
      6. Display Current Settings      -----
      7. Restore Default Settings
      8. Boot Other Device

      +-----+

Enter - Esc=Quit - F1=Help - F3=Reboot - F9=Start OS -
-----
```

Figure 8-3. Boot Sequence Selection Panel

3. Select one of the options (1 through 4) and press **Enter**. The appropriate Boot Device Selection panel will be displayed. Default boot devices are:
  - None
  - IDE hard drive
  - Network adapter (IBM PCMCIA Modem)
  - Network adapter (IBM SLIP, Com 1 Direct)
4. Highlight your choice and press **Enter**.
5. Repeat step 3 and step 4 to select as many boot devices as you want to define.
6. Press **Esc** to exit the boot sequence selection menu.
7. Press **F3** to reboot the 2216 and make your boot device change effective.

**Note:** To restore the defaults, select option 7 before you reboot the 2216. The default boot device settings will then be restored. The Current Boot Sequence will be displayed as in Figure 8-4 on page 8-6.

```
Nways System Firmware
Version 1.0
(C) Copyright IBM Corporation, 1996 All Rights Reserved.
      System Management Services

Select one:
1. Manage +-----Current Boot Sequence-----+
2. Boot Se |
3. Select   | Your current boot sequence is:
4. Utiliti |
           | 1. IDE Disk Drive      ID 0, IBM-DS0A-21080
           | 2. PCMCIA Modem       Not installed
           | 3. EIA 232 Port      ID 0, IBM SLIP, EIA 232 Port
           | 4. None
           | 5. None
           |
           | Enter -
           | -----
           |
-----+-----+-----+-----+-----+
Enter - Esc=Quit - F1=Help - F3=Reboot - F9=Start OS -
-----+-----+-----+-----+-----+-----+

```

Figure 8-4. Current Boot Sequence



### Selecting a Device To Test

Extensive hardware tests are performed by the 2216 base firmware at boot up time. But there may be times when you have removed and replaced a failing part and you want to run an individual test before a full bootup or reset. The firmware allows you to run these individual tests:

- Test All Subsystems: This test runs all the subsystem tests that are listed on this panel.
- Test Memory: This test searches all available memory regions, tests the regions, and presents a consolidated list of test results.
- Test System Board: This tests the PowerPC CPU, the System Board interrupts, and the PCMCIA controller.

1. Select **3. Select Device to Test** from the main menu.
2. The Select Device to Test panel is displayed (see Figure 8-5).

**Note:** The Select Device to Test panel is created dynamically, depending on what diagnostics have been loaded, but the items shown always appear.

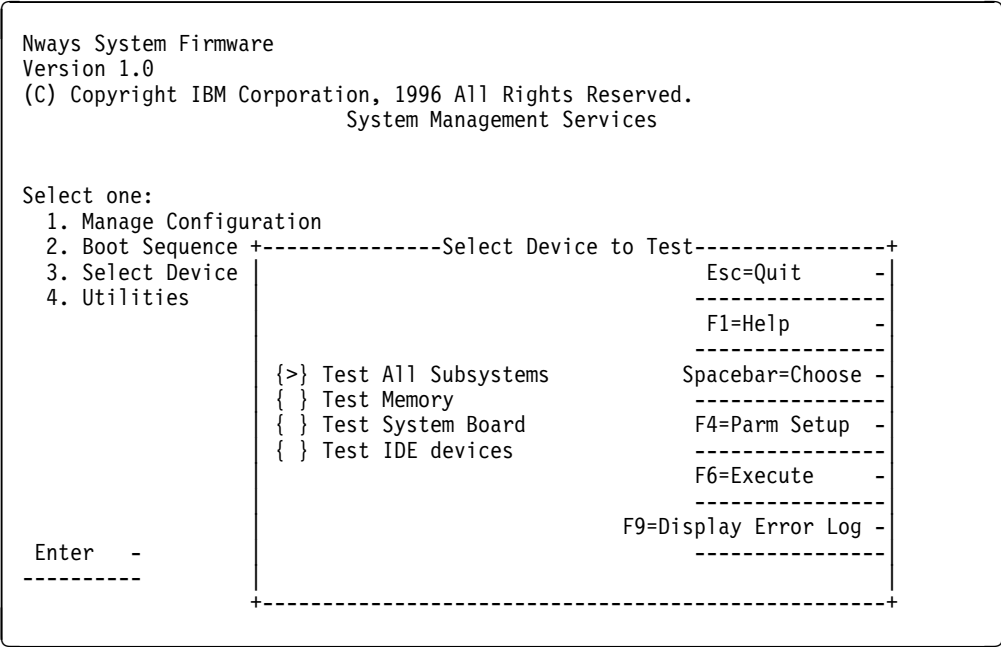

Figure 8-5. Test Selection Panel

3. Use the spacebar and up arrow and down arrow keys to select the test.
4. Press **F4** to define additional test parameters.
 

**Note:** Errors encountered during diagnostics are logged in the hardware error log.
5. Press **F6** to start a test.
6. After the test is complete, press **Esc** to return to the main menu panel.

---

## Using the Utilities

To use the utilities:

1. Select **4. Utilities** from the main menu.
2. A menu listing the available utilities is displayed (see Figure 8-6).

```
Nways System Firmware
Version 1.0
(C) Copyright IBM Corporation, 1996 All Rights Reserved.
                        System Management Utilities

Select one:
 1. Set Power-On Password
 2. Set Supervisory Password
 3. Enable Unattended Start Mode
 4. Disable Unattended Start Mode
 5. Remove Power-On Password
 6. Remove Supervisory Password
 7. Update System Firmware
 8. Display Error Log
 9. View or Set Vital Product Data
10. Manipulate Dead Man Timer
11. Remote Initial Program Load Setup
12. Change Management
13. Prepare Hard Disk
Enter   -   Esc=Quit   -   F1=Help   -
-----
```

Figure 8-6. Utilities Selection Panel

3. Make your selection. You will be prompted for additional information, and messages are displayed to indicate that the task was performed.

## Setting the Power-On Password

If a password is set/installed and the 2216 is not in unattended mode, you must set a power-on password before operational code can be loaded in the 2216. The initial password is set at manufacturing to **2216**. This firmware utility options allows you to set and change the password.

This function can be performed only if done immediately after switching the power on.

1. Select **1. Set Power-On Password** from the System Management Utilities panel. The Set Power-On Password panel is displayed (see Figure 8-7).
2. Type your new password and press **Enter**. You are prompted to enter your new password again.

**Note:** The power-on password can consist of from 1 to 8 characters with no restrictions on which characters can be used.

```
Nways System Firmware
Version 1.0
(C) Copyright IBM Corporation, 1996 All Rights Reserved.
                        System Management Utilities

Select one:
 1. Set Power-On Password-----Set Power-On Password-----+
 2. Set Supervisor
 3. Enable Unattended
 4. Disable Unattended
 5. Remove Power-On Password
 6. Remove Supervisor
 7. Update System
 8. Display Error
 9. View or Set Variables-----+
10. Manipulate Dead Man Timer
11. Remote Initial Program Load Setup
12. Change Management
13. Prepare Hard Disk
Enter - Esc=Quit - F1=Help -
-----
```

Figure 8-7. Set Power-On Password Panel

3. Type the password again and press **Enter**.
4. The Password Saved panel is displayed with the message that your power-on password has been saved.

## Setting the Supervisory Password

If a supervisory password is set, the password must be entered prior being able to access to the "System Management Services." You must set a supervisory password before operational code can be loaded in the 2216. The initial password is set at manufacturing to **2216**. This utility allows you to set and change the password.

This function can be performed only if done immediately after switching the power on.

1. Select **2. Set Supervisory Password** from the System Management Utilities panel. The Set Supervisory Password panel is displayed (see Figure 8-8).
2. Type your new password and press **Enter**. You are prompted to enter your new password again.

**Note:** The supervisory password can consist of from 1 to 8 characters with no restrictions on which characters can be used.

```
Nways System Firmware
Version 1.0
(C) Copyright IBM Corporation, 1996 All Rights Reserved.
                        System Management Utilities

Select one:
 1. Set Power-On P+-----Set Supervisory Password-----+
 2. Set Supervisor |
 3. Enable Unatten | Type your new password, and then
 4. Disable Unatte | press Enter.
 5. Remove Power-0 |
 6. Remove Supervi | Enter - F1=Help - Esc=Quit
 7. Update System  | -----
 8. Display Error  |
 9. View or Set Vi+-----+
10. Manipulate Dead Man Timer
11. Remote Initial Program Load Setup
12. Change Management
13. Prepare Hard Disk
Enter - Esc=Quit - F1=Help -
-----
```

Figure 8-8. Set Supervisory Password Panel

3. Type the password again and press **Enter**.
4. The Password Saved panel is displayed with the message that your supervisory password has been saved.

## Enabling Unattended Start Mode

The default is that Unattended start mode is enabled. This causes the 2216 to load operational code automatically.

This function can be performed only if done immediately after switching the power on.

1. Select **3. Enable Unattended Start Mode** from the System Management Utilities panel. The Unattended Start Mode Changed panel is displayed (see Figure 8-9).
2. Press **Enter**.

```
Nways System Firmware
Version 1.0
(C) Copyright IBM Corporation, 1996 All Rights Reserved.
                        System Management Utilities

Select one:
 1. Set Power-On Password
 2. Set Supervisor+-----Unattended Start Mode Changed-----+
 3. Enable Unatten|
 4. Disable Unatte|   Unattended start mode has been
 5. Remove Power-0|   enabled.
 6. Remove Supervi|
 7. Update System  |   Enter  -
 8. Display Error  |   -----
 9. View or Set Vi+-----+
10. Manipulate Dead Man Timer
11. Remote Initial Program Load Setup
12. Change Management
13. Prepare Hard Disk

Enter  -   Esc=Quit  -   F1=Help  -
-----  -----  -----
```

Figure 8-9. Unattended Start Mode Changed (Enabled) Panel

**Note:** After you have enabled Unattended start mode, you can enter the firmware by pressing and holding **F1** at the terminal keyboard when the boot process begins.

## Disabling Unattended Start Mode

The default for the 2216 base firmware is that the Unattended start mode is enabled. You disable Unattended Start Mode using this utility.

**Note:** This function can be performed only if done immediately after switching the power on.

1. Select **4. Disable Unattended Start Mode** from the System Management Utilities panel. The Unattended Start Mode Changed panel is displayed (see Figure 8-10).
2. This panel informs you that the Unattended start mode has been disabled and prompts you to press **Enter**.

```
Nways System Firmware
Version 1.0
(C) Copyright IBM Corporation, 1996 All Rights Reserved.
                        System Management Utilities

Select one:
 1. Set Power-On Password
 2. Set Supervisory Password
 3. Enable Unatten+-----Unattended Start Mode Changed-----+
 4. Disable Unatte|
 5. Remove Power-0|         Unattended start mode has been
 6. Remove Supervi|         disabled.
 7. Update System
 8. Display Error   |         Enter  -
 9. View or Set Vi |         -----
10. Manipulate Dea+-----+
11. Remote Initial Program Load Setup
12. Change Management
13. Prepare Hard Disk

Enter  -   Esc=Quit  -   F1=Help  -
-----
```

Figure 8-10. Unattended Start Mode Changed (Disabled) Panel

## Removing the Supervisory Password

The use of a supervisory password allows you a degree of security by preventing unauthorized access to the 2216. However, removing the enforcement of the password could be a convenience while performing service.

**Note:** This function can be performed only if done immediately after switching the power on.

1. Select **6. Remove Supervisory Password** from the System Management Utilities panel.
2. The Remove Supervisory Password panel is displayed (see Figure 8-11).

```
Nways System Firmware
Version 1.0
(C) Copyright IBM Corporation, 1996 All Rights Reserved.
                        System Management Utilities

Select one:
 1. Set Power-On Password
 2. Set Supervisory Password
 3. Enable Unatten+-----Remove Supervisory Password-----+
 4. Disable Unatte|
 5. Remove Power-0| Do you want to remove the
 6. Remove Supervi| Supervisory password?
 7. Update System  |
 8. Display Error   | Yes - No -
 9. View or Set Vi | -----
10. Manipulate Dea+-----+
11. Remote Initial Program Load Setup
12. Change Management
13. Prepare Hard Disk

Enter - Esc=Quit - F1=Help -
-----
```

Figure 8-11. Remove Supervisory Password Panel

3. Select **Yes** if you want to remove the supervisory password. Press **Enter**.
4. The Password Removed panel is displayed. This panel informs you that the supervisory password has been removed.

## Updating System Firmware

Use this firmware utility to update the 2216 base firmware. Only full images of the firmware are shipped; therefore, when you select this option you completely replace the previous level of firmware.

1. Select **7. Update System Firmware** from the System Management Utilities panel.
2. The System Firmware Update panel is displayed (see Figure 8-12).

```
Nways System Firmware
Version 1.0
(C) Copyright IBM Corporation, 1996 All Rights Reserved.
                        System Management Utilities

Select one:
 1. Set Power-On Password
 2. Set Supervisory Password
 3. Enable Unattended Start Mode
 4. Disable Unattended Start Mode
 5. Remove Power-On+-----F/W Update Options-----+
 6. Remove Supervi
 7. Update System   1. TFTP a Remote Image File
 8. Display Error   2. XMODEM a Remote Image File
 9. View or Set Vi  3. Use a Local Image File
10. Manipulate Dea
11. Remote Initial  Enter - Esc=Quit - F-1=Help
12. Change Managem -----
13. Prepare Hard D+-----

Enter - Esc=Quit - F1=Help -
-----
```

Figure 8-12. System Firmware Update Panel

**Attention:** Do not power off the 2216 during the firmware update process. If the update fails, the 2216 will boot a backup firmware image. If this happens, repeat the update procedure to reload the onboard firmware image.

3. Select the option that you want to use from those listed. For TFTP, you will be prompted for a local (the “to”) and a remote (the “from”) file names that you want use (and the name of the server that can be reached by the 2216). In addition, you will be prompted to create a recovery image and a file name from which to update the firmware.

TFTP will not function with a slip interface.

The firmware update process begins. It informs you that the system firmware has been updated.

### Sample Steps for Installing New System Firmware Using Xmodem

Before starting this procedure, connect a terminal emulator to the 2216 (see “Access Methods” on page 7-1).

This is a two-part process. The firmware image is transferred to the 2216 and is then burned into the 2216 system flash.

1. From the F/W Update Options menu, select **2. XMODEM a Remote Image File**.



2. Type in the filename (for example, eptf5.ld) that you want to use for the temporary file that will be copied onto the C: drive of the 2216.

A message states to start the Xmodem transfer when the window is closed. This process is dependent on the terminal emulation package that you are using.

The transfer process is time-sensitive and may time out before the process starts. Restart from the F/W Update Options menu if necessary.

- If characters like '\$' appear by the message box, it means that the connection is not established.
- If 10-12 appears, Xmodem will likely time out and need to be restarted.

3. After Xmodem completes, a message similar to the following is displayed:

```
This selection will update your
system firmware. Do you want to
continue?
```

The system asks if you want to build a recovery block. It is optional, but recommended.

**Note:** Be patient, as the system writes from RAM to the hard drive. It may take up to 5 minutes.

4. After building a recovery block, additional messages will be displayed.

5. The system displays the file choices for firmware update. Choose the file that was just uploaded. The choices should look similar to those below:

```
( ) C:PRECOVER.IMG    03/20/97
(>) C:FIRM.LD        04/07/97
```

6. Answer **yes**, and the system updates the firmware.

**Note:** Do not switch the system off. The process erases the old firmware and copies the new firmware into flash memory. If the machine is powered off before the process is complete, you will need to reload the firmware from the recovery image.

7. A completed message appears when the firmware is updated.

## Displaying the Error Log

The error log is resident in NVRAM (not on the hard drive). See Appendix A, "Hardware Error Codes" on page A-1 to interpret the data that appears in the Error Code field.

1. Select **8. Display Error Log** from the System Management Utilities panel.
2. The Error Log panel is displayed (see Figure 8-13). See Appendix A, "Hardware Error Codes" on page A-1 for and explanation of the data that appears in the Error Codes field.

```
Nways System Firmware
Version 1.0
(C) Copyright IBM Corporation, 1996 All Rights Reserved.
                        System Management Utilities

Select one:
1. Set Power-On Password
2. Set Supervisory Password
3. Enable Unattended Start Mode
4. Disable Unattended Start Mode
5. Remove Power-On Password
+-----Event Log-----+
|
| 61. Src      1 08/src/arp/sysex/c200/io_int.c:324      00000005,012B
| 60. Bootup  0*****                                00-01, 21 01/03/96 16:23:27
| 59. Src      1 08/src/arp/sysex/c200/io_int.c:324      00000005,012B
|
|      Enter      -      Esc=Quit  -      F1=Help   -      F2=Clear Error Log -
|      -----      -----      -----      -----
|
+-----+
Enter - Esc=Quit - F1=Help -
-----
```

Figure 8-13. Error Log Panel

## Viewing or Setting Vital Product Data

This utility allows you to view vital product data (VPD) for the 2216. The system serial number is entered at the factory, but can be changed on the panel that appears after you select to view or set the VPD.

1. Select **9. View or Set Vital Product Data** from the System Management Utilities panel.
2. The View or Set Vital Product Data panel is displayed (see Figure 8-14). From this panel you can select the type of vital product data you want to view or set.

The serial number field and the model number field can be set under the "Hardware Vital Product Data" menu; Firmware Part Number is only viewable. Set the 2216-000 model number to correspond with the model number of device into which you have installed the system card.

```
Nways System Firmware
Version 1.0
(C) Copyright IBM Corporation, 1996 All Rights Reserved.
                        System Management Utilities

Select one:
 1. Set Power-On Password
 2. Set Supervisory Password
 3. Enable Unattended Start Mode
 4. Disable Unattended Start Mode
 5. Remove Power-On Password
 6. Remove Supervisory Password
 7. Update System Firmware +-----View or Set Vital Product Data-----+
 8. Display Error Log
 9. View or Set Vital Produc | Firmware Part Number
10. Manipulate Dead Man Time | Hardware Vital Product Data
11. Remote Initial Program L |
12. Change Management      | Enter - Esc=Quit - F1=Help -
13. Prepare Hard Disk      |
                             |-----+
Enter - Esc=Quit -
```

Figure 8-14. View or Set Vital Product Data Panel

3. For each selection, a View or Set Part Number panel is displayed that contains the part number you selected. Version number and dates are provided for the firmware and System Management Services.
4. If you want to view or change vital product data, select **Hardware Vital Product Data**.

5. The hardware VPD is stored in keyword format. The following is a list of the keywords and their meanings. Depending on the configuration of your system, not all of the keywords listed are necessarily present or have meaningful values.

- AT - Main logic card type
- DS - Text description of card
- FN - FRU number
- PN - Manufacturing part number
- ML - Maintenance level
- MF - Manufacturing location
- SN - Serial number
- BF - Boot flash level and ID
- NA - Burned-in MAC Address in ASCII Format
- ZB - Burned-in MAC Address in Hex Canonical Format
- TM - Machine type and model
- F# - Feature Number
- BS - Box serial number
- RC - Recycle count
- Z0 - Vendor ID

## Setting Up Remote Initial Program Load

This firmware utility allows you to:

- Load this minimum information to install this device in your network so that you can send it a configuration file or otherwise communicate with it.
  - Ping the 2216, after loading its minimum network parameters, to see if you can communicate with it.
  - Configure the PCMCIA LAN device on the Network Utility
1. Select **11. Remote Initial Program Load Setup** from the System Management Utilities panel.
  2. The “Network Parameters” panel is displayed (see Figure 8-15).

```
Nways System Firmware
Version 1.0
(C) Copyright IBM Corporation, 1996 All Rights Reserved.
System Management Utilities

Select one:
 1. Set Power-On Password +----- Network Parameters -----+
 2. Set Supervisory Password |
 3. Enable Unattended Start |           1. IP Parameters
 4. Disable Unattended Start |           2. Adapter Parameters
 5. Remove Power-On Password |           3. Ping
 6. Remove Supervisory Passw |
 7. Update System Firmware   |
 8. Display Error Log        |           Enter - Esc=Quit - F1=Help -
 9. View or Set Vital Produc |-----+
10. Manipulate Dead Man Time+-----+
11. Remote Initial Program Load Setup
12. Change Management
13. Prepare Hard Disk

Enter - Esc=Quit - F1=Help -
-----
```

Figure 8-15. Setup Remote Initial Program Load Panel

- If you select **IP Parameters**, a panel will be displayed on which you can enter:
  - Client IP Address (the IP address of the 2216)
  - Server IP Address
  - Gateway IP Address
  - Subnet Mask

An 2216 comes from the factory with the following default IP addresses:

<b>Client</b>	111.11.11.11
<b>Server</b>	111.11.11.10
<b>Gateway</b>	111.11.11.10
<b>Subnet mask</b>	255.255.255.0

3. The **Ping** option allows you to test connectivity.

## Manipulating the Dead Man Timer

This utility allows you to selectively enable or disable the dead man timer. The dead man timer has a granularity of 0.25 seconds and expires in 10 seconds. This tool would be useful in some troubleshooting procedures.

1. Select **10. Manipulate Dead Man Timer** from the System Management Utilities panel.
2. A Dead Man Timer Options panel is displayed. From this panel you can enable or disable the timer.

```
Nways System Firmware
Version 1.0
(C) Copyright IBM Corporation, 1996 All Rights Reserved.
                        System Management Utilities

Select one:
 1. Set Supervisory Password
 2. Enable Unattended Start Mode
 3. Disable Unattended Start Mode
 4. Remove Supervisory Password
 5. Update System Firmware
 6. Display Error Log
 7. View or Set Vital Product Data
 8. Copy Remote Files
 9. Remote Initial Program Load
10. Manipulate Dead Man Timer+-----Dead Man Timer Options-----+
11. Remote Initial Program
12. Change Management
13. Prepare Hard Disk

Enter - Esc=Quit -      1. Enable Dead Man Timer
                        2. Disable Dead Man Timer
-----              Enter - Esc=Quit - F1=Help -
+-----+-----+-----+-----+-----+-----+-----+-----+-----+
+-----+-----+-----+-----+-----+-----+-----+-----+-----+
```

Figure 8-16. Manipulate Dead Man Timer Panel

## Change Management

Change Management enables you to manipulate the level of software code that will run on the 2216. (Appendix D, “Managing Operational Code and Configuration Files” on page D-1 has additional information about change management).

### Xmodem Software Selection

The Xmodem protocol is supported only from the “System Management Services” menu. To access the “System Management Services” menu, you have to either interrupt the boot-up sequence or bring up the 2216 in Attended mode. The Change Management command is available from the “System Management Utilities” option of the Main Menu. From that point, the 2216 will direct you as to what to transfer in and where to put the image.

**Notes:**

1. When the 2216 is in firmware mode, there is no active configuration or image. Therefore, you should use caution when specifying where to write new images or configurations.
2. When using Xmodem to transfer a multiple load module image (used in Release 2 in the form of several files ending in .ld), **you must** transfer each of the modules (.ld files) one by one to get the entire load module image.

When an entire load image has transferred, the status of the bank will change from CORRUPT to AVAIL. Transfer file LML.ld first. Unless you see an information message ERROR WRITING FILE appear, assume each individual transfer has been successful.

When you are finished with file transfer, select **List software** on the Change Management menu. The status will have changed to AVAIL for that bank that has the new load image.

The following sample menus are associated with Xmodem download. These menus show the text that is displayed when you choose Change Management.

**1. Examples:**

```
Nways System Firmware
Version 1.0
(C) Copyright IBM Corporation, 1996 All Rights Reserved.

                                Change Management Software Control

Select one:
1. Add Description Data
2. Describe Software
3. Control Rebooting of Router
4. Control Dumping of Router
5. Copy Software
6. Erase Software
7. List Software
8. Lock Config File
9. Set Boot Information
10. TFTP Software
11. Unlock Config File
12. XMODEM Software

Enter   -   Esc=Quit -   F1=Help  -
-----  -   -       -   -       -
```

2. Select **12. XMODEM Software**.

```

Nways System Firmware
Version 1.0
(C) Copyright IBM Corporation, 1996 All Rights Reserved.

Change Management Software Control

```

- ```

1. Add Description Data
2. Describe Software
3. Control Rebooting of Router
4. Control Dumping +-----Select Type-----+
5. Copy Software
6. Erase Software
7. List Software
8. Lock Config File
9. Set Boot Informa
10. TFTP Software
11. Unlock Config Fi+-----+
12. XMODEM Software

```

```

1. Config
2. Load Image
Enter - Esc=Quit - F1=Help -
-----

```

```

Enter - Esc=Quit - F1=Help -
-----

```

3. Select either **Config** (for configuration file) or **Load Image** (for the operational software file).

The following figure is an example of the Load Image selection.

```

Nways System Firmware
Version 1.0
(C) Copyright IBM Corporation, 1996 All Rights Reserved.
System Management Utilities

2216 Software Control
+-----+-----+-----+
| BANK A | | Description | | Date |
+-----+-----+-----+
IMAGE - AVAIL				-14256 Jan 1970 -
CONFIG 1 - PENDING				-14256 Jan 1970 -
CONFIG 2 - NONE				-14256 Jan 1970 -
CONFIG 3 - NONE				-14256 Jan 1970 -
CONFIG 4 - NONE				-14256 Jan 1970 -
+-----+-----+-----+				
BANK B		Description		Date
+-----+-----+-----+				
IMAGE - PENDING				-14256 Jan 1970 -
CONFIG 1 - NONE				02 Jan 1994 20:39
CONFIG 2 - NONE				02 Jan 1994 20:41
CONFIG 3 - NONE				1994 20:43
CONFIG 4 - NONE				1994 20:45
+-----+-----+-----+
* - Last Used Config L - Config F
12. XMODEM Software
Enter - Esc=Quit - F1=Help -
-----
1. Bank A Enter
2. Bank B Esc=Quit
F1=Help
-----

```

The following figure is an example of the Config selection.



Nways System Firmware  
Version 1.0  
(C) Copyright IBM Corporation, 1996 All Rights Reserved.  
System Management Utilities

2216 Software Control

| BANK A             | BANK B          |
|--------------------|-----------------|
| IMAGE - PENDING    | IMAGE - AVAIL   |
| CONFIG 1 - PENDING | CONFIG 1 - NONE |
| CONFIG 2 - NONE    | CONFIG 2 - NONE |
| CONFIG 3 - NONE    | CONFIG 3 - NONE |
| CONFIG 4 - NONE    | CONFIG 4 - NONE |

XMODEM Software

+Select Destination Config+

|          |         |
|----------|---------|
| Config 1 | Enter - |
| Config 2 | -----   |
| Config 3 | -----   |
| Config 4 | -----   |
|          | -----   |

Enter - Esc=Quit - F1=Help -



---

## Chapter 9. Using Operational Diagnostics

This chapter describes general procedures for invoking 2216 base operational diagnostics and includes sample screens. 2216 base operational diagnostics are the same on the 2216 Model 400 or Network Utility.

Operational diagnostics for the 2216 Model 400 or Network Utility can be invoked through the command line interface. You can invoke the 2216 base operational diagnostics using the local terminal connection or from the Support Center using a remote connection.

If the 2216 Model 400 or Network Utility is not configured (booted up and in config-only mode), operational diagnostics cannot be invoked.

---

### Overview of Diagnostic Functions and Status Information

Diagnostics are available to test each adapter. In some cases, you may also be able to test individual ports of multi-port adapters. These tests execute concurrently with normal operation on other adapters and ports.

You can use the following types of diagnostic pages:

- **Device List** to show a summary list of devices.
- **Device Status and Control** to allow you to disable and test a device
- **Test Results** to present the results of the test for a device.
- **Test Options** to allow you to choose specific testing options for a device.
- **Setup for Loop Test** to prompt for the presence of diagnostic aids such as wrap plugs.
- The **Restore from Loop Test** to prompt you to remove diagnostic aids that have been installed prior to testing.

Many of the diagnostic pages have help information that provides definitions of the status fields and testing options.

These diagnostics operate in a multi-tasking environment that allows several diagnostic processes to be active at the same time. The Diagnostic Control Program controls which test processes are active and which one has access to the user interface.

When you make a selection from the Device Status and Control Page for a device, a separate testing process is started that runs independently of the other diagnostic menus. You can then go back to the Device List page or exit the diagnostic menus, returning later to view the results of the test.

When an active test process wants to report results or obtain information from you, the diagnostic status for the device will change to MESSAGE. When you select the device on the Device List page, the testing process will be given access to the console interface and the message will be displayed.

**Note:** It is necessary to “refresh” the Device List and Device Status and Control pages in order to see the changing status of active test processes.

---

## Using the Command Line Interface Operational Diagnostics

The following example shows how to access the 2216 base diagnostics through the command line interface:

1. At the asterisk (\*), type **diags** and press **Enter**.
2. The Diagnostic Menu appears (Figure 9-1 ). To make your selection, type in the number of your choice and press **Enter**.

```
DIAGNOSTIC MENU

Select from the following list of functions:

<1. The Device List Page>
  shows operational and diagnostic status for each of the installed devices.
  From this page you can also link to the Device Status and Control page
  for each adapter.

<2. The Diagnostic Test History Log>
  contains a summary of recent diagnostic testing activity.

<3. The Diagnostic Error Log>
  contains error information for recent diagnostic tests that have
  detected errors.

First time users should review the <4.Introduction> to using the diagnostics.

Select (1-4 or E=Exit Diagnostics):
```

*Figure 9-1. Operational Diagnostics Main Menu*

3. Select **<1. The Device List Page>** to view a list of installed devices. (Status and test options for each device are from the Device List page.) The Device Status and Control panel (similar to the one in Figure 9-2 on page 9-3) appears.

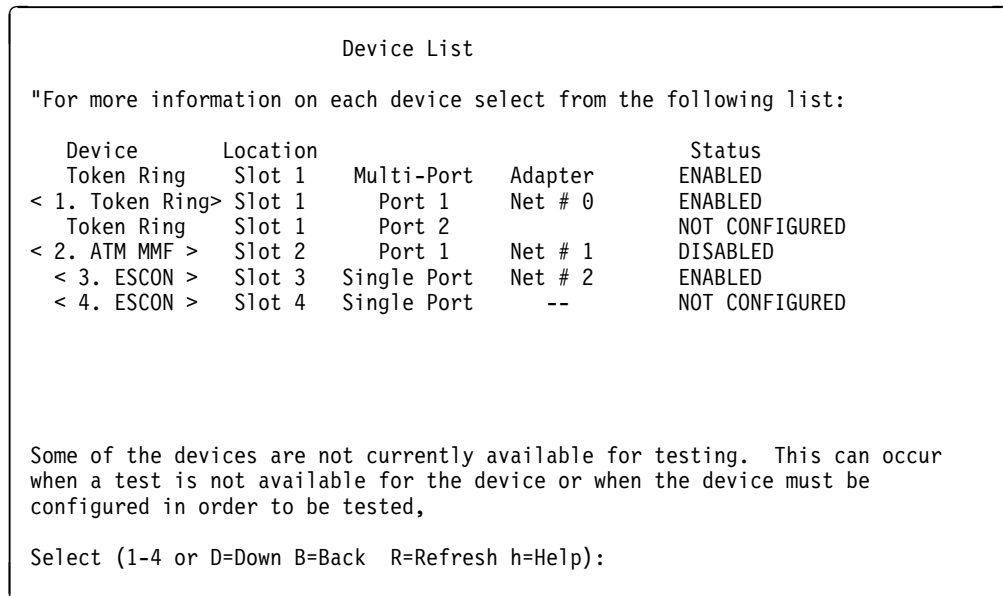

Figure 9-2. Sample of Device List Panel Showing Interfaces

The Device List is the starting point for running a test. It also provides a check to determine if all of the installed devices are being recognized.

The Device List includes a summary status for each device. The devices that are testable or that have additional status available can be selected. Selecting a device will then display the Device Status and Control page for that device.

The Status displayed for a device may have the same states as "Operational Status" which is listed on page 4 on page 9-4. It can also include be any of the following values:

**MESSAGE** Select the device to view and respond to the message.

**TESTING** The device is being tested.

- If you select the ATM interface (<2. **ATM MMF**> on the Device List panel), the Device Status and Control panel for the ATM adapter appears (Figure 9-3 on page 9-4).

```

Device Status and Control

155Mb/s ATM over multi-mode fiber, Slot 2,- Net # 1

Operational Status   Diagnostic Status   Fault Status   Network Connection
DISABLED             ACTIVE             OK             UP

Select from the following:
  Disable Device
<1. Enable Device >
<2. Run Default Test >
<3. Run Interactive test >
<4. Loop Test - stop on first error >
<5. Loop Test - Log all errors >
  Stop Test
<6. View Hardware Test Log >
<7. View Hardware Error Log >

-----

Select (1-7 or B=Back R=Refresh H=Help):

```

Figure 9-3. Device Status and Control Panel (Device Disabled)

The Device Status and Control Page displays status and a menu of actions for the selected device. The status fields that are displayed are dependent on the characteristics of the device.

The menu items that are active on the Device Status and Control panel are dynamically determined depending on the state of the device (that is, whether it is enabled, disabled, or testing).

In this example, the device is disabled. The Enable Device choice and all of the choices to start a test are active and can be selected. If the device were enabled, it would need to be disabled before testing.

- When the Device Status and Control panel is displayed (and the status for the device is ENABLED), you can disable the device by selecting the Disable option.
- When testing is complete, the device can be enabled using the diagnostic menus or using the router's **talk 5** commands.
- After the message: Diagnostic Test for **adapter\_x** has status available appears, select **Refresh** to show the status information for a device.

The status fields which are displayed for most devices have the following meanings:

- **Operational Status**

|                 |                                                                                                                  |
|-----------------|------------------------------------------------------------------------------------------------------------------|
| ENABLED         | The device is enabled for normal operation. For multi-port devices this means that at least one port is enabled. |
| ENABLED PENDING | Waiting for completion of Enable request.                                                                        |
| See Note        | The device is in a <i>special state</i> that is explained on the Page.                                           |

|                 |                                                                                                                                 |
|-----------------|---------------------------------------------------------------------------------------------------------------------------------|
| DISABLED        | The device is Disabled. Diagnostic testing can now be performed. For multi-port Devices this means that all ports are disabled. |
| DISABLE PENDING | Waiting for completion of Disable request.                                                                                      |
| DIAGNOSTICS     | A configured device is being used by the diagnostics.                                                                           |
| NOT CONFIGURED  | The device is not configured for normal operation.                                                                              |
| MIS CONFIGURED  | The configuration does not match the physical device.                                                                           |
| HARDWARE ERROR  | A hardware error has been detected that prevents further use of the device.                                                     |

- **Diagnostic Status**

|                  |                                                                                                  |
|------------------|--------------------------------------------------------------------------------------------------|
| INACTIVE         | Diagnostic for the device is not running.                                                        |
| TESTING          | A testing process for the device is active and the device is being tested.                       |
| LOOP AND LOG     | A testing process for the device is active and will loop and log any errors until stopped.       |
| LOOP UNTIL ERROR | A testing process for the device is active and will loop until an error occurs or it is stopped. |
| MESSAGE          | A testing process for the device is active and it is waiting for user input.                     |

- **Fault Status**

|              |                                                                                                                                                                                                                                                                                                |
|--------------|------------------------------------------------------------------------------------------------------------------------------------------------------------------------------------------------------------------------------------------------------------------------------------------------|
| OK           | The last test of the device completed without error.                                                                                                                                                                                                                                           |
| ISOLATED     | A hardware failure has been detected and isolated to the device.                                                                                                                                                                                                                               |
| NON-ISOLATED | A problem has been detected, but the failure may be external to the device. This most often occurs with network adapters that have external cables, modems, or LAN connections. Running a diagnostic of the adapter with a wrap plug attached can usually determine if the adapter has failed. |
| UNKNOWN      | No test results are currently available for the device.                                                                                                                                                                                                                                        |

- **Network Status**

|         |                                                                       |
|---------|-----------------------------------------------------------------------|
| UP      | The network connection is established.                                |
| DOWN    | A network connection cannot be detected.                              |
| TESTING | The router is attempting to determine if a network connection exists. |

UNKNOWN The state of a network connection cannot be determined at this time.

N/A Network Status does not apply to this device.

### ***Explanation of menu choices***

While all of the menu choices are displayed for each device, only those that are appropriate for the current state of the device will be active for a selection.

#### **Enable Device**

The device will be enabled for normal operation. This performs the same function as the **enable** or **test** commands available at the router's monitoring (talk 5) prompt (+).

#### **Disable Device**

The device is taken out of its normal operational state. If this menu option is available, then the device must be disabled before any diagnostic test can be started. This performs the same function as the **disable** command available at the router's monitoring (talk 5) console.

#### **Run Default Test**

This starts a test which assumes that the device is set up for normal operation. For communication adapters this means that it has a cable attached and is connected to the network.

#### **Run Interactive Test**

This starts a test which will present an additional menu of options such as cable attachment and wrap plugs can be specified.

#### **Stop Test**

Stops a looping test. Depending on the length of each test loop, this could take up to a minute.

#### **Loop Test - stop on first error**

This starts a looping test that will stop when the first error is detected. A menu of additional test options may be presented before the loop is started.

#### **Loop Test - Log all errors**

This starts a looping test that will loop until a \"Stop Test\" request is made. All detected errors are logged. A menu of additional test options may be presented before the loop is started.

#### **View Test History Log**

Displays a history of recent diagnostic tests that have been executed.

#### **View Hardware Error Log**

Displays a list of errors detected by diagnostic tests.

5. Type **E** and press **Enter** to exit the diagnostic menus and return to the command line interface prompt (\*).



## Testing the Adapters

These tests for the adapters help to determine whether or not the adapter is functioning correctly. Most of the adapters (for example, the EIA 232, X.21, V.35/36, ESCON, and HSSI) contain basic testing functions; however, other adapters may have additional tests such as wrap plug and cable tests. The ESCON adapter also has optical power (page 9-14) and light reception tests (page 9-10).

Complete the following steps to test a faulty (or newly installed) adapter:

- Power on the 2216 Model 400, or plug in the power cord on the Model TX1 or TN1.
- Run diagnostics on the new adapter (page 9-8)
- If you have an ESCON adapter, run the light test on the new fiber optic cable (page 9-10).

Refer to “Overview of Diagnostic Functions and Status Information” on page 9-1 for additional information on the use of 2216 base operational diagnostics.

## Powering On the IBM 2216

1. Power on the 2216 Model 400, or plug in the power cord on the Model TX1 or TN1. Messages equivalent to the following appear on the TTY console after you apply power to the 2216 Model 400 or Network Utility.

```

PRESENCE_MGR> LIC280 detected in slot 1
PRESENCE_MGR> LIC287 detected in slot 3
PRESENCE_MGR> LIC287 detected in slot 4

Please press the space bar to obtain the console.

Disk Load: Using bank B and config number 3

```

2. Press the space bar.

```

Console granted to this interface

*

```

**Note:** The operator interface described in this chapter is the *Command Line Interface*, also known as the *Operator Control Module (OPCON)*. This interface appears when you Telnet into the service port of the 2216 or when you attach an ASCII terminal emulator to the service port either remotely or locally.

### Running Diagnostics on the Adapter

The following is a *sample sequence* with sample screens for running the diagnostics. The selections that you see during your test may be different.

Before running the test, disable the adapter (see “Suspending Traffic on an Adapter Port” on page F-7).

1. At the OPCODE (\*) prompt, type **diags** and press **Enter**.
2. The Diagnostic Menu (see Figure 9-1 on page 9-2) appears. To make a selection, type in the number of your choice and press **Enter**.
3. Type **1** and press **Enter** to access the Device List Page.
4. Select a device to test (for example, type **4** for ESCON) to test the ESCON channel adapter in slot 4.
5. Select **Run Interactive Test**. The Test Options menu appears:

```

                                     Test Options
                                     Screen 1 of 1

LIC 287 - ESCON Channel Adapter, Slot 4

Operational Status  Diagnostic Status  Fault Status  Network Connection
NOT CONFIGURED      MESSAGE          UNKNOWN      UNKNOWN

Do not remove this device while testing.
Select one of the following test options:
* < 1. Run all tests excluding external wrap test >
* < 2. Run all tests including external wrap test >
  Individual tests:
* < 3. PCI BUS >
* < 4. PROCESSOR >
* < 5. MEMORY >
* < 6. MEMORY PROT >
* < 7. TIMER >
* < 8. AIB >
* < 9. WRAP PLUG >
* <10. OPTICAL POWER >
* <11. LIGHT RECEPTION >

Select (1-11 or B=Back R=Refresh H=Help ):2
```

6. Type **2** and press **Enter** to run all tests including external wrap test. The following panel appears:

```

                                     Setup For Wrap Test
                                     Screen 1 of 1

LIC 287 - ESCON Channel Adapter, Slot 4

Operational Status  Diagnostic Status  Fault Status  Network Connection
NOT CONFIGURED      TESTING          UNKNOWN      UNKNOWN

Do not remove this device while testing.

Install the wrap plug (PN 5605670) on the ESCON adapter located in slot 4

Confirm that the wrap plug is installed.
< 1. Start test. >

Select (1 or B=Back R=Refresh H=Help ):1
```

- Label and disconnect the cable for the adapter. Attach the wrap plug. Type **1** and press **Enter** to start the test.

This is a long-running test. The Device Status and Control Menu is displayed again. Note that the Diagnostic Status is TESTING. This indicates that the tests are running and will take about 3 minutes to complete.

```

                                     Screen 1 of 1
                               Device Status and Control Menu

LIC 287 - ESCON Channel Adapter, Slot 4

Operational Status  Diagnostic Status  Fault Status  Network Connection
  NOT CONFIGURED      TESTING          UNKNOWN       UNKNOWN

Do not remove this device while testing.

Select from the following:
  Disable Device
  Enable Device
  Run Default Test
  Run Interactive Test
  Loop Test - stop on first error
  Loop Test - Log all errors
  Stop Looping Test
  < 1. View Test History Log >
  < 2. View Hardware Error Log >

Select (1-2 or  B=Back R=Refresh H=Help ):r

```

- Wait until a message similar to the following is displayed: Diagnostic Test for ESCON has status available
- Type **r** and press **Enter** to refresh the display. The diagnostic Status changes from TESTING to MESSAGE. At this point, the following panel is displayed:

```

                                     Screen 1 of 1
                               Restore From Wrap Test

LIC 287 - ESCON Channel Adapter, Slot 4

Operational Status  Diagnostic Status  Fault Status  Network Connection
  NOT CONFIGURED      MESSAGE          UNKNOWN       UNKNOWN

Do not remove this device while testing.

Remove the wrap plug on the ESCON adapter located in slot 4.

Reattach the fiber connection.

Select Back to see the results of the test.
Select ( B=Back R=Refresh H=Help ):b

```

- Remove the wrap plug.
- Reconnect the network cable to the adapter.
- Select **b** to view the results of the test. In this example, the system reports test completion with No Errors. If the test fails, you will receive a message directing further action.

## ESCON-only Tests

```

                                     Test Results
                                     Screen 1 of 1

LIC 287 - ESCON Channel Adapter, Slot 4

Operational Status  Diagnostic Status  Fault Status  Network Connection
NOT CONFIGURED      INACTIVE      OK            UNKNOWN

The Test Completed with No Errors.

Select ( B=Back ): b
```

13. Select **b** to return to the Device Status and Controls Menu.

---

## ESCON-only Tests

### Run the Light Test on the New Fiber Optic Cable

After you have run diagnostics on the new ESCON adapter and verified that it is functioning correctly, you can test that the fiber optic cable is connected correctly and transmitting light to the adapter.

1. From the Device Status and Controls Menu, select Run Interactive Test to display the Test Options panel.

```

                                     Test Options
                                     Screen 1 of 1

LIC 287 - ESCON Channel Adapter, Slot 4

Operational Status  Diagnostic Status  Fault Status  Network Connection
NOT CONFIGURED      MESSAGE          OK            UNKNOWN

Do not remove this device while testing.
Select one of the following test options:
* < 1. Run all tests excluding external wrap test >
* < 2. Run all tests including external wrap test >
  Individual tests:
* < 3. PCI BUS >
* < 4. PROCESSOR >
* < 5. MEMORY >
* < 6. MEMORY PROT >
* < 7. TIMER >
* < 8. AIB >
* < 9. WRAP PLUG >
* <10. OPTICAL POWER >
* <11. LIGHT RECEPTION >

Select (1-11 or B=Back R=Refresh H=Help ):11
```

2. Enter **11** on the Test Options Panel to run the light reception test. At this point, the following panel appears.

```

                                Screen 1 of 1
                                Setup For Light Reception Test
LIC 287 - ESCON Channel Adapter, Slot 4, Net # 0
Operational Status  Diagnostic Status  Fault Status  Network Connection
      NOT CONFIGURED      TESTING           OK             UNKNOWN

First, be sure that you have successfully run the Wrap Plug Test on slot 4.

Then, remove the wrap plug from the ESCON adapter
(if still installed).

Connect the fiber for an operational ESCON channel to the adapter located in
slot 4.

Confirm that the correct fiber is installed.
< 1. Start test. >

Select (1 or B=Back R=Refresh H=Help ):1

```

3. Install the fiber, then enter **1** to start the test. Because this is a “long running test,” the Device Status and Control Menu will be displayed again. Notice that the Diagnostic Status is TESTING. This indicates that the test is now running and will take about 20 seconds to complete.

```

                                Screen 1 of 1
                                Device Status and Control Menu
LIC 287 - ESCON Channel Adapter, Slot 4, Net # 0
Operational Status  Diagnostic Status  Fault Status  Network Connection
      NOT CONFIGURED      TESTING           OK             UNKNOWN

Do not remove this device while testing.

Select from the following:
  Disable Device
  Enable Device
  Run Default Test
  Run Interactive Test
  Loop Test - stop on first error
  Loop Test - Log all errors
  Stop Looping Test
  < 1. View Test History Log >
  < 2. View Hardware Error Log >

Select (1-2 or B=Back R=Refresh H=Help ):r

```

4. After the message Diagnostic Test for **adapter x** has status available appears, select **Refresh** to show the status information for a device. At this point, the following panel is displayed.

## ESCON-only Tests

```
Screen 1 of 1
Restore From Light Reception Test
LIC 287 - ESCON Channel Adapter, Slot 4, Net # 0
Operational Status Diagnostic Status Fault Status Network Connection
NOT CONFIGURED MESSAGE OK UNKNOWN
Do not remove this device while testing.
Leave the fiber connected to the ESCON adapter located in slot 4
if it is the fiber intended for this adapter.
If it is not the fiber intended for this adapter,
connect the correct fiber now.
Select Back to see the results of the test.

Select ( B=Back R=Refresh H=Help ):b
```

- Typically, you do not need to do anything here. If you are testing cables, this simply tells you that the test has completed and that you should ensure that the correct fiber is connected.
- Select **b** to see the results of the test.

```
Screen 1 of 1
Test Results
LIC 287 - ESCON Channel Adapter, Slot 4, Net # 0
Operational Status Diagnostic Status Fault Status Network Connection
NOT CONFIGURED INACTIVE OK UNKNOWN
The Test Completed with No Errors.

Select ( B=Back ):
```

If the test completed with no errors, light was detected on the fiber optic cable.

```

                                Screen 1 of 1
                                Test Results

LIC 287 - ESCON Channel Adapter, Slot 4, Net # 0

Operational Status  Diagnostic Status  Fault Status  Network Connection
      NOT CONFIGURED      INACTIVE      NON-ISOLATED      UNKNOWN

No light is being detected on the ESCON adapter in slot 4. Ensure that the
ESCON fiber is connected to an ESCON director or an ESCON channel.

Select ( B=Back ):e
    
```

If light was not detected, an error message is displayed, indicating that the fiber and its connections need to be rechecked.

## ESCON Interactive Test Options

The Test Options menu is displayed in response to a Run Interactive Test request on the Device Status and Control Menu. Both test suites and individual tests are available to allow you to examine the entire adapter or isolate its various components.

```

                                Screen 1 of 1
                                Test Options

LIC 287 - ESCON Channel Adapter, Slot 4, Net # 0

Operational Status  Diagnostic Status  Fault Status  Network Connection
      DISABLED      MESSAGE      UNKNOWN      UNKNOWN

Do not remove this device while testing.
Select one of the following test options:
* < 1. Run all tests excluding external wrap test >
* < 2. Run all tests including external wrap test >
  Individual tests:
* < 3. PCI BUS >
* < 4. PROCESSOR >
* < 5. MEMORY >
* < 6. MEMORY PROT >
* < 7. TIMER >
* < 8. AIB >
* < 9. WRAP PLUG >
* <10. OPTICAL POWER >
* <11. LIGHT RECEPTION >

Select (1-11 or B=Back R=Refresh H=Help ):
    
```

Option 1 on the Test Options menu runs tests 3 through 8. Option 2 runs the first test set and the wrap test. The remaining options, 3 to 11, enable the execution of tests individually.

If you select option 3, 4, 6, or 7, the results will be displayed immediately.

## ESCON-only Tests

If you select test option 1, 2, 5, 8, 9, or 11 (all long-running tests) the result may not be available for a few minutes. In this case, the test will continue to run and the Device Status and Control Menu will be displayed again.

If you select option 1, 2, 5, 8, 9, or 11, you will also notice that the Operational Status field indicates "TESTING." In these instances, you will need to refresh the panel until the system displays your test results. Option 10 is also a long-running test, but selection of this option does not invoke the Device Status and Control Menu. Instead, the system displays a panel that allows you to end the test at your convenience.

The individual tests are the same tests that run as part of the default tests. However, there are a few additional tests that are available only from the Test Options menu. They are:

### Wrap plug

Option 9 runs the AIB test unit and an optical (external) wrap test. The wrap test requires that the fiber be removed and a wrap plug be installed. For an example of using this function, see "Testing the Adapters" on page 9-7.

### Optical power

Option 10 runs the AIB test unit and allows you to measure the optical output of the adapter. This test requires that the fiber be removed and an optical power meter be attached. See "ESCON Optical Power Measurement Test" for additional information.

### Light reception

Option 11 runs the AIB test unit and also tests whether the attached fiber is transmitting light. This test can be used to determine if the remote end of the fiber is connected. For an example of using this function, see "Testing the Adapters" on page 9-7.

## ESCON Optical Power Measurement Test

The following example describes the use of option **10**, Optical Power.

Enter **10** on the Test Options panel to run the optical power meter test.

```
Test Options                                     Screen 1 of 1
LIC 287 - ESCON Channel Adapter, Slot 4, Net # 0
Operational Status  Diagnostic Status  Fault Status  Network Connection
DISABLED           MESSAGE           UNKNOWN      UNKNOWN

Do not remove this device while testing.
Select one of the following test options:
* < 1. Run all tests excluding external wrap test >
* < 2. Run all tests including external wrap test >
  Individual tests:
* < 3. PCI BUS >
* < 4. PROCESSOR >
* < 5. MEMORY >
* < 6. MEMORY PROT >
* < 7. TIMER >
* < 8. AIB >
* < 9. WRAP PLUG >
* <10. OPTICAL POWER >
* <11. LIGHT RECEPTION >

Select (1-11 or B=Back R=Refresh H=Help ):10
```



The optical power measurement test verifies that the ESCON channel adapter in the slot indicated is operating correctly and that the receive input level is within tolerance.

This test assumes that you have the following equipment installed:

- Optical Power Meter
- Duplex-to-Duplex Coupler
- Duplex-to-Biconic Test Cable

If you do not have the correct equipment, or wish to bypass this test, reinstall the fiber (if you removed it) and select **B** to return.

Using the materials previously listed to complete the test, perform the following steps:

1. Ensure that the black cap is over the biconic receptacle at the top of the power meter.
2. Press power On/Off. AUTO OFF appears on the display.
3. Allow a 2-minute warmup. The meter turns off if you do not press a button within 10 minutes.
4. If the meter does not display **Optical Power Meter**, repeatedly press the lambda pushbutton until 1300 nm appears.

**Note:** To ensure that the pushbutton produces the desired results, do not hold down the pushbutton for more than half a second.

5. Press Zero. The following two displays appear:

- A value between 0.30 and 0.70 nanowatts (nW)
- After a short time **0** blinks, indicating that the meter is correctly zeroed.

If the meter is not correctly zeroed, a Hi or Lo is displayed after you press Zero. Press Zero again, and using a jeweler's screwdriver, adjust the trim pot that is beside the biconic receptacle at the top of the meter until a value between 0.30 and 0.70 nW is displayed. Set the value to 0.50, if possible.

6. Press Zero again to zero the meter.

The meter must also display dBm. If nW is displayed, press dBm/Watt. The optical power meter is now set.

7. After you set the meter, connect the black biconic connector of the test cable to the biconic receptacle on top of the power meter.
8. Enter **1** to start the test as indicated in the following example.

```

                                Setup For Optical Test                                Screen 1 of 1
LIC 287 - ESCON Channel Adapter, Slot 4, Net # 0
Operational Status  Diagnostic Status  Fault Status  Network Connection
DISABLED            TESTING           UNKNOWN      UNKNOWN
Do not remove this device while testing.
Install the duplex-to-biconic test cable connector to the ESCON
channel adapter located in slot 4.
Set the optical power meter to the following options:
* -- Power turned on
* -- Set for 1300 nanometers (nm)
* -- Zeroed
* -- The decibel scale displayed (dBm)
Confirm the meter is set.
< 1. Start > the adapter transmitter.
Select (1 or  B=Back R=Refresh H=Help ):1

```

The green port LED on the 2216 base ESCON Adapter will start blinking once the adapter has started transmitting the idle sequences. At this point, record the signal level displayed on the power meter. A correctly functioning 2216 base ESCON adapter should have a power level of -21.0 dBm or more (for example, -18.0 dBm).

9. Replace the ESCON Channel Adapter if its power level is too low.
10. Enter 1 from the Optical Test in Progress panel to Stop the test.

```

                                Optical Test In Progress                                Screen 1 of 1
LIC 287 - ESCON Channel Adapter, Slot 4, Net # 0
Operational Status  Diagnostic Status  Fault Status  Network Connection
DISABLED            TESTING           UNKNOWN      UNKNOWN
Do not remove this device while testing.
The green PORT LED should now be flashing on the ESCON channel
adapter in slot 4, indicating that it is transmitting IDLE sequences.
You may now record the power level displayed on the optical power meter
A properly functioning ESCON should have a power level of -21.0dBm or more
(for example -18.0dBm).
Select < 1. Stop > test when you have finished
measuring the signal level.
Select (1 or  B=Back R=Refresh H=Help ): 1

```

11. The following Test Results panel is displayed when you stop the test.

Test Results

LIC 287 - ESCON Channel Adapter, Slot 4, Net # 0

| Operational Status | Diagnostic Status | Fault Status | Network Connection |
|--------------------|-------------------|--------------|--------------------|
| DISABLED           | INACTIVE          | OK           | UNKNOWN            |

The Test Completed with No Errors.

Select ( B=Back ):

## ESCON-only Tests

## Appendix A. Hardware Error Codes

The error log that is displayed when you use the Displaying the Error Log firmware utility (see “Displaying the Error Log” on page 8-16) contains error codes. This appendix contains explanations for those error codes.

| Error Code | Physical Location | Software Subsystem | Explanation                                                                                                                         |
|------------|-------------------|--------------------|-------------------------------------------------------------------------------------------------------------------------------------|
| 00010000   | Processor         | Processor          | Processor test failure                                                                                                              |
| 00011000   | PPC Board         | NVRAM              | 128-KB Non-volatile RAM test failure                                                                                                |
| 00015001   | PPC Board         | Flash              | An error occurred while erasing the system firmware.                                                                                |
| 00015002   | PPC Board         | Flash              | An error occurred while updating the system firmware.                                                                               |
| 00015500   | PPC Board         | Interrupts         | PPC board interrupt test failure.                                                                                                   |
| 00015501   | PPC Board         | Interrupts         | Interrupt test of the processor's timing register failed.                                                                           |
| 00015502   | PPC Board         | Interrupts         | Interrupt test of the PPC board clock failed.                                                                                       |
| 00015503   | PPC Board         | Interrupts         | Interrupt test of the PPC board programmable timer failed.                                                                          |
| 00016002   | PPC Board         | RTC-NVRAM          | Read/Write test failure for PPC board clock.                                                                                        |
| 00017001   | PPC Board         | Security           | CMOS battery drained. Replace RTC/8KB NVRAM.                                                                                        |
| 00017002   | PPC Board         | Security           | CMOS Error—data is gone. Replace RTC/8KB NVRAM.                                                                                     |
| 00017003   | PPC Board         | Security           | Power Interruption during last boot sequence update.                                                                                |
| 00017007   | PPC Board         | Security           | Maximum unsuccessful attempts to enter password was reached. Time and date are logged.                                              |
| 00020000   | Memory            | Memory             | Memory test error; run further tests.                                                                                               |
| 000210y0   | DIMM slot y       | Memory             | Memory error with DIMM slot y (where y=1 or 2); <i>Excluding</i> System Card FRU PN 85H7916 or 30L5820. See Figure 5-1 on page 5-9. |
| 01291000   | L2 Cache          | L2 Cache           | For later release                                                                                                                   |
| 1msceddd   | PPC Board         | Octal Uart         | Octal Uart error.                                                                                                                   |
| 2msceddd   | PPC Board         | I <sup>2</sup> C   | I <sup>2</sup> C controller, bus, or device error                                                                                   |
| 3msceddd   | PPC Board         | GCOM               | GCOM controller error                                                                                                               |
| 30002000   | System Card       | —                  | Hard disk error. Format hard disk.                                                                                                  |
| 5msceddd   | PPC Board         | PCMCIA             | PCMCIA controller error                                                                                                             |
| 50000000   | PPC Board         | PCMCIA             | PCMCIA controller error                                                                                                             |
| 80001300   | —                 | Flash              | Firmware update file is at the same level as current firmware. Update canceled.                                                     |
| 80001400   | —                 | Flash              | Firmware update file does not support this system. Update canceled.                                                                 |
| 80001500   | —                 | Flash              | The firmware update file is corrupted. Update canceled.                                                                             |
| 80001600   | —                 | Flash              | The firmware update file is corrupted. Update canceled.                                                                             |
| 80001700   | —                 | Flash              | See 80001500.                                                                                                                       |
| 80001700   | —                 | Flash              | See 80001500.                                                                                                                       |
| 80001800   | —                 | Flash              | A valid firmware update file cannot be located. Update canceled.                                                                    |
| 80001900   | —                 | Flash              | See 80001500.                                                                                                                       |
| 80002100   | —                 | Flash              | The firmware update file cannot be loaded. Update canceled.                                                                         |
| 80002400   | —                 | Flash              | See 80001400                                                                                                                        |
| 80002500   | —                 | Flash              | See 80001400                                                                                                                        |
| 90001600   | —                 | Copy Utility       | Not enough VDISK space. Unable to copy files.                                                                                       |



---

## Appendix B. Parts Listings

This parts listing contains reference drawings and a corresponding index for all field-replaceable parts. The index provides the part number, the quantity required (units), and a description of the part.

The following list provides additional information about the parts assembly index.

**SIMILAR ASSEMBLIES:** If two assemblies contain a majority of identical parts, they are broken down on the same list. Common parts are shown by one index number. Parts specific to one or the other of the assemblies are listed separately and identified by description.

**AR:** (As Required) in the Units column indicates that the quantity is not the same for all machines.

**NP:** (Non-Procurable) in the Units column indicates that the part is non-procurable and that the individual parts or the next higher assembly should be ordered.

**NR:** (Not Recommended) in the Units column indicates that the part is procurable but not recommended for field replacement, and that the next higher assembly should be ordered.

**R:** (Restricted) in the Units column indicates that the part has a restricted availability.

# Assembly 1: Final Assembly, 2216 - Model 400

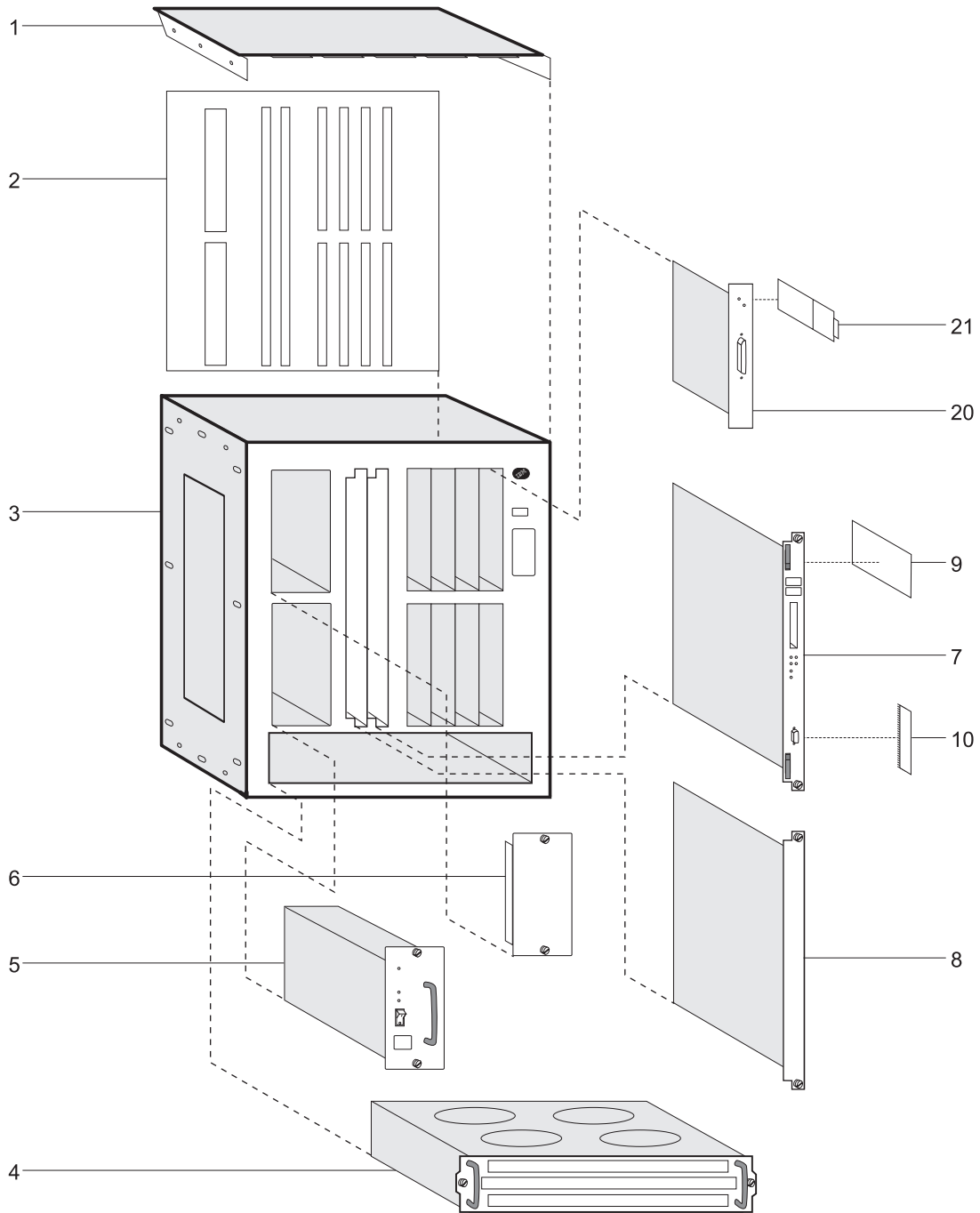



| Asm-<br>Index | Part<br>Number | Units | Description                                                                                         |
|---------------|----------------|-------|-----------------------------------------------------------------------------------------------------|
| 1-            |                | NP    | Final Assembly                                                                                      |
| -1            | 13H4931        | 1     | • Cover, Top                                                                                        |
| -2            | 85H7860        | 1     | • Backplane 2216-400                                                                                |
| -3            | 72H5099        | 1     | • Enclosure                                                                                         |
| -4            | 85H6840        | 1     | • Fan Tray Assembly                                                                                 |
| -5            | 72H5081        | 1     | • Power Supply -- FC 2871                                                                           |
| -6            | 41H7701        | 1     | • Power Supply Filler Plate                                                                         |
| -7            | 30L5820        | 1     | • System Card (with 64-MB of memory)-- FC 2851                                                      |
| -             | 85H7916        |       | • Obsolete                                                                                          |
| -             | 25L5177        | 1     | • System Card (holds up to 256-MB of memory)-- FC 2855                                              |
| -             | 25L4784        | 1     | • System Card (holds up to 256-MB of memory)-- FC 2855                                              |
| -             | 85H9682        |       | • Obsolete                                                                                          |
| -             | 30L6699        | 1     | • System Card (holds up to 512-MB of memory)-- FC 2856                                              |
| -8            | 72H5101        | 1     | • Filler Plate (system slot)                                                                        |
| -             | 72H5098        | 1     | • LIC Filler Plate                                                                                  |
| -9            | 85H7917        | 1     | • Hard Drive (2.5" Hardfile)                                                                        |
| -10           | 85H9688        | 1     | • 64-MB DIMM memory                                                                                 |
| -             | 25L4785        | 1     | • 128-MB DIMM memory                                                                                |
| -             | 30L7395        | 1     | • 256-MB DIMM memory                                                                                |
| -20           | 02L1873        | 1     | • LIC 280 2-Port Token Ring -- FC 2280                                                              |
| -             | 02L1872        | 1     | • LIC 281 2-Port Ethernet -- FC 2281                                                                |
| -             | 85H4872        | 1     | • LIC 282 8-Port RS-232 -- FC 2282                                                                  |
| -             | 02L2065        | 1     | • LIC 283 1-Port ISDN Pri (T1) -- FC 2283                                                           |
| -             | 85H4894        | 1     | • LIC 284 1-Port 155Mbps (MMF ATM) -- FC 2284                                                       |
| -             | 86H0967        | 1     | • LIC 286 1-Port FDDI -- FC 2286                                                                    |
| -             | 85H4878        | 1     | • LIC 287 1-Port ESCON Channel -- FC 2287                                                           |
| -             | 86H1005        | 1     | • LIC 288 1-Port 10/100 Mbps Ethernet -- FC 2288                                                    |
| -             | 85H9703        | 1     | • LIC 289 1-Port HSSI -- FC 2289                                                                    |
| -             | 85H4874        | 1     | • LIC 290 6-Port V.35/V.36) -- FC 2290                                                              |
| -             | 85H4876        | 1     | • LIC 291 8-Port X.21 -- FC 2291                                                                    |
| -             | 02L2066        | 1     | • LIC 292 1-Port ISDN Pri (E1) -- FC 2292                                                           |
| -             | 85H6834        | 1     | • LIC 293 1-Port 155Mbps (SMF ATM) -- FC 2293                                                       |
| -             | 86H0986        | 1     | • LIC 294 1-Port 155Mbps (MMF ATM) -- FC 2294                                                       |
| -             | 86H0993        | 1     | • LIC 295 1-Port 155Mbps (SMF ATM) -- FC 2295                                                       |
| -             | 02L2331        | 1     | • LIC 297 Multiport ISDN PRI/Channelized (T1/J1) base card -- for FC 2297 and 2251                  |
| -             | 02L2333        | 1     | • LIC 298 Multiport ISDN PRI/Channelized (E1) base card -- for FC 2298 and 2252                     |
| -             | 02L2337        | 1     | • LIC 299 Parallel Channel -- FC 2299                                                               |
| -21           | 02L2120        | 1     | • 4-port ISDN PRI/Channelized T1 daughter card -- FC 2251 used on LIC 297                           |
| -             | 02L2123        | 1     | • 4-port ISDN PRI/Channelized E1 daughter card -- FC 2252 used on LIC 298                           |
| -25           | 85H7923        | 1     | • Wrap Plug Service Kit 2216-400 (not illustrated) -- FC 2505 (see page 3-1 for a list of contents) |
| -26           | 25L4749        | 1     | • Wrap Plug for LIC 297 and 298 (not illustrated)                                                   |
| -27           | 25L4747        | 1     | • Terminator for LIC 299 (not illustrated)                                                          |
| -28           | 71F1184        | 1     | • Wrap plug for LIC-299 (not illustrated)                                                           |
| -29           | 10H5569        | 1     | • Serial Cable 9-pin to 25-pin (not illustrated)                                                    |
| -30           | 10H5570        | 1     | • Null modem adapter (not illustrated)                                                              |

## Assembly 2: Final Assembly, 2216 - Model TX1 or TN1

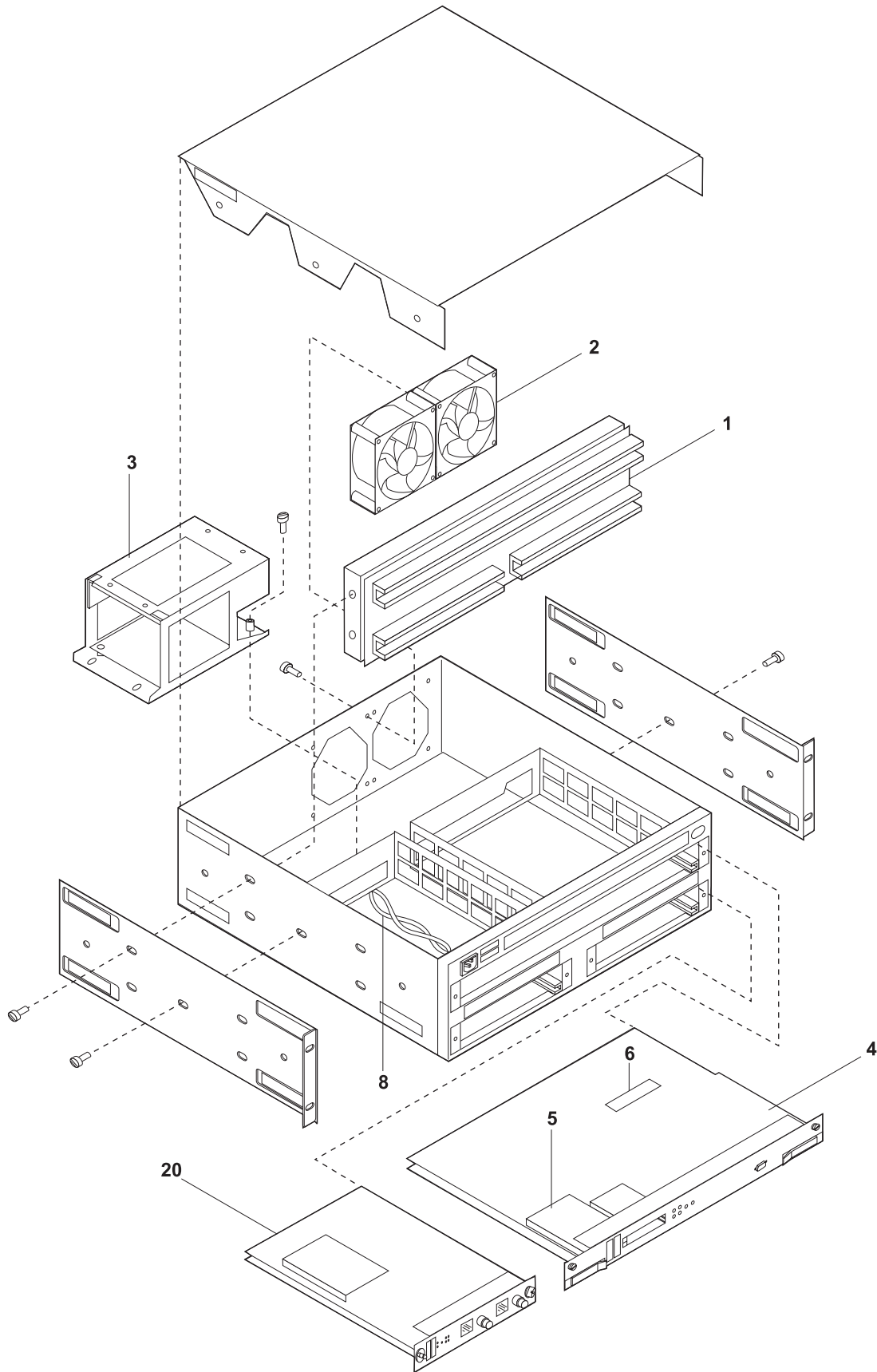

| Asm-<br>Index | Part<br>Number | Units | Description                                                                                         |
|---------------|----------------|-------|-----------------------------------------------------------------------------------------------------|
| 2-            |                | NP    | Final Assembly                                                                                      |
| -1            | 25L4786        | 1     | • Backplane 2216 Model TX1 or TN1                                                                   |
| -2            | 25L4787        | 1     | • Fan Unit (single fan)                                                                             |
| -3            | 25L4788        | 1     | • Power Assembly                                                                                    |
| -             |                |       | •                                                                                                   |
| -4            | 30L6699        | 1     | • System Card                                                                                       |
| -             | 25L4784        |       | • Obsolete                                                                                          |
| -             |                |       | •                                                                                                   |
| -5            | 85H7917        | 1     | • Hard Drive (2.5" Hardfile)                                                                        |
| -             |                |       | •                                                                                                   |
| -6            | 25L4785        | 1     | • 128-MB DIMM memory                                                                                |
| -             | 30L7395        | 1     | • 256-MB DIMM memory                                                                                |
| -             |                |       | •                                                                                                   |
| -7            | 25L4789        | 1     | • DC Cable Assembly 48v (Not Illustrated)                                                           |
| -             | 25L4790        | 1     | • DC Cable Assembly 5v (Not Illustrated)                                                            |
| -8            | 25L4791        | 1     | • AC Inlet Cable Assembly                                                                           |
| -             |                |       | •                                                                                                   |
| -20           | 02L1873        | 1     | • LIC 280 2-Port Token Ring -- FC 2280                                                              |
| -             | 02L1872        | 1     | • LIC 281 2-Port Ethernet -- FC 2281                                                                |
| -             | 85H4872        | 1     | • LIC 282 8-Port RS-232 -- FC 2282                                                                  |
| -             | 86H0967        | 1     | • LIC 286 1-Port FDDI -- FC 2286                                                                    |
| -             | 85H4878        | 1     | • LIC 287 1-Port ESCON Channel -- FC 2287                                                           |
| -             | 86H1005        | 1     | • LIC 288 1-Port 10/100 Mbps Ethernet -- FC 2288                                                    |
| -             | 85H9703        | 1     | • LIC 289 1-Port HSSI -- FC 2289                                                                    |
| -             | 85H4874        | 1     | • LIC 290 6-Port V.35/V.36) -- FC 2290                                                              |
| -             | 85H4876        | 1     | • LIC 291 8-Port X.21 -- FC 2291                                                                    |
| -             | 86H0986        | 1     | • LIC 294 1-Port 155Mbps (MMF ATM) -- FC 2294                                                       |
| -             | 86H0993        | 1     | • LIC 295 1-Port 155Mbps (SMF ATM) -- FC 2295                                                       |
| -             | 02L2337        | 1     | • LIC 299 Parallel Channel -- FC 2299                                                               |
| -             | 72H5098        | 1     | • LIC Filler Plate                                                                                  |
| -             |                |       | •                                                                                                   |
| -25           | 85H7923        | 1     | • Wrap Plug Service Kit 2216-400 (Not Illustrated) -- FC 2505 (see page 3-1 for a list of contents) |
| -27           | 25L4747        | 1     | • Terminator for LIC 299 (Not Illustrated)                                                          |
| -28           | 71F1184        | 1     | • Wrap plug for LIC-299 (Not Illustrated)                                                           |
| -29           | 10H5569        | 1     | • Serial Cable 9-pin to 25-pin (Not Illustrated)                                                    |
| -30           | 10H5570        | 1     | • Null modem adapter (Not Illustrated)                                                              |
| -31           | 72H5163        | 1     | • EtherJet LAN adapter (Not Illustrated)                                                            |
| -32           | 30L6167        | 1     | • EtherJet LAN cable (Not Illustrated)                                                              |

## 2216 PCMCIA Modem and Cable Feature Codes for 2216 Model 400 or Network Utility Model TX1 or TN1

*Table B-1. PCMCIA Modem Feature Codes listed by geography. Use modem cable 85H3589 with the PCMCIA modem*

| <b>PN</b> | <b>Feature Code</b> | <b>Description</b> |
|-----------|---------------------|--------------------|
| 85H3551   | FC 2902             | Australia          |
| 85H3550   | FC 2901             | Austria            |
| 85H3552   | FC 2903             | Belgium            |
| 85H3549   | FC 2900             | Canada             |
| 85H3553   | FC 2904             | Denmark            |
| 85H3554   | FC 2905             | Finland            |
| 85H3555   | FC 2906             | France             |
| 85H3556   | FC 2907             | Germany            |
| 85H3557   | FC 2908             | Hong Kong          |
| 85H3558   | FC 2909             | Ireland            |
| 85H6839   | FC 2927             | Israel             |
| 85H3559   | FC 2910             | Italy              |
| 85H3560   | FC 2911             | Japan              |
| 85H3561   | FC 2912             | Korea              |
| 85H3562   | FC 2913             | Luxembourg         |
| 85H3563   | FC 2914             | Netherland         |
| 85H3564   | FC 2915             | New Zealand        |
| 85H3565   | FC 2916             | Norway             |
| 85H3569   | FC 2921             | Sweden             |
| 85H3570   | FC 2922             | Switzerland        |
| 85H3571   | FC 2925             | UK                 |
| 85H3549   | FC 2900             | U.S.A.             |

Table B-2. 2216 Model 400 Cable Feature Codes

| PN                                                             | Feature Code                                                   | Description                                                                                                                                                                                                                                           |
|----------------------------------------------------------------|----------------------------------------------------------------|-------------------------------------------------------------------------------------------------------------------------------------------------------------------------------------------------------------------------------------------------------|
| 71G3497<br>38H7071<br>59G7195                                  | FC 2701<br>FC 2705<br>FC 2706                                  | LIC 282 EIA-232/V.24 fanout cable<br>LIC 282 EIA-232/V.24 serial interface<br>LIC 282 EIA-232/V.24 direct attach                                                                                                                                      |
| 86H0971<br>-                                                   | -<br>-                                                         | LIC 289 HSSI DTE/DCE cable<br>LIC 289 HSSI Null Modem cable                                                                                                                                                                                           |
| 85H3509<br>80G3984<br>57G8042<br>31L3156<br>30L6524<br>30L6523 | FC 2714<br>FC 2715<br>FC 2716<br>FC 2717<br>FC 2718<br>FC 2719 | LIC 283 ISDN PRI cable (T1)<br>LIC 292 ISDN PRI cable (E1)<br>LIC 283 ISDN PRI cable (J1)<br>LIC 297 ISDN PRI cable (T1) RJ-48C to RJ-48C<br>LIC 298 ISDN PRI cable (E1) RJ-48C to flying leads<br>LIC 297 ISDN PRI cable (J1) RJ-48C to keyed RJ-48C |
| 41H9082                                                        | FC 2713                                                        | multipurpose RJ-45 STP cable                                                                                                                                                                                                                          |
| 11H4958<br>72F0165<br>38H7075<br><br>11H4958<br>1749352        | FC 2707<br>FC 2702<br>FC 2708<br><br>FC 2799                   | LIC 290 V.35 serial interface<br>LIC 290 V.35 fanout cable<br>LIC 290 V.35 direct attach<br><br><i>for France:</i><br>V.35 serial interface cable<br>V.35 serial interface extension cable                                                            |
| 38H7079<br>38H7077<br>73H2507                                  | FC 2709<br>FC 2710<br>FC 2703                                  | LIC 290 V.36 serial interface<br>LIC 290 V.36 direct attach<br>LIC 290 V.36 fanout cable                                                                                                                                                              |
| 25L4746<br>25L4743<br>25L4744                                  | -<br>FC 2720<br>FC 2721                                        | LIC 299 V-cable<br>Channel Interface-in cable<br>Channel Interface-out cable                                                                                                                                                                          |
| 38H7070<br>38H7073<br>06H4648                                  | FC 2711<br>FC 2712<br>FC 2704                                  | LIC 291 X.21 serial interface<br>LIC 291 X.21 direct attach<br>LIC 291 X.21 fanout cable                                                                                                                                                              |

Table B-3. 2216 Model TX1 or TN1 Cable Feature Codes

| PN                                                      | Feature Code                                 | Description                                                                                                                                                                                |
|---------------------------------------------------------|----------------------------------------------|--------------------------------------------------------------------------------------------------------------------------------------------------------------------------------------------|
| 71G3497<br>38H7071<br>59G7195                           | FC 2701<br>FC 2705<br>FC 2706                | LIC 282 EIA-232/V.24 fanout cable<br>LIC 282 EIA-232/V.24 serial interface<br>LIC 282 EIA-232/V.24 direct attach                                                                           |
| 86H0971<br>-                                            | -<br>-                                       | LIC 289 HSSI DTE/DCE cable<br>LIC 289 HSSI Null Modem cable                                                                                                                                |
| 41H9082                                                 | FC 2713                                      | multipurpose RJ-45 STP cable                                                                                                                                                               |
| 11H4958<br>72F0165<br>38H7075<br><br>11H4958<br>1749352 | FC 2707<br>FC 2702<br>FC 2708<br><br>FC 2799 | LIC 290 V.35 serial interface<br>LIC 290 V.35 fanout cable<br>LIC 290 V.35 direct attach<br><br><i>for France:</i><br>V.35 serial interface cable<br>V.35 serial interface extension cable |
| 38H7079<br>38H7077<br>73H2507                           | FC 2709<br>FC 2710<br>FC 2703                | LIC 290 V.36 serial interface<br>LIC 290 V.36 direct attach<br>LIC 290 V.36 fanout cable                                                                                                   |
| 25L4746<br>25L4743<br>25L4744                           | -<br>FC 2720<br>FC 2721                      | LIC 299 V-cable<br>Channel Interface-in cable<br>Channel Interface-out cable                                                                                                               |
| 38H7070<br>38H7073<br>06H4648                           | FC 2711<br>FC 2712<br>FC 2704                | LIC 291 X.21 serial interface<br>LIC 291 X.21 direct attach<br>LIC 291 X.21 fanout cable                                                                                                   |

---

## Appendix C. Model 400 and Model TX1 or TN1 Hardware Characteristics

---

### Physical Specifications of the IBM 2216 Nways Multiaccess Connector Model 400

The dimensions of the 2216 Model 400 are as follows:

**Width**

440 mm (17.3 in.) without rack-mounting flange  
480 mm (18.9 in.) with rack-mounting flange

**Depth**

358 mm (14.1 in.)

**Height**

572 mm (22.5 in.) (13U) without rubber feet pads  
576.1 mm (22.7 in.) (13U) with rubber feet pads

### Weight

The base box of the Model 400 (with one power supply), system card, no adapters, a power supply filler plate, and no adapter filler plates weighs 31.6 kg (69.7 lb).

- Each adapter weighs approximately 1 kg (2.2 lb).
- Each filler plate for an unoccupied adapter slot weighs 0.1 kg (0.2 lb).
- A filler plate for a second power supply weighs 0.2 kg (0.4 lb)
- A second power supply weighs 3.5 kg (7.7 lb).

A fully populated Model 400 with a second power supply and eight adapters will weigh about 43.1 kg (95 lb).

**Note:** During installation, two people will be required to lift the 2216.

### Service Clearances

You must leave free space for service around the machine as follows:

**Front** 750 mm (30 in.)  
**Sides** No clearance required  
**Rear** No clearance required

### Airflow

A multiple-fan (forced air) ventilation system is installed in each unit. The airflow is 2.0 cubic meters per minute (71 cubic feet per minute).

**Note:** Airflow is dependent on keeping the vents on the front and rear unobstructed.

## Operating Environment

|                          |                                |
|--------------------------|--------------------------------|
| <b>Temperature</b>       | 10°C to 40.6°C (50°F to 105°F) |
| <b>Relative Humidity</b> | 8% to 80%                      |
| <b>Max Wet Bulb</b>      | 26.7°C (80°F)                  |

## Lightning Protection

The power supplies of the Model 400 are protected against lightning.

Contact an electrical contractor to determine if lightning protection is needed for your power distribution system.

## Electromagnetic Interference

Refer to G-2 for detailed information regarding the operating environment of the Model 400.

## Power Supply

The Model 400 can have one or two power supplies. A single power supply can provide power for a fully configured unit. If you use two supplies, they will share the power load. The first power supply will remain fully operational while a second is either being installed or removed. The second power supply must have its power switch in the off position while it is being installed or removed. If a second power supply is not installed, a filler plate is used to cover the position where it would have been installed.

The power supply uses a voltage sensing system that converts line current of 100—240 volts ac, 50/60 Hz single-phase, to dc input as required by the system card, the adapters, and the fan tray.

### Power Supply Requirements

For the Model 400, the ac power source must be able to supply:

- 100 to 240 V ac (nominal voltage)
- 50 or 60 Hz
- Single phase
- 0.62 kVA power
- 70 amps peak inrush current for one quarter cycle per supply

### Power Cord

See “Power Cord Characteristics” on page C-4 for detailed information regarding the operating environment of the Model 400.

---

## Physical Specifications of the Network Utility

The dimensions of the Network Utility are as follows:

### Width

440 mm (17.3 in.) without rack-mounting flange  
480 mm (18.9 in.) with rack-mounting flange

### Depth

457.2 mm (18 in.)



**Height**

133 mm (5.2 in.) (3U) with rubber feet pads (as shipped)

**Weight**

The Network Utility base box (mechanical chassis with backplane, a power supply, system card, and fan assembly) weighs 13 kg (28.5 lb).

- Each adapter weighs approximately 1 kg (2.2 lb).
- Each filler plate for an unoccupied adapter slot weighs 0.1 kg (0.2 lb).

A Network Utility populated with two adapters weighs about 15 kg (33 lb).

**Service Clearances**

You must leave free space for service around the Network Utility as follows:

|              |                       |
|--------------|-----------------------|
| <b>Front</b> | 750 mm (30 in.)       |
| <b>Sides</b> | No clearance required |
| <b>Rear</b>  | No clearance required |

**Airflow**

A dual-fan (forced air) ventilation system is installed in the Network Utility. Volumetric flow is 0.99 m<sup>3</sup>/min. (35 ft<sup>3</sup>/min.).

**Note:** Airflow is dependent on keeping the vents on the front, sides, and rear unobstructed.

**Operating Environment**

See “Operating Environment” on page C-2 for detailed information regarding the operating environment of the Network Utility.

**Lightning Protection**

See “Lightning Protection” on page C-2 for detailed information regarding the operating environment of the Network Utility.

**Electromagnetic Interference**

See G-2 for detailed information regarding the operating environment of the model TX1 or TN1.

**Power Subsystem**

The Network Utility power subsystem consists of two supplies mounted in an enclosure. It is secured by four locking slots and two screws and connects to the backplane assembly with two cable assemblies which provide power for a fully configured unit.

The power subsystem uses a voltage sensing system that converts line current of 100 to 240 volts ac, 50/60 Hz single-phase, to dc input as required by the system card, the adapters, and the fan assembly.

## Power Supply Requirements

For the Network Utility, the ac power source must be able to supply:

- 100 to 240 V ac (nominal voltage)
- 50 or 60 Hz
- Single phase
- 0.26 kVA power
- 100 amps peak inrush current for one quarter cycle

## Power Cord

See “Power Cord Characteristics” for detailed information regarding the operating environment of the Network Utility.

## Power Cord Characteristics

Both Model 400 and Network Utility use the ac power cord. The cord is supplied with a country-dependent plug. For each of the cords listed in Table C-1, find its plug type in Figure C-1 on page C-5 by comparing *index* numbers. (The index number is displayed below each plug type in Figure C-1.)

| Index | Part Number | Feature Code | Countries                                                                                                                                                                       | Power Cord                | Plug Standard   |
|-------|-------------|--------------|---------------------------------------------------------------------------------------------------------------------------------------------------------------------------------|---------------------------|-----------------|
| 1     | 1838574     | 9833         | Canada, Japan, Philippines, Taiwan, Thailand, Bolivia, Brazil, Ecuador, Peru, Venezuela, United States                                                                          | 250 V, 10 A, 2.7 m (9 ft) | NEMA WD-1 6-15P |
| 2     | 6952300     | 9810         | United States (except Chicago), Puerto Rico, Canada, Japan, South Korea, Philippines, Taiwan, Saudi Arabia, Mexico, Bolivia, Brazil, Colombia, Ecuador, Peru, Venezuela, Panama | 125 V, 10 A, 2.7 m (9 ft) | NEMA WD-1 5-15P |
| 2     | 6952301     | 9815         | United States (Chicago only)                                                                                                                                                    | 125 V, 10 A, 1.8 m (6 ft) | NEMA WD-1 5-15P |
| 2     | 1838576     | 9818         | United States (Chicago only)                                                                                                                                                    | 250 V, 10 A, 1.8 m (6 ft) | NEMA WD-1 5-15P |
| 3     | 13F9979     | 9820         | Indonesia, South Korea, Macau, Austria, Belgium, Finland, France, Germany, Greece, Norway, Portugal, Saudi Arabia, Spain, Sweden, Turkey, Netherlands, China, Brazil            | 250 V, 10 A, 2.7 m (9 ft) | CEE7 VII        |
| 4     | 14F0033     | 9825         | Brunei, China, Hong Kong, India, Malaysia, Singapore, Ireland, Kuwait, United Arab Emirates, United Kingdom                                                                     | 250 V, 10 A, 2.7 m (9 ft) | BS 1363         |
| 5     | 14F0051     | 9828         | Switzerland, Liechtenstein                                                                                                                                                      | 250 V, 10 A, 2.7 m (9 ft) | SEV 24507       |

| <i>Table C-1 (Page 2 of 2). Power Cords and Power Plug Standards</i> |                    |                     |                                                              |                              |                         |
|----------------------------------------------------------------------|--------------------|---------------------|--------------------------------------------------------------|------------------------------|-------------------------|
| <b>Index</b>                                                         | <b>Part Number</b> | <b>Feature Code</b> | <b>Countries</b>                                             | <b>Power Cord</b>            | <b>Plug Standard</b>    |
| 6                                                                    | 14F0069            | 9830                | Italy, Chile                                                 | 250 V, 10 A,<br>2.7 m (9 ft) | CEI 23-16               |
| 7                                                                    | 13F9997            | 9821                | Denmark                                                      | 250 V, 10 A.<br>2.7 m (9 ft) | Normblad 4              |
| 8                                                                    | 14F0087            | 9827                | Israel                                                       | 250 V, 10 A,<br>2.7 m (9 ft) | SII-32-1971             |
| 9                                                                    | 13F9940            | 9831                | Australia, New Zealand,<br>Argentina, China                  | 250 V, 10 A,<br>2.7 m (9 ft) | AS 3122-1981<br>NZS 198 |
| 9                                                                    | 6952291            | 9834                | Argentina, Colombia, Brazil,<br>Paraguay, Uruguay            | 250 V, 10 A,<br>2.7 m (9 ft) | IEC 83-A5<br>1957       |
| 10                                                                   | 14F0015            | 9829                | Bangladesh, Myanmar, Sri<br>Lanka, Pakistan, South<br>Africa | 250 V, 10 A,<br>2.7 m (9 ft) | SABS 164 BS<br>546      |

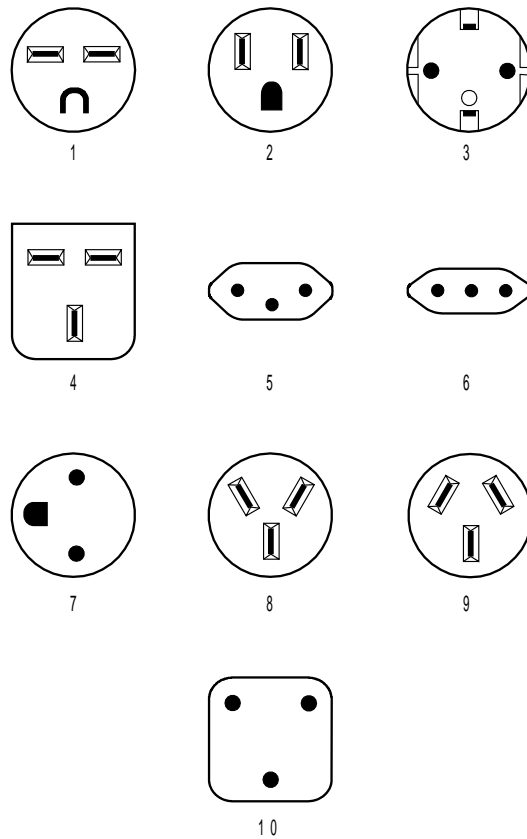

Figure C-1. Power Cord Plugs by Country



---

## Appendix D. Managing Operational Code and Configuration Files

This chapter explains how to manage the operation code images and configuration files on the IBM 2216 Model 400 or Network Utility Model TX1 or TN1. The procedures in this section use the term IBM 2216 to refer to either the 2216 Model 400 or Network Utility.

---

### Reconfiguring

You might find it hard to detect problems caused by configuration errors. A configuration error can initially appear to be a hardware problem because the IBM 2216 will not start or data will not flow through a port. In addition, problems with configuration may not result in an error initially; an error may occur only when specific conditions are encountered or when heavy network traffic occurs.

If you cannot resolve a problem after making a few changes to your configuration or after restoring the active configuration file, it is recommended that you generate a new configuration. Too many changes to a configuration often compound the problem, whereas you can usually generate and test a new configuration within a few hours.

---

### Managing the Operational and Configuration Software

Operational software is loaded at the factory. If the operational software needs an upgrade or replacement, you have to reload it. Binary configuration files can be created using the Configuration Program. These files can be uploaded to the IBM 2216 to reconfigure it.

### Software and Configuration Change Management

The IBM 2216 is capable of storing two copies of its operational software and four copies of configuration information for each copy of the operational software. Without interrupting the operation of the IBM 2216, you can store software or configuration files in it. Changes to the configuration are activated in one of the following ways: immediately, after a timed interval, or at the next restart.

Should the IBM 2216 fail when a new version of the operational software is activated, one of the backup versions can be restored.

You use the command line interface for change management operations and TFTP or Xmodem to transfer files. For more information, see the "File Transfer Using TFTP" on page D-3 and "File Transfer Using Xmodem" on page D-5

---

### How Software Files Are Managed

To help you manage operational software upgrades and configurations, the IBM 2216 has a software change management feature. This utility enables you to determine which operational software file and which configuration file is active while the IBM 2216 is running.

## How to View the Files

To use the change management tool in the command line interface to view the operational software image and the configuration files, follow these steps:

1. From the OPCON prompt, which is an asterisk (\*), type **talk 6** and press **Enter**. The Config> prompt appears.
2. Type **boot** and press **Enter**. You will see the prompt Boot config>.
3. Type **list** and press **Enter**. You will see a list similar to this one:

```
Boot config> list
```

```
BANK A                                BANK B
IMAGE - ACTIVE                        IMAGE - AVAIL
CONFIG 1 - ACTIVE                     CONFIG 1 - AVAIL
CONFIG 2 - AVAIL                      CONFIG 2 - AVAIL
CONFIG 3 - NONE                       CONFIG 3 - NONE
CONFIG 4 - NONE                       CONFIG 4 - NONE
```

Each bank represents one image of the operational code. The images stored in BANK A and BANK B are stored on the hard drive. The Configs represent the configuration files that are stored with each bank. *IMAGE* refers to the status of the operational software and *CONFIG* refers to the status of the configuration files.

The possible IMAGE and CONFIG status:

|                |                                                                                                                                                                                                                                                                       |
|----------------|-----------------------------------------------------------------------------------------------------------------------------------------------------------------------------------------------------------------------------------------------------------------------|
| <b>ACTIVE</b>  | This file is currently loaded in active memory and is running on the IBM 2216.<br><br><b>Note:</b> The status of this file can be changed only by resetting the IBM 2216. <i>If a config or an image is active, it is locked and cannot be overwritten or erased.</i> |
| <b>AVAIL</b>   | This is a good file that can be made active.                                                                                                                                                                                                                          |
| <b>CORRUPT</b> | This file was damaged or was not loaded into the IBM 2216 completely.                                                                                                                                                                                                 |
| <b>PENDING</b> | This file will be loaded and become active the next time the IBM 2216 is reset.                                                                                                                                                                                       |
| <b>LOCAL</b>   | This file will become active at the next reset. This reset will cause the currently ACTIVE file to become PENDING. LOCAL is a status that makes a file ACTIVE only for one reset of the IBM 2216.                                                                     |

Only one bank at a time contains an ACTIVE image. Only one configuration file is ACTIVE and it must be within the ACTIVE bank.

## How to Reset the IBM 2216

**Attention:** A reset interrupts the function of the IBM 2216 for up to 90 seconds. Be sure that the network is prepared for the interruption.

As previously stated, PENDING and LOCAL files are not loaded into active memory until you reset the IBM 2216.

You can reset the IBM 2216 using any one of these methods:

- Press the hardware reset on the system card.

- At the OPCON prompt (\*), type **reload** and press **Enter**.
- At the Config only> prompt, type **reload** and press **Enter**.

**Note:** The Config only> prompt appears when no file is active. Lack of an active file indicates that an active configuration has become corrupted or that the IBM 2216 is not configured.

## File Transfer Using TFTP

Use this sequence of commands to transfer a file from a workstation or server to the IBM 2216 using TFTP. You will need to substitute your own values for the IP address and path, which are given as examples. The number of bytes received is also an example.

**Note:** You transfer the files to banks within the IBM 2216. The banks represent the directories that you have created; you do not have to be concerned about transferring the files to a particular directory within the IBM 2216.

### TFTP File Transfer using the Operating Software

**Note:** You cannot use the TFTP file transfer method in the operating software to migrate from Version 1 to Version 2 or Version 3 of the MAS code. (See “Migrating to a New Code Level” on page D-5 for migration directions which explicitly lead you through the firmware method to migrate to a new level of code.)

1. From the OPCON prompt, which is an asterisk (\*), type **talk 6** and press **Enter**. The Config> prompt appears.
2. Type **boot** and press **Enter**. The Boot config> prompt is displayed.
3. To get the MAS software code load:
  - Enter **tftp get load modules** (for MAS software Version 2 or above)
  - Enter **tftp get load single image** (below MAS software Version 2).

To get a configuration file, enter **tftp get config**

You cannot overwrite a currently active bank image.

4. When prompted, specify the IP address of the TFTP server.
5. When prompted:
  - Specify the path/file name for a single image
  - or
  - Specify just the path for load modules

With Version 2 or later, when you specify that you want load modules to transfer, all of the appropriate load modules in the specified directory will be transferred.

There could be up to 20 separate load modules. All the load modules must be in the same directory to enable the successful transfer of all the modules.

The following example shows a Version 2 or later software code load:

```

* talk 6
Config> boot
Boot config> tftp get load modules
Specify the server IP address (dotted decimal): [1.2.3.4] 192.9.200.1
Specify the remote files directory: (/u/bin/) /usr/601bin/204img/
Select the destination bank: (A,B): [A] a
TFTP SW load image
  get: /usr/601bin/204img/LML.ld
  from: 192.9.200.1
  to:  bank A.

```

Operation completed successfully.

## TFTP File Transfer using the Firmware

1. From the main firmware menu ("Systems Management Services," select (4. utilities)
2. From the "Systems Management Utilities" menu select (12. Change Management).
3. From the "Change Management Software Control" menu select (10. TFTP software).

**Note:** You must have setup your IP addresses on the devices before you can TFTP. (See section "Setting Up Remote Initial Program Load" on page 8-19 to setup IP parameters in the firmware.)

4. Select the type of software from the "Select Type" dialog box.
5. Select which bank from "Select Bank" dialog box
6. If you selected 2. Load Image, you will be prompted to select the type of load image (that is, single image or modules).
  - If the code load you want to transfer consists of an LML.ld file plus other load modules ending in .ld, select **modules**.
  - If you want to transfer a single image (the type that existed in MAS Version 1 Release 1), select **single image**.
7. When prompted, type in either the Directory Path to the modules, or for the path/filename for the single image. The modules should all be in one directory.
8. When prompted, select the medium for tftp. For example, you might have choices for PCMCIA, LIC adapters, and SLIP (depending on the adapters in your machine).
9. If you selected modules and the directory path you entered has all read permissions correct for 'anybody' to retrieve, you will see successive message boxes appear as each load module is transferred.
 

If you select single image, only one message box will appear to inform you of the file transfer.
10. Select the Set Boot Information option on the Change Management menu and select:
  - The Bank to boot from
  - The Config to boot with
  - Permanent or once



## File Transfer Using Xmodem

If you use Xmodem, you will get similar prompts that enable you to specify the bank for the image files or the bank and the config number for the configuration files that you transfer. The interface for transferring is designed so that you cannot overwrite any ACTIVE file. (Xmodem is available only from the firmware.)

For transfers via modem, each load module must be separately named and transferred individually.

**Note:** When using Xmodem to transfer a multiple load module image (used in Version 2 in the form of several files ending in .ld), **you must** transfer each of the modules (.ld files) one by one to get the entire load module image.

When an entire load image has transferred, the status of the bank will change from CORRUPT to AVAIL. Transfer file LML.ld first. Unless you see an information message ERROR WRITING FILE appear, assume each individual transfer has been successful.

## Migrating to a New Code Level

### Notes:

1. In Version 1 Release 1 of the MAS, the lower level code does not have any enhanced ability to retrieve the newer versions of operating code levels. If you attempt to use the **talk 6** in the operating code, the file transfer attempt will be unsuccessful.
2. **You must use either the firmware tftp or Xmodem to get the new level of code.**

To upgrade from any earlier release of operational code to a later level, do the following:

1. Follow the instructions in “Updating System Firmware” on page 8-14 to update the system firmware to the Version 2 or later level.
2. After starting the Firmware, select the following sequence of menus:
  - Utilities menu
  - Change Management

Then, select the TFTP Software option.

**Note:** You must have setup your IP addresses on the devices before you can TFTP. (See section “Setting Up Remote Initial Program Load” on page 8-19 to setup IP parameters in the firmware.)

3. Respond to the prompt to select which type of load to do (a configuration file or a load image).
4. Respond to the prompt to select which bank to load.

**Note:** Files to be retrieved from the server should all be in the same directory, and their permissions should be such that read is allowed for anybody.

5. After you selected **2. Load Image**, you will be prompted to select the type of load image (that is, single image or modules).
  - If the code load that you want to transfer consists of an LML.ld file plus other load modules ending in .ld, select **modules**.

6. When the prompt Enter Directory Path to Remote Load Modules appears, enter the *pathname* to retrieve all load modules belonging to this load image.
7. When prompted, select the medium to use for TFTP. Depending on the adapters in your machine, there could be choices for PCMCIA, several adapters, and SLIP.
8. Information boxes appear as each load module is being transferred using TFTP. Some time will transpire as each transferred load module is written to the disk. An average load may take 10-12 minutes. When the entire load has been transferred, the previous menu is displayed.

The Version 2 or later operational code comes in the form of multiple load modules, headed by LML.ld.

All load modules for a load must be in the same directory on the server for this transfer.

9. Select the Set Boot Information option on the Change Management menu and select:
  - The Bank to boot from
  - The Config to boot with
  - Permanent or once

Once you have Version 2 or later operational code, you will be able to use the **tftp get load modules** option under `boot config>` to get any further load images.

If you were not able to use TFTP and instead use Xmodem to try to upgrade, select the Xmodem Software option instead of TFTP Software option. In the case of XMODEM file transfers, Xmodem does not retrieve a set of load modules. They must be transferred one by one.

## Using the Configuration Program to Manage the Configuration Files

For optimal configuration management, it is recommended that you use the Configuration Program and its configuration database to manage all your IBM 2216 configuration files.

The design of change management facilitates good control of the configuration files. Keeping the ACTIVE file and the file that is stored in the configuration database the same assures that a copy of the ACTIVE file is always available.

When you use the Send option to send a new configuration to the IBM 2216, the new configuration is written to the ACTIVE bank and overwrites the file located in the position just below the currently ACTIVE configuration. The new configuration is PENDING if a time is set for a reset. If the configuration file is sent without a specified time for the reset to occur, it gets AVAIL status.

For example, suppose that CONFIG 2 is ACTIVE. The new configuration file is written to CONFIG 3. It has a status of PENDING if a reset time is associated with it; if not, it has a status of AVAIL.

If the file has a status of PENDING, CONFIG 2 becomes AVAIL and CONFIG 3 becomes ACTIVE when a reset occurs. The next file that is sent from the Configuration Program will be placed in CONFIG 4. If a reset time is associated with the file, it will have the PENDING status and will become ACTIVE when the

next reset occurs. If another file is then sent, it is placed in CONFIG 1 because the currently ACTIVE file is now in CONFIG 4. This arrangement results in a circular queue.

If the downloaded file has a status of AVAIL, a reset does not change its status. If another file is sent down, it overwrites that file because the ACTIVE file has not changed and the newly downloaded file always occupies the location just behind the ACTIVE file.

### Example of Sending a File from the Configuration Program

For example, suppose that this is the view of the software that is displayed by the **list** command:

```
Boot Config> list
```

|                   |                  |
|-------------------|------------------|
| BANK A            | BANK B           |
| IMAGE - ACTIVE    | IMAGE - AVAIL    |
| CONFIG 1 - ACTIVE | CONFIG 1 - AVAIL |
| CONFIG 2 - AVAIL  | CONFIG 2 - AVAIL |
| CONFIG 3 - NONE   | CONFIG 3 - AVAIL |
| CONFIG 4 - NONE   | CONFIG 4 - NONE  |

The Configuration Program sends a config file to BANK A, CONFIG 2. If the configuration is marked in the Configuration Program to be loaded immediately, the IBM 2216 performs a reset immediately after it received the new configuration. The Send command of the Configuration Program in this situation is composed of these two actions:

1. Send Config to CONFIG 2 as PENDING
2. Reset

After these two actions, the IBM 2216 configuration looks like this:

|                   |                  |
|-------------------|------------------|
| BANK A            | BANK B           |
| IMAGE - ACTIVE    | IMAGE - AVAIL    |
| CONFIG 1 - AVAIL  | CONFIG 1 - AVAIL |
| CONFIG 2 - ACTIVE | CONFIG 2 - AVAIL |
| CONFIG 3 - NONE   | CONFIG 3 - AVAIL |
| CONFIG 4 - NONE   | CONFIG 4 - NONE  |

CONFIG 1 has become AVAIL and CONFIG 2 has become ACTIVE.

If the Configuration Program were now used to send down a new configuration to the IBM 2216 and the file were not marked to be loaded at any specified time, the view of the software in the IBM 2216 would look like this:

|                   |                  |
|-------------------|------------------|
| BANK A            | BANK B           |
| IMAGE - ACTIVE    | IMAGE - AVAIL    |
| CONFIG 1 - AVAIL  | CONFIG 1 - AVAIL |
| CONFIG 2 - ACTIVE | CONFIG 2 - AVAIL |
| CONFIG 3 - AVAIL  | CONFIG 3 - AVAIL |
| CONFIG 4 - NONE   | CONFIG 4 - NONE  |

After this action, CONFIG 3 is AVAIL. The new configuration file has been loaded in this location.

**Note:** You should exercise caution here because any on-board configuration changes could result in overwriting the CONFIG 3 file. Because the configuration file in CONFIG 3 was sent down without any time specified for resetting the server, it is currently not in use. It can be overwritten either when another file is sent from the Configuration Program or when a file is saved using the **write** command from the command line interface. You can use the Copy command to move it to another location to protect it (see “Using the Copy Command” on page D-9).

## Change Management Functions

A few change management commands are described in this section. For complete details of change management, refer to “Performing Change Management Operations” in the *Multiprotocol Access Services Software User's Guide*.

### Describe Load Images

At Boot `config>`, type **describe 2216**. The Product ID, microcode version number, release number, maintenance number, PTF, Feature, and RPQ numbers and the date of the operational software image are displayed.

### Describe Config Images

At Boot `config>`, type **describe config**. For each configuration file that is loaded, its bank, internal location (for example, CONFIG 1), version, and level is displayed.

### Disable Dumping

The IBM 2216 can be set up to dump the contents of memory to permanent storage in the unlikely event of a complete system failure. If dumping is enabled, using this selection will cause the IBM 2216 **not** to dump to disk.

To disable dumping, type **talk 6** or **t 6** at the \* prompt, press **Enter**, and then type **disable dump memory** or **dis dump** at the `Config>` prompt. You will see the message:

```
System memory dump function disabled successfully.
```

### Enable Dumping

This command enables the dumping of memory without intervention from anyone in the event that the IBM 2216 has a catastrophic error. The IBM 2216 will dump memory onto the hard disk. Once a successful dump has been taken, the IBM 2216 attempts to restart. Depending upon the failure of the IBM 2216, it cannot always restart. In this case, you should restart it manually and call a service person who will dial into the IBM 2216 to determine the nature and the causes of the failure.

Before you can enable dumping, you must first enable system rebooting. To enable system rebooting, enter the following commands at the `Config>` prompt.

```
enable reboot-system
enable dump-memory
```

Finally, to enable dumping, type **t 6** at the \* prompt, press **Enter**, and then type **enable** or **ena** at the `Config>` prompt. You will see the message:

```
System memory function enabled successfully
```

The default state is to have dumping enabled.

## Erase Files

The IBM 2216 has a DOS file system structure with user access files in the /sys0 and /sys1 banks. The contents of these banks are the operational software load images and the configuration files. Note that the following rules apply to erasing files from the IBM 2216:

- Image files that are not ACTIVE can be overwritten anytime
- ACTIVE image files **cannot** be erased
- ACTIVE configuration files **cannot** be erased

To erase a file, at the `Boot config>` prompt, type **erase**. Follow the prompts. If you select a file to erase that is BROKEN or NONE, the erase option is discontinued.

## Using the Copy Command

The Copy command allows you to move a file from one location in the storage area to another. This command allows you to change the status as well. The file that you move always receives the status of the storage area that it is moved to. For example, suppose that you have this scenario:

- The configuration file in BANK A CONFIG 1 is AVAIL. The configuration file in BANK B CONFIG 1 is PENDING.
- You copy the configuration in BANK A CONFIG 1 to BANK B CONFIG 1.

In this case, the original configuration file in BANK A CONFIG 1 remains unchanged and AVAIL. The configuration that was in BANK B CONFIG 1 is overwritten by a copy of the configuration file that is in BANK A CONFIG 1. This copy retains the status of the file that it overwritten, in this case, PENDING.

These are the prompts that you would use to perform this copy process.

```
Boot config> copy config  
  
Copy FROM Bank number? A  
  
Copy FROM Config number? 1  
  
Copy TO Bank number? B  
  
Copy TO Config number? 1
```

If you copy an image, the same rules apply except that image files can be copied only from Bank to Bank. These steps describe how the copy of an image affects the image that was previously in the Bank:

1. The copy overwrites the image that was previously in the Bank.
2. The copy acquires the status of the image that was previously in the Bank.

---

## File Transfer

Table D-1 on page D-10 defines the ways in which you can transfer configuration files and operational software files to and from the IBM 2216.

Table D-1. File Transfer

| File Transfer Method                                                                                                                                                                                                                                                                                                                                                                                                                                                                                                                                                                                                                                                                                                                                                                                                                                                                                                                                                                                                                                  | Type of Connection                                                                                                                                                                                                                                                                  |
|-------------------------------------------------------------------------------------------------------------------------------------------------------------------------------------------------------------------------------------------------------------------------------------------------------------------------------------------------------------------------------------------------------------------------------------------------------------------------------------------------------------------------------------------------------------------------------------------------------------------------------------------------------------------------------------------------------------------------------------------------------------------------------------------------------------------------------------------------------------------------------------------------------------------------------------------------------------------------------------------------------------------------------------------------------|-------------------------------------------------------------------------------------------------------------------------------------------------------------------------------------------------------------------------------------------------------------------------------------|
| <p><b>TFTP</b> Get command from the IBM 2216 to the workstation that has the binary configuration file, to download operational software images and configuration files to the IBM 2216. Files sent using TFTP must be binary, or the IBM 2216 cannot use them. Use the Create command of the Configuration Program to save configuration files in binary format before downloading them to the IBM 2216.</p> <p>After the IBM 2216 is operational in the network, you can use the TFTP Put command over IP to upload a file from the IBM 2216 to a workstation. The file will be uploaded in binary format. Both operational software and configuration files can be uploaded.</p> <p>Use the Read router configuration option of the Configuration Program to make an uploaded configuration file usable by the Configuration Program so that you can change some parameter values in it.</p> <p><b>Note:</b> Using TFTP Put is a way to retrieve files from the IBM 2216 if the Retrieve option of the Configuration Program is not available.</p> | <ol style="list-style-type: none"> <li>1. SLIP connection (using the TFTP Get command to download files to the IBM 2216).</li> <li>2. IP connection of operational IBM 2216 over functioning network (using the TFTP Get and Put commands to download and upload files).</li> </ol> |
| <p><b>Xmodem</b> in ProComm or an equivalent communications program from the workstation. This method uses ASCII terminal emulation and can download files to the IBM 2216. The IBM 2216 does not have to be operational in the network to use this method. Configuration and operational files must be in binary format to be used by the IBM 2216.</p> <p><b>Note:</b> This is a second way to retrieve files from the IBM 2216 if the Retrieve option of the Configuration Program is not available.</p>                                                                                                                                                                                                                                                                                                                                                                                                                                                                                                                                           | <p>Serial connection through a modem (PCMCIA or an external modem) or through a null modem.</p>                                                                                                                                                                                     |
| <p>The Communications Option of the <b>Configuration Program</b> (actually, the protocol for this is SNMP). This method cannot be used until the IBM 2216 is operational in the network. The files are not binary, but are in a format that is internal to the Configuration Program. This function can send and retrieve configuration files to the IBM 2216.</p>                                                                                                                                                                                                                                                                                                                                                                                                                                                                                                                                                                                                                                                                                    | <p>IP connection of operational IBM 2216 over functioning network.</p>                                                                                                                                                                                                              |

---

## Appendix E. Adapter Plugging Defaults

- 2216 Model 400 units assembled at the factory follow the plugging rules that are described in this appendix.
- Network Utility Models TN1 and TX1 have no plugging rules or restrictions.

---

### Model 400 Plugging Sequences

Table E-1 illustrates how the slots are numbered: two rows of four slots, numbered 1 through 8.

|        |        |        |        |
|--------|--------|--------|--------|
| Slot 1 | Slot 2 | Slot 3 | Slot 4 |
| Slot 5 | Slot 6 | Slot 7 | Slot 8 |

Table E-2 and Table E-3 show the default sequence of installation for the various adapters.

- FC 2280 and FC 2281 are installed left to right, beginning with slot 1. A maximum of six can be installed in any single IBM 2216.

|        |        |       |  |
|--------|--------|-------|--|
| first  | third  | fifth |  |
| second | fourth | sixth |  |

- Other adapters are installed right-to-left in the first-available slot beginning with slot 8 on the bottom and far right.

|         |       |        |       |
|---------|-------|--------|-------|
| eighth  | sixth | fourth | third |
| seventh | fifth | second | first |

---

### Model 400 Slots and Adapters

There are two large slots, designated *A* and *B*, on the IBM 2216 Model 400. Slot *A* is unused. Slot *B* is occupied by the system card. In addition, there are eight adapter slots, designated 1 through 8.

- 2280 or 2281 — If **six** Token-Ring (FC 2280) and Ethernet (FC 2281) adapters are installed in any combination, no other adapters can be installed.
- 2280 or 2281 — If a combination of **five** 2280 and 2281 adapters is to be installed, then two other adapters can also be installed.
- The IBM 2216 supports a maximum of:
  - **Four** channel adapters, which can be Parallel Channel Adapters (FC 2299) in any combination with ESCON adapters (FC 2287)
  - **Two** ATM adapters (FC 2284, 2293, 2294, or 2295)

**Note:** This adapter is also used for fast token-ring (FasTR)

- **One** 4-port ISDN PRI/Channelized (T1/J1 interface) adapter (FC 2297)

**One** 4-port ISDN PRI/Channelized T1 Daughter card (FC 2251) can be added to the base 4-port ISDN PRI/Channelized T1/J1 adapter (which produces a total of 8 ports on a single adapter).

- **One** 4-port ISDN PRI/Channelized (E1 interface) adapter (FC 2298)

**One** 4-port ISDN PRI/Channelized E1 Daughter card (FC 2252) can be added to the base 4-port ISDN PRI/Channelized E1 adapter (which produces a total of 8 ports on a single adapter).

- **Four** ISDN adapters (FC 2283 or FC 2292)

A maximum of 8 ISDN interfaces are allowed. Four can be FC 2283 or 2292.

**Note:** You can configure a 2216 with as many high-speed adapters (FDDI FC 2286, 10/100-Mbps Ethernet FC 2288, and HSSI FC 2289) as desired; however, you may not be able to achieve full media throughput concurrently on all the adapters. When planning for installation, review system performance expectations with an IBM representative.

Adapters can be installed in any of the eight adapter slots with the following restrictions:

1. If the 2-port Token-Ring (FC 2280) or 2-port Ethernet (FC 2281) adapter is plugged into slot 3 and active, then slot 4 cannot be used.
2. If the 2-port Token-Ring (FC 2280) or 2-port Ethernet (FC 2281) is plugged into slot 4 and active, then slot 3 cannot be used.
3. If the 2-port Token-Ring (FC 2280) or 2-port Ethernet (FC 2281) adapter is plugged into slot 7 and active, then slot 8 cannot be used.
4. If the 2-port Token-Ring (FC 2280) or 2-port Ethernet (FC 2281) adapter is plugged into slot 8 and active, then slot 7 cannot be used.



---

## Appendix F. Common Tasks for the 2216 Model 400 or Network Utility

This appendix provides questions and answers dealing with common installation, operation, and maintenance tasks, with suggestions as to where to find further help in performing them.

---

### LED States / Adapter Status

**Question** How do I check the state of the adapters in my 2216 Model 400 or Network Utility?

**Answer** The LED states on the front of the adapters indicate the status of the adapter. (See “Adapter Card Status” on page 1-3 and “Adapter Card Status” on page 2-2.)

---

### Firmware Interface

**Question** What is the firmware interface? How do I access it?

**Answer** The firmware is the microcode lying underneath the operational code that is running on the 2216 Model 400 or Network Utility. It is used primarily by service personnel in problem determination. The firmware is accessed by stopping the boot process with the **F1** key. The firmware menu contains a number of options.

You must have a VT220 terminal with the following settings: 19.2 Kbps, 8-N-1 for parity, data bits, and stop bits. You can use a null-modem cable for local access or a modem attachment for remote access. See “Access Methods” on page 7-1 for more information.

---

### Command Line Interface

**Question** How do I access the command line interface (the operational code) from within the firmware?

**Answer** From within the **firmware menu system** (System Management Services), press **F9**. The \* prompt is displayed after the system boots.

The command line interface is described in the *Multiprotocol Access Services Software User's Guide*.

---

### Navigating Through the Command Line Interface

**Question** How do I use the commands in the Command Line Interface?

**Answer** The structure of the interface is shown in Figure F-1 on page F-2.

The *Multiprotocol Access Services Software User's Guide* describes the entire command line interface. The basic prompts that you use are the:

- \* prompt, which is the OPERating CONsole (OPCON) prompt, the initial entry point to the command line interface
- Config> prompt, which is used for configuration changes

- + prompt, which is known as monitoring or GWCON.

The basic commands are:

- Type **?** and press **Enter** at any time to view a list of possible commands.
- Type **exit** and press **Enter** to return to the + prompt and to the Config> prompt.
- Press the **Ctrl-p** keys to return to the \* prompt.

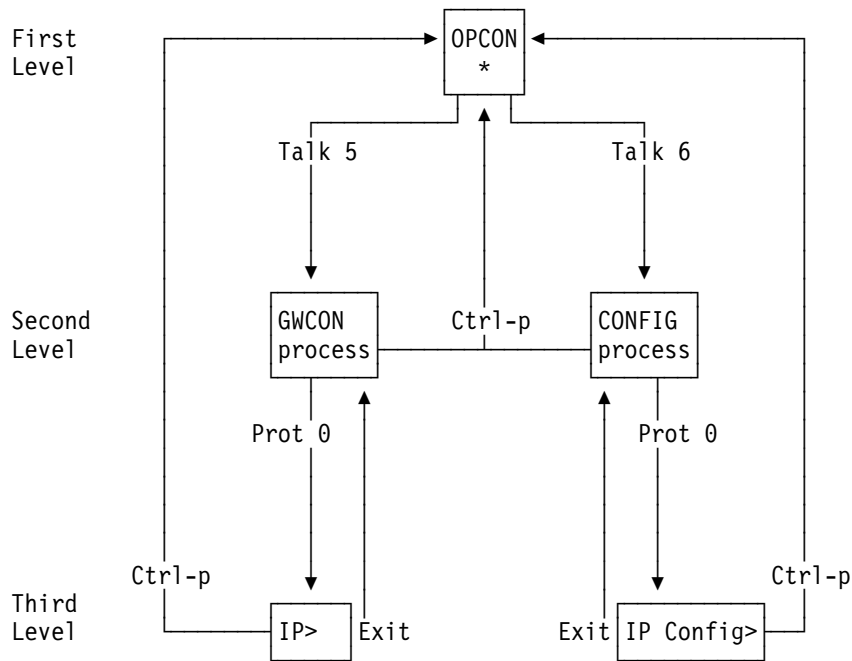

Figure F-1. Structure of the Command Line Interface (with the protocol command as an example)

## Displaying List of Configured Interfaces

**Question** How do I display a list of active interfaces?

**Answer**

1. Access the command line interface (the \* prompt).
2. Type **talk 6** and press **Enter** twice to reach the Config> prompt.
3. Enter **list dev**.
4. Press **Ctrl-p** to return to the OPCON (\*) prompt.

---

## Displaying the Operational State of the Interfaces

**Question** How do I display the state (up, down, disabled, etc.) of an interface?

**Answer**

1. Access the command line interface (the \* prompt).
2. Type **talk 5** and press **Enter** twice to reach the + (monitoring) prompt.
3. Enter **configuration**.
4. Press **Ctrl-p** to return to the OPCON (\*) prompt.

---

## Verifying Connectivity

**Question** How do I verify that a given IP address is online?

**Answer**

1. Access the command line interface (the \* prompt).
2. Type **talk 5** and press **Enter** twice to reach the + prompt.
3. Type **protocol** and press **Enter**.
4. Type **ip** and press **Enter**. The prompt changes to IP>.
5. Type **ping IP address value** and press **Enter**. Press **Enter** to stop the ping process.
6. Type **exit** at the IP> prompt and press **Enter**. The prompt changes to +.
7. Press **Ctrl-p** to return to the OPCON (\*) prompt.

---

## Viewing Vital Software Data

**Question** How do I view vital software data?

**Answer**

1. At the \* prompt, type **talk 6** and press **Enter** twice. The Config> prompt appears.
2. Enter **boot**.
3. Enter **describe**. The vital software data is displayed.
4. Press **Ctrl-p** to return to the OPCON (\*) prompt.

---

## Viewing Vital Hardware Data

**Question** How do I view vital hardware data?

**Answer**

1. Access the firmware main menu: During boot-up, press **F1** at the Prematurely terminate boot sequence prompt.
2. Select **4. Utilities**.
3. Select **9. View or Set Vital Product Data**.
4. Select **Hardware Vital Product Data**. The vital hardware data is displayed.
5. Return to the firmware main menu.
6. Press **F9** to load the operational code.

---

## Adding an Adapter at Initial Configuration

**Question** How do I add an adapter to the software configuration when I am creating the initial configuration?

**Answer** First, perform installation of the 2216 Model 400 or Network Utility and install any additional adapters.

- When you install a 2216 Model 400 or Network Utility, you need to create a software configuration.
- The operational code will put you at the configuration (Config only>) prompt.

1. Enter **add device** *type of device*.

**Note:** The steps create only the interface. You still have to use the **net** command to configure characteristics unique to that interface (for example, T/R, Ethernet, PPP, FR, SDLC, X.25). You also need to use the **protocol** command to configure protocols on the interface.

For example, **add device token**, or **add device ?** to see a list of device choices.

2. Enter the device slot number (1–x).
3. If you are adding an interface on a single-port adapter, continue with step 4 on page F-5. Otherwise, continue with this step.

Enter the port number (0–7, depending on the type of adapter).

The range of port numbers supported depends on the multi-port adapter type:

- For the Token-Ring (FC 2280) and Ethernet (FC 2281) adapters, port numbers 1 and 2 are supported.
- For the 8-port EIA-232E/V.24 (FC 2282) and 8-port X.21 adapters, port numbers 0–7 are supported.
- For the 6-port V.35/V.36 (FC 2290) adapter, port numbers 0–5 are supported.

4. Make a note of the interface number to which this port is assigned and the net number.

Repeat steps 1 to 4 if you have a multi-port adapter and you want to have more than one interface defined on that adapter.

Write the changes to save the configuration.

Reload the 2216 Model 400 or Network Utility to make the configuration changes active.

---

## Adding an Adapter after Initial Configuration

**Question** How do I add an adapter to the configuration after the 2216 Model 400 or Network Utility has been initially configured, without rebooting the 2216 Model 400 or Network Utility?

**Answer** First, your currently active configuration must have spare interfaces defined. If it does not, you must configure some spare interfaces and reboot one time before you can use the procedure. Configure spare interfaces using the **set spare** command. Refer to the “Configuring Spare Interfaces” heading in the *Multiprotocol Access Services Software User’s Guide* for more information and restrictions on this function. With a configuration active with spare interfaces, proceed with hardware installation of the adapter. Then configure the adapter as follows:

1. Access the command line interface (\* prompt).
2. Type **talk 6** and press **Enter** twice to reach the Config> prompt.
3. Enter **add device** *type of device*.

For example, **add device x21**, or **add device ?** to see a list of device choices.

If you are adding a dial-circuit device, go to step 6. Otherwise, continue with step 4

4. Enter the device slot number (1–x).
5. If you are adding an interface on a single-port adapter, go to step 6. Otherwise, continue with this step.

Enter the port number (0–7, depending on the type of adapter).

The range of port numbers supported depends on the multi-port adapter type:

- For the Token-Ring (FC 2280) and Ethernet (FC 2281) adapters, port numbers 1 and 2 are supported.
  - For the 8-port EIA-232E/V.24 (FC 2282) and 8-port X.21 adapters, port numbers 0–7 are supported.
  - For the 6-port V.35/V.36 (FC 2290) adapter, port numbers 0–5 are supported.
6. Make a note of the interface number to which this port is assigned and the net number.
  7. Enter **net** *net number* to enable you to configure interface-unique characteristics.
  8. Enter **exit** after configuring the interface.

9. Use the **protocol** command and **feature** command to configure protocols and features on the interface.
10. Enter **write** to save your changes.
11. Press **Ctrl-p** to return to the OPCON (\*) prompt.
12. Use the **activate** command within **talk 5** to bring the new interface online to the network without rebooting the box. There are restrictions to this capability. See “Configuring Spare Interfaces” in the *Multiprotocol Access Services Software User’s Guide*.

---

## Running Quick Configuration

**Question** How do I run the Quick Configuration program?

**Answer** First, make sure each adapter has been “added” (see “Adding an Adapter at Initial Configuration” on page F-4). Then, at the Config (only) or Config> prompt, enter **qc**.

---

## Disabling an Adapter Port

**Question** How do I disable a configured adapter port to remove the adapter from the software configuration?

**Answer**

1. Access the command line interface (\* prompt).
2. Type **talk 6** and press **Enter** twice to reach the Config> prompt.
3. Enter **list device**.
4. Make a note of the interface number of the adapter you wish to disable.
5. Enter **disable interface** *interface number*.
6. Enter **write** to save your changes. During the next time that you reboot, the configuration changes become active.

For details of this procedure, refer to the *Multiprotocol Access Services Software User’s Guide*.

---

## Enabling an Adapter Port

**Question** How do I enable a configured adapter port that was disabled using **disable interface** (in “Disabling an Adapter Port”)?

**Answer** Use this procedure to enable the port the next time that you reboot.

1. Access the command line interface (\* prompt).
2. Type **talk 6** and press **Enter** twice to reach the Config> prompt.
3. Enter **list device**.
4. Make a note of the interface number of the adapter you wish to enable.
5. Enter **enable interface** *interface number*.
6. Enter **write** to save your changes. During the next time that you reboot, the configuration changes become active.

For details of this procedure, refer to the *Multiprotocol Access Services Software User’s Guide*.

---

## Disabling an Adapter Slot

**Question** How do I disable all the configured ports on an adapter to remove the adapter from the software configuration?

**Answer**

1. Access the command line interface (\* prompt).
2. Type **talk 5** and press **Enter** twice to reach the + prompt.
3. Enter **int**.
4. Make a note of the slot number of the adapter you wish to disable.
5. Enter **disable slot** *slot number*.

The interfaces are disabled immediately.

For details of this procedure, refer to the *Multiprotocol Access Services Software User's Guide*.

---

## Enabling an Adapter Slot

**Question** How do I enable all the configured ports on an adapter that was disabled using **disable slot** (in "Disabling an Adapter Slot")?

**Answer**

1. Access the command line interface (\* prompt).
2. Type **talk 5** and press **Enter** twice to reach the + prompt.
3. Enter **int**.
4. Make a note of the slot number of the adapter you wish to enable.
5. Enter **enable slot** *slot number*.

The adapter interfaces begin their self-test and bringup procedures.

For details of this procedure, refer to the *Multiprotocol Access Services Software User's Guide*.

---

## Suspending Traffic on an Adapter Port

**Question** How do I disable a configured adapter port to remove or test an adapter?

**Answer**

1. Access the command line interface (\* prompt).
2. Type **talk 5** and press **Enter** twice to reach the + prompt.
3. Enter the **configuration** command.
4. Make a note of the interface net number of the adapter that you want to disable.
5. Enter **disable interface** *interface net number*.
6. Press the **Ctrl-p** keys to return to the \* prompt.

---

## Resuming Traffic on an Adapter Port

**Question** How do I enable a configured adapter port (that was disabled using the **talk 5 disable** command in "Suspending Traffic on an Adapter Port") to resume traffic?

## Answer

1. Access the command line interface (\* prompt).
2. Type **talk 5** and press **Enter** twice to reach the + prompt.
3. Enter the **configuration** command.
4. Make a note of the interface number of the adapter you wish to enable.
5. Enter **test interface number**.

**Note:** If you use the **test** command to enable an interface that has been configured at the Config> prompt (from **talk 6**) as disabled, the interface will be disabled again when you reboot.

Therefore, you should also use the Config> **enable interface** command to ensure that the interface is enabled the next time a reboot does occur.

For details of this procedure, refer to the *Multiprotocol Access Services Software User's Guide*.

---

## Removing and Deleting an Adapter

**Question** How do I remove and delete an adapter from the configuration?

### Answer

1. Access the command line interface (\* prompt).
2. Type **talk 6** and press **Enter** twice to reach the Config> prompt.
3. Enter **list device**.
4. Write down the interface number of the adapter that you wish to delete.

**Note:** If you are removing a multi-port adapter, then you need to record the interface number of all interfaces configured for that adapter.

5. Enter **delete interface interface number**.
6. At the Are you sure? prompt, enter **y**.
7. Enter **write** to save your changes.
8. Reload the 2216 Model 400 or Network Utility to make the configuration changes active.

For details of this procedure, refer to the *Multiprotocol Access Services Software User's Guide*.

---

## Up-to-Date Product Information

**Question** How can I find out the most current information about the 2216 Model 400 or Network Utility?

**Answer** Point your web browser to:  
<http://www.networking.ibm.com/216/216prod.html> for 2216 information,  
or to <http://www.networking.ibm.com> for general product information.



---

## Disabling Interfaces that Have WAN Reroute Enabled

**Question** How do I ensure that WAN Reroute does not try to automatically enable an alternate interface that is on an adapter about to be removed?

**Answer**

1. Access the command line interface (\* prompt).
2. Type **talk 5** and press **Enter** twice to reach the + (monitoring) prompt.
3. Type **disable slot slot#** or **disable interface#** for each interface on the adapter. For example:

```
+ disable slot 2
```

```
Interface 2 is enabled as a WAN Reroute alternate circuit and should be disabled as an alternate circuit if you will be removing the adapter
```

```
Do you want to disable WAN Reroute on this interface? (Yes, No): [No] Yes
```

```
Interface 2 has been disabled as a WAN Reroute alternate circuit
```

```
(adapter is removed and replaced)
```

---

## Enabling WAN Reroute after You Have Disabled it

**Question** How do I enable WAN Reroute to automatically enable an alternate interface that is on an adapter that has been replaced?

**Answer**

1. Access the command line interface (the \* prompt).
2. Type **talk 5** and press **Enter** twice to reach the + (monitoring) prompt.
3. Type **enable slot slot#** to start a self-test for each interface on the adapter **or** type **test interface#** for each interface that you want to bring up.

If you start a self-test for an alternate interface and the self-test is successful, the alternate interface will remain up even though it may not be needed to back-up a primary interface. If this happens, you can issue the **talk 5 disable interface#** command to put the alternate interface back into the standby (disabled) state.

The following is a sample:

```
+ enable slot 2
```

```
Interface 2 is configured as a WAN Reroute alternate circuit.
```

```
Do you want to enable WAN Reroute on this interface? (Yes, No):[No] Yes
```

```
Interface 2 is enabled as a WAN Reroute alternate circuit.
```

```
Are you sure that you want to test this interface? (Yes, No): [No] Yes
```

```
Testing net 4 ATM/0...successful
```

```
+
```

---

## Remote File Download

**Question** How do I download a configuration file to the 2216 Model 400 or Network Utility using the Firmware Menu System?

**Answer** Use the Systems Management Services.

1. Using a local console, select **4. Disable Unattended Mode** from the Systems Management Utilities menu in the firmware to put the 2216 Model 400 or Network Utility in ATTENDED mode. (Be sure to remember the password.)
2. To put the 2216 Model 400 or Network Utility into the correct monitor mode for the remote console that is going to be used, reboot the 2216 Model 400 or Network Utility and enter **Y** at the DO YOU WANT TO CHANGE THE MONITOR TYPE? prompt. Select the number next to the option for the Monitor type.
3. Remove the local console connection and reboot the 2216 Model 400 or Network Utility again. Do a hardware reset to put the 2216 Model 400 or Network Utility in ATTENDED mode. (Do not use the **reload** command.)
4. Wait at least 90 seconds for the 2216 Model 400 or Network Utility to reach the POWER-ON PASSWORD prompt after rebooting before attempting to remotely connect to the 2216 Model 400 or Network Utility.
5. Dial in to the 2216 Model 400 or Network Utility's PCMCIA modem with a TTY console. The console settings must be:
  - Speed = 19200 bps
  - Data bits = 8
  - Parity = No
  - Stop bits = 1
6. Once the connection is established, type the password and press **Enter**. The password will not be displayed, but you should get an \* on your screen for every character that you enter.
7. Press **F1** to terminate the boot sequence and enter the firmware Systems Management Services menu.
8. Select **4. Utilities** from the Systems Management Services menu.
9. Select **12. Change Management** from the Systems Management Utilities menu.
10. To download using a MODEM continue with this step: The Configuration file must be on remote console, but no IP addresses are needed.

To download using the TFTP, go to step 11 on page F-11.

  - a. Select **12. Xmodem software** from the Change Management Software Control menu.
  - b. Select **1. Config** from the Select Type dialog box.
  - c. Select the Bank to send the configuration file to from the Select Bank dialog box.

- d. Select the config # to send the configuration file to from the Select Config dialog box.
  - e. When the BEGIN FILE TRANSFER dialog box closes, use your Xmodem software to transfer the files. For example, with PROCOMM:
    - Press the PAGE UP key when the dialog box disappears.
    - Press X for xmodem mode.
    - Type in the path and file name of the configuration you are going to transfer to the 2216.
    - Press ENTER.
11. To download using TFTP: You must have a PCMCIA networking card in the PCMCIA slot before booting the 2216 Model 400 or Network Utility and be connected to a network that has the configuration file you are going to transfer to the 2216 Model 400 or Network Utility.
- Note:** IP addresses need to be set up on the PCMCIA slot using the System Management Utilities menu and select **11. Remote Initial Program Load Setup** before a TFTP can be done.
- a. Select **10. TFTP software** from the Change Management Software Control menu.
  - b. Select **1. Config** from the Select Type dialog box.
  - c. Select the Bank to send the configuration file to from the Select Bank dialog box.
  - d. Select the config # to send the configuration file to from the Select Config dialog box.
  - e. Type in the path and name of the Configuration file that will be downloaded onto the 2216 Model 400 or Network Utility and press **Enter**.

---

## Spare Interfaces

**Question** Can I move traffic from a defective adapter to another adapter without restarting the 2216 Model 400 or Network Utility?

**Answer** Yes. Use the spare interface function. See "Configuring Spare Interfaces" in the *Multiprotocol Access Services Software User's Guide*.

---

## Configuring IP Addresses for a PCMCIA LAN Adapter

**Question** How do I configure IP addresses for a PCMCIA LAN adapter on a Network Utility?

**Answer** To configure the PCMCIA LAN adapter:

- From the command line:
  1. At the OPCON prompt (\*), type **talk 6** and press **Enter**.
  2. At the Config> prompt, type **system set ip** and press **Enter**.

3. Enter addresses and information for the client, server, gateway, and subnet mask.
  4. At the `Config>` prompt, type **system display ip** and press **Enter** to view the addresses for the PCMCIA LAN adapter.
- From the firmware:
    1. Access the firmware (see “Starting Firmware” on page 8-2)
    2. Select the **Utilities** option
    3. Select the **Remote Initial Program Load Setup** option
    4. Select the **IP Parameters** option
    5. Enter addresses and information for the client, server, gateway, and subnet mask
    6. Press **Enter** to save the information that you entered
    7. Select the **Ping** option to see if you can communicate with the adapter
    8. Select the **PCMCIA** option
    9. Select the **Server Address** option
    10. Press **Enter** to save your changes
    11. Wait for *change successful* message

---

## Appendix G. Notices

References in this publication to IBM products, programs, or services do not imply that IBM intends to make these available in all countries in which IBM operates. Any reference to an IBM product, program, or service is not intended to state or imply that only IBM's product, program, or service may be used. Subject to IBM's valid intellectual property, or other legally protectable rights, any functionally equivalent product, program, or service that does not infringe any of IBM's intellectual property rights may be used instead of the IBM product, program, or service. The evaluation and verification of operation in conjunction with other products, except those expressly designated by IBM, are the user's responsibility.

IBM may have patents or pending patent applications covering subject matter in this document. The furnishing of this document does not give you any license to these patents. You can send license inquiries, in writing, to:

IBM Director of Licensing  
IBM Corporation  
North Castle Drive  
Armonk, NY 10504-1785 U.S.A

---

### Notice to Users of Online Versions of This Book

For online versions of this book, we authorize you to:

- Copy, modify, and print the documentation contained on the media, for use within your enterprise, provided you reproduce the copyright notice, all warning statements, and other required statements on each copy or partial copy.
- Transfer the original unaltered copy of the documentation when you transfer the related IBM product (which may be either machines you own, or programs, if the program's license terms permit a transfer). You must, at the same time, destroy all other copies of the documentation.

You are responsible for payment of any taxes, including personal property taxes, resulting from this authorization.

THERE ARE NO WARRANTIES, EXPRESS OR IMPLIED, INCLUDING THE WARRANTIES OF MERCHANTABILITY AND FITNESS FOR A PARTICULAR PURPOSE.

Some jurisdictions do not allow the exclusion of implied warranties, so the above exclusion may not apply to you.

Your failure to comply with the terms above terminates this authorization. Upon termination, you must destroy your machine-readable documentation.

---

## Electronic Emission Notices

### *Federal Communications Commission (FCC) Class A Statement*

**Note:** This equipment has been tested and found to comply with the limits for a Class A digital device, pursuant to Part 15 of the FCC Rules. These limits are designed to provide reasonable protection against harmful interference when the equipment is operated in a commercial environment. This equipment generates, uses, and can radiate radio frequency energy and, if not installed and used in accordance with the instruction manual, may cause harmful interference to radio communications. Operation of this equipment in a residential area is likely to cause harmful interference, in which case the user will be required to correct the interference at his own expense.

Properly shielded and grounded cables and connectors must be used in order to meet FCC emission limits. IBM is not responsible for any radio or television interference caused by using other than recommended cables and connectors or by unauthorized changes or modifications to this equipment. Unauthorized changes or modifications could void the user's authority to operate the equipment.

This device complies with Part 15 of the FCC Rules. Operation is subject to the following two conditions: (1) this device may not cause harmful interference, and (2) this device must accept any interference received, including interference that may cause undesired operation.

## Industry Canada Class A Emission Compliance Statement

This Class A digital apparatus complies with Canadian ICES-003.

## Avis de conformité aux normes d'Industrie Canada

Cet appareil numérique de la classe A est conforme à la norme NMB-003 du Canada.

## Japanese Voluntary Control Council for Interference (VCCI) Statement

This product is a Class A Information Technology Equipment and conforms to the standards set by the Voluntary Control Council for Interference by Technology Equipment (VCCI). In a domestic environment this product may cause radio interference in which case the user may be required to take adequate measures.

この装置は、情報処理装置等電波障害自主規制協議会（VCCI）の基準に基づくクラスA情報技術装置です。この装置を家庭環境で使用すると電波妨害を引き起こすことがあります。この場合には使用者が適切な対策を講ずるよう要求されることがあります。

## CISPR22 Compliance Statement

This product has been tested and found to comply with the limits for Class A Information Technology Equipment according to CISPR 22/European Standard EN 55022. The limits for Class A equipment were derived for commercial and industrial environments to provide reasonable protection against interference with licensed communication equipment.

**Warning:** This is a Class A product. In a domestic environment this product may cause radio interference in which case the user may be required to take adequate measures.

## Taiwanese Class A Warning Statement

警告使用者：  
這是甲類的資訊產品，在  
居住的環境中使用時，可  
能會造成射頻干擾，在這  
種情況下，使用者會被要  
求採取某些適當的對策。

## EMC Directive 89/336/EEC Statement

This product is in conformity with the protection requirements of EC Council Directive 89/336/EEC on the approximation of the laws of the Member States relating to electromagnetic compatibility. IBM cannot accept responsibility for any failure to satisfy the protection requirements resulting from a non-recommended modification of the product, including the fitting of non-IBM option cards.

The product (2216 Model 400) bears the Telecom CE mark (CE 168 X) for ISDN Basic Rate complying with I-CTR3 (Bridging measures) as per the European directive 91/263/EEC (TTE directive). The product bears the Telecom CE mark (CE 168 X) for: V.24/V.28,V36 and X.21 electrical interfaces complying with NET 1 and with NET 2 physical level. ISDN Basic Rate complying with I-CTR3 (Bridging measures) as per the European directive 91/263/EEC (TTE directive).

**Warning:** This is a Class A product. In a domestic environment this product may cause radio interference in which case the user may be required to take adequate measures.

**Zulassungsbescheinigung laut dem Deutschen Gesetz über die elektromagnetische Verträglichkeit von Geräten (EMVG) vom 30. August 1995 (bzw. der EMC EG Richtlinie 89/336)**

Dieses Gerät ist berechtigt in Übereinstimmung mit dem Deutschen EMVG das EG-Konformitätszeichen - CE - zu führen.

Verantwortlich für die Konformitätserklärung nach Paragraph 5 des EMVG ist die IBM Deutschland Informationssysteme GmbH, 70548 Stuttgart.

Informationen in Hinsicht EMVG Paragraph 3 Abs. (2) 2:

Das Gerät erfüllt die Schutzanforderungen nach EN 50082-1 und EN 55022 Klasse A.

EN 55022 Klasse A Geräte müssen mit folgendem Warnhinweis versehen werden: "Warnung: dies ist eine Einrichtung der Klasse A. Diese Einrichtung kann im Wohnbereich Funkstörungen verursachen; in diesem Fall kann vom Betreiber verlangt werden, angemessene Maßnahmen durchzuführen und dafür aufzukommen."

EN 50082-1 Hinweis: "Wird dieses Gerät in einer industriellen Umgebung betrieben (wie in EN 50082-2 festgelegt), dann kann es dabei eventuell gestört werden. In solch einem Fall ist der Abstand bzw. die Abschirmung zu der industriellen Störquelle zu vergrößern."

Anmerkung: Um die Einhaltung des EMVG sicherzustellen sind die Geräte, wie in den IBM Handbüchern angegeben, zu installieren und zu betreiben.

## Telecommunication Notices

### FCC Part 68 Compliance Information:

Features and optional adapters for the IBM 2216 comply with Part 68 of the FCC rules. The label included on the adapter tray contains, among other information, the FCC registration number and Ringer Equivalence Number (REN), if applicable for this equipment. If requested, provide this information to your telephone company.

The features and adapters included are:

1-Port ISDN PRI (T1/J1) Adapter LIC 283 with interface code 04DU9-1SN, service code 6.0N and jack type RJ48C.

4-port ISDN PRI/Channelized (T1/J1) Daughter Card with interface code 04DU9-1SN, service code 6.0N and jack type RJ48C.

The REN is useful to determine the quantity of devices you may connect to your telephone line and still have those devices ring when your number is called. In most, but not all areas, the sum of the RENs of all devices should not exceed five (5.0). To be certain of the number of devices you may connect to your line, as determined by the REN, you should call your local telephone company to determine the maximum REN for your calling area.

If the IBM 2216 causes harm to the telephone network, the Telephone Company may discontinue your service temporarily. If possible, they will notify you in advance. But if advance notice isn't practical, you will be notified as soon as possible. You will be advised of your right to file a complaint with the FCC.

Your telephone company may make changes in its facilities, equipment, operations, or procedures that could affect the proper operation of your equipment. If they do, you will be given advance notice so as to give you an opportunity to maintain uninterrupted service.

If trouble is experienced with this equipment, for repair or warranty information, in the United States, call IBM at **1-800-IBM-SERV**. In Canada, call IBM at **1-800-465-6600**.

No repairs can be performed by the customer.



### **Industry Canada Information:**

NOTICE: The Industry Canada label identifies certified equipment. This certification means that the equipment meets certain telecommunications network protective, operational and safety requirements. Industry Canada does not guarantee the equipment will operate to the user's satisfaction.

Before installing this equipment, users should ensure that it is permissible to be connected to the facilities of the local telecommunications company. The equipment must also be installed using an acceptable method of connection. In some cases, the company's inside wiring associated with a single line individual service may be extended by means of a certified connector assembly (telephone extension cord). The customer should be aware that compliance with the above conditions may not prevent degradation of service in some situations.

Repairs to certified equipment should be made by an authorized Canadian maintenance facility designated by the supplier. Any repairs or alterations made by the user to this equipment, or equipment malfunctions, may give the telecommunications company cause to request the user to disconnect the equipment.

Users should ensure for their own protection that the electrical ground connections of the power utility, telephone lines and internal metallic water pipe system, if present, are connected together. This precaution may be particularly important in rural areas.

CAUTION: Users should not attempt to make such connections themselves, but should contact the appropriate electrical inspection authority, or electrician, as appropriate.

AVIS : L'étiquette d'Industrie Canada permet d'identifier un équipement homologué. Cette homologation signifie que cet équipement satisfait certaines exigences en matière de protection, d'exploitation et de sécurité du réseau de télécommunications. Industrie Canada n'offre aucune garantie que le fonctionnement de cet équipement soit à la satisfaction de l'utilisateur.

Avant d'installer cet équipement, l'utilisateur doit s'assurer qu'il a la permission de le raccorder aux installations de l'entreprise de télécommunications. L'installation de cet équipement doit aussi se faire selon un mode de raccordement acceptable. Dans certains cas, le câblage interne de l'entreprise associé au service individuel offert par une ligne d'abonné peut être prolongé au moyen d'un connecteur homologué (prolongateur de téléphone). Le client devrait être informé que la conformité de son équipement aux conditions susmentionnées n'est pas une prévention contre la dégradation du service dans certaines situations.

Toute réparation d'un équipement homologué devrait être effectuée par un service de maintenance canadien autorisé qui a été désigné par le fournisseur. Toute réparation ou modification d'équipement faite par l'utilisateur, ou tout mauvais fonctionnement, pourrait entraîner la déconnexion de cet équipement par l'utilisateur à la demande de l'entreprise de télécommunications.

Pour sa protection personnelle, l'utilisateur devrait s'assurer que les mises à la terre des services publics électriques, des lignes téléphoniques et du système interne des canalisations d'eau à tuyaux métalliques, advenant leur présence, sont

interconnectées. Dans les zones rurales, il s'agit-là d'une précaution particulièrement importante à prendre.

ATTENTION : Toute tentative de connexion par l'utilisateur est à déconseiller. Il est préférable de communiquer avec le responsable de l'inspection en électricité ou un électricien, selon le cas.

### United Kingdom Compliance Statement

STATEMENT OF COMPLIANCE

The United Kingdom Telecommunications Act 1984. This equipment is approved under  
General Approval Number NS/G/1234/J/100003

for indirect connections to the public telecommunications systems in the United  
Kingdom.

---

## Trademarks

The following terms are trademarks of the IBM Corporation in the United States or other countries or both:

|          |                  |                     |
|----------|------------------|---------------------|
| AIX      | Nways            | Presentation Manger |
| eNetwork | NetView          | VM/ESA              |
| ESCON    | OS/2             |                     |
| IBM      | Parallel Sysplex |                     |

Tivoli is a trademark of Tivoli Systems Inc. United States and/or other countries.

Java and all Java-based trademarks and logos are trademarks or registered trademarks of Sun Microsystems, Inc. in the United States and/or other countries.

Microsoft, Windows, Windows NT, and the Windows logo are trademarks of Microsoft Corporation in the United States and/or other countries.

Other company, product, and service names may be trademarks or service marks of others.

---

## Appendix H. Safety Information

 **Danger:** Before you begin to install this product, read the safety information in *Caution: Safety Information—Read This First*, SD21-0030. This booklet describes safe procedures for cabling and plugging in electrical equipment.

 **Gevaar:** Voordat u begint met de installatie van dit produkt, moet u eerst de veiligheidsinstructies lezen in de brochure *PAS OP! Veiligheidsinstructies—Lees dit eerst*, SD21-0030. Hierin wordt beschreven hoe u elektrische apparatuur op een veilige manier moet bekabelen en aansluiten.

 **Danger:** Avant de procéder à l'installation de ce produit, lisez d'abord les consignes de sécurité dans la brochure *ATTENTION: Consignes de sécurité—A lire au préalable*, SD21-0030. Cette brochure décrit les procédures pour câbler et connecter les appareils électriques en toute sécurité.

 **Perigo:** Antes de começar a instalar este produto, leia as informações de segurança contidas em *Cuidado: Informações Sobre Segurança—Leia Isto Primeiro*, SD21-0030. Esse folheto descreve procedimentos de segurança para a instalação de cabos e conexões em equipamentos elétricos.



危險：安裝本產品之前，請先閱讀  
"Caution: Safety Information--Read  
This First" SD21-0030 手冊中所提  
供的安全注意事項。這本手冊將會說明  
使用電器設備的纜線及電源的安全程序。



Opasnost: Prije nego što počnete sa instalacijom produkta, pročítajte naputak o pravilima o sigurnom rukovanju u  
Upozorenje: Pravila o sigurnom rukovanju - Prvo pročítaj ovo, SD21-0030. Ovaj priručnik opisuje sigurnosne postupke za priključivanje kabela i priključivanje na električno napajanje.





**Upozornění:** než zahájíte instalaci tohoto produktu, přečtěte si nejprve bezpečnostní informace v pokynech „Bezpečnostní informace“ č. 21-0030. Tato brožurka popisuje bezpečnostní opatření pro kabeláž a zapojení elektrického zařízení.





**Fare!** Før du installerer dette produkt, skal du læse sikkerhedsforskrifterne i *NB: Sikkerhedsforskrifter—Læs dette først* SD21-0030. Vejledningen beskriver den fremgangsmåde, du skal bruge ved tilslutning af kabler og udstyr.

 **Gevaar** Voordat u begint met het installeren van dit produkt, dient u eerst de veiligheidsrichtlijnen te lezen die zijn vermeld in de publikatie *Caution: Safety Information - Read This First*, SD21-0030. In dit boekje vindt u veilige procedures voor het aansluiten van elektrische apparatuur.

 **VAARA:** Ennen kuin aloitat tämän tuotteen asennuksen, lue julkaisussa *Varoitus: Turvaohjeet—Lue tämä ensin*, SD21-0030, olevat turvaohjeet. Tässä kirjassessa on ohjeet siitä, miten sähkölaitteet kaapeloidaan ja kytketään turvallisesti.

 **Danger :** Avant d'installer le présent produit, consultez le livret *Attention : Informations pour la sécurité — Lisez-moi d'abord* SD21-0030, qui décrit les procédures à respecter pour effectuer les opérations de câblage et brancher les équipements électriques en toute sécurité.

 **Vorsicht:** Bevor mit der Installation des Produktes begonnen wird, die Sicherheitshinweise in *Achtung: Sicherheitsinformationen—Bitte zuerst lesen*, IBM Form SD21-0030. Diese Veröffentlichung beschreibt die Sicherheitsvorkehrungen für das Verkabeln und Anschließen elektrischer Geräte.

 **Vigyázat:** Mielőtt megkezdi a berendezés üzembe helyezését, olvassa el a *Caution: Safety Information— Read This First*, SD21-0030 könyvecskében leírt biztonsági információkat. Ez a könyv leírja, milyen biztonsági intézkedéseket kell megtenni az elektromos berendezés huzalozásakor illetve csatlakoztatásakor.

 **Pericolo:** prima di iniziare l'installazione di questo prodotto, leggere le informazioni relative alla sicurezza riportate nell'opuscolo *Attenzione: Informazioni di sicurezza — Prime informazioni da leggere* in cui sono descritte le procedure per il cablaggio ed il collegamento di apparecchiature elettriche.



危険： 導入作業を開始する前に、安全に関する小冊子SD21-0030 の「最初にお読みください」(Read This First)の項をお読みください。  
この小冊子は、電気機器の安全な配線と接続の手順について説明しています。



위험: 이 제품을 설치하기 전에 반드시 "주의: 안전 정보-시작하기 전에" (SD21-0030) 에 있는 안전 정보를 읽으십시오.



**Fare:** Før du begynner å installere dette produktet, må du lese sikkerhetsinformasjonen i *Advarsel: Sikkerhetsinformasjon — Les dette først*, SD21-0030 som beskriver sikkerhetsrutinene for kabling og tilkobling av elektrisk utstyr.



Uwaga:

Przed rozpoczęciem instalacji produktu należy zapoznać się z instrukcją: "Caution: Safety Information - Read This First", SD21-0030.

Zawiera ona warunki bezpieczeństwa przy podłączaniu do sieci elektrycznej i eksploatacji.



**Perigo:** Antes de iniciar a instalação deste produto, leia as informações de segurança *Cuidado: Informações de Segurança — Leia Primeiro*, SD21-0030. Este documento descreve como efectuar, de um modo seguro, as ligações eléctricas dos equipamentos.



**ОСТОРОЖНО:** Прежде чем устанавливать этот продукт, прочтите Инструкцию по технике безопасности в документе "Внимание: Инструкция по технике безопасности -- Прочсть в первую очередь", SD21-0030. В этой брошюре описаны безопасные способы каблирования и подключения электрического оборудования.



Nebezpečnostvo: Pred inštaláciou výrobku si prečítajte bezpečnosté predpisy v

Výstraha: Bezpečnosté predpisy - Prečítaj ako prvé, SD21-0030. V tejto brožúrke sú opísané bezpečnosté postupy pre pripojenie elektrických zariadení.



Pozor: Preden začnete z instalacijo tega produkta preberite poglavje: "Opozorilo: Informacije o varnem rokovanju-preberi pred uporabo," SD21-0030. To poglavje opisuje pravilne postopke za kabliranje,



**Peligro:** Antes de empezar a instalar este producto, lea la información de seguridad en *Atención: Información de Seguridad — Lea Esto Primero*, SD21-0030. Este documento describe los procedimientos de seguridad para cablear y enchufar equipos eléctricos.



**Varning — livsfara:** Innan du börjar installera den här produkten bör du läsa säkerhetsinformationen i dokumentet *Varning: Säkerhetsföreskrifter— Läs detta först*, SD21-0030. Där beskrivs hur du på ett säkert sätt ansluter elektrisk utrustning.



危險：

開始安裝此產品之前，請先閱讀安全資訊。

注意：

請先閱讀 - 安全資訊 SD21-0030

此冊子說明插接電器設備之電纜線的安全程序。

---

## Model 400 Caution Notices

### CAUTION

A fully populated IBM 2216-400 weighs about 43.1 kg (95 lb).

### LET OP:

Als alle voorzieningen geïnstalleerd zijn, weegt de IBM 2216-400 ongeveer 43,1 kg.

### CUIDADO:

Um dispositivo IBM 2216-400 totalmente populado pesa cerca de 43,1 kg (95 lb).

### Pas på!

En fuldt udbygget IBM 2216-400 vejer ca. 43,1 kg.

### ATTENTION

Un IBM 2216-400 entièrement équipé pèse environ 43,1 kg.

### ACHTUNG

Eine voll bestückte IBM 2216-400 wiegt ungefähr 43.1 kg.

### ATTENZIONE:

Un IBM 2216-400 cui sono collegate tutte le unità pesa circa 43,1 kg.

### CUIDADO:

Um IBM 2216-400 totalmente preenchido pesa cerca de 43 kg.

### Precaució

Un IBM 2216-400 completamente equipado pesa alrededor de 43.1 kg (95 lb).

### VARNING:

En fullt utbyggd IBM 2216-400 väger ca 43 kg.

### ADVARSEL

En IBM 2216-400 som er fullt utstyrt, veier ca. 43 kg.

## **WAARSCHUWING**

Een volledig uitgeruste IBM 2216-400 weegt ongeveer 43 kg.

### **Varoitus**

IBM 2216-400 -laite painaa täydessä kokoonpanossaan noin 43 kiloa.

危険:

IBM 2216-400 は装備により約 43 kg の重さがあります。

### **POZOR:**

Plně osazená IBM 2216-400 váží zhruba 43,1 kg.

注意:

一完整配備的 IBM 2216-400 重量約是 43.1 公斤(95 磅)。

注意:

一台配置完整的 IBM 2216-400 重約 43.1 kg(95 lb)。

## **VIGYÁZAT!**

A teljesen kiépített IBM 2216-400 berendezés tömege kb. 43,1 kg (95 lb)

При полной комплектации IBM 2216-400 весит около 45 кг.

## **VÝSTRAHA**

Zariadenie IBM 2216-400 v plnej výbave váži cca 43.1 kg (95 lb).

## **UWAGA**

Całkowicie wypełnione urządzenie IBM 2216-400 waży około 43.1 kg.

## **OPOZORILO:**

Popolnoma opremljen IBM 2216-400 tehta okoli 43,1 kg (95 lb)

**UPOZORENJE:**  
Potpuno opremljen IBM 2216-400 teži oko 43,1 kg (95 lb)



---

# Glossary

This glossary includes terms and definitions from:

- The *IBM Dictionary of Computing* (New York; McGraw-Hill, Inc., 1994).
- The *American National Standard Dictionary for Information Systems*, ANSI X3.172-1990, copyright 1990 by the American National Standards Institute (ANSI). Copies may be purchased from the American National Standards Institute, 11 West 42nd Street, New York, New York 10036. Definitions are identified by the symbol (A) after the definition.
- The *Information Technology Vocabulary* developed by Subcommittee 1, Joint Technical Committee 1, of the International Organization for Standardization and the International Electrotechnical Commission (ISO/IEC JTC1/SC1). Definitions of published parts of this vocabulary are identified by the symbol (I) after the definition; definitions taken from draft international standards, committee drafts, and working papers being developed by ISO/IEC JTC1/SC1 are identified by the symbol (T) after the definition, indicating that final agreement has not yet been reached among the participating National Bodies of SC1.
- The Network Working Group Request for Comments: 1208.

The following cross-references are used in this glossary:

**Contrast with:** This refers to a term that has an opposed or substantively different meaning.

**Synonym for:** This indicates that the term has the same meaning as a preferred term, which is defined in its proper place in the glossary.

**Synonymous with:** This is a backward reference from a defined term to all other terms that have the same meaning.

**See:** This refers you to multiple-word terms that have the same last word.

**See also:** This refers you to terms that have a related, but not synonymous, meaning.

## A

A. Ampere.

ac. Alternating current.

**active.** (1) Operational. (2) Pertaining to a node or device that is connected or is available for connection to another node or device.

**Advanced Peer-to-Peer Networking (APPN) network node.** A node that offers a broad range of end-user services and that can provide the following:

- Distributed directory services, including registration of its domain resources to a central directory server
- Topology database exchanges with other APPN network nodes, enabling network nodes throughout the network to select optimal routes for LU-LU sessions based on requested classes of service
- Session services for its local LUs and client end nodes
- Intermediate routing services within an APPN network

**agent.** A system that assumes an agent role.

**analog.** (1) Pertaining to data consisting of continuously variable physical quantities. (A)  
(2) Contrast with *digital*.

**ANSI.** American National Standards Institute.

**AppleTalk.** A network protocol developed by Apple Computer, Inc. This protocol is used to interconnect network devices, which can be a mixture of Apple and non-Apple products.

**APPN node.** Advanced Peer-to-Peer Networking (APPN) node.

**asynchronous transfer mode (ATM).** A connection-oriented access service to transfer data, voice, and video on broadband networks at very high speeds. These traffic types are mixed together over the available link bandwidth rather than being isolated into dedicated chunks of bandwidth.

The current ATM is for speeds of 155 Mbps and 622 Mbps but it will be capable of speeds in range of gigabits per second.

ATM divides all traffic into fixed-length cells, each containing 48 bytes of user data and five bytes of overhead, and manages the flow of these cells through the network.

**ATM.** Asynchronous Transfer Mode.

**attachment unit interface (AUI).** In a local area network, the interface between the medium attachment unit and the data terminal equipment within a data station. (I) (A)

**AUI.** Attachment unit interface.

**autonomous system (AS).** A group of networks and routers that use the same interior gateway protocol and for which one administrative authority has responsibility.

## B

**Bc.** Committed burst size.

**Be.** Excess burst size.

**bps.** Bits per second.

**bridge.** A functional unit that interconnects multiple LANs (locally or remotely) that use the same logical link control protocol but that can use different medium access control protocols. A bridge forwards a frame to another bridge based on the medium access control (MAC) address.

**bridging.** In LANs, the forwarding of a frame from one LAN segment to another. The destination is specified by the medium access control (MAC) sublayer address encoded in the destination address field of the frame header.

**broadband.** A large frequency band allowing different kinds of transmissions, such as coded voice, video, and data, at the same time.

**BSC.** Binary synchronous communication.

## C

**CAS.** Channel associated signaling.

**CCITT.** International Telegraph and Telephone Consultative Committee. This was an organization of the International Telecommunication Union (ITU). On 1 March 1993 the ITU was reorganized, and responsibilities for standardization were placed in a subordinate organization named the Telecommunication Standardization Sector of the International Telecommunication Union (ITU-TS). "CCITT" continues to be used for recommendations that were approved before the reorganization.

**CCS.** (1) common channel signaling (2) change control server.

**CDB.** Configuration database.

**CES.** Circuit emulation service.

**channelization.** The process of breaking the bandwidth on a communication line into a number of channels, possibly of different size. Also called *time division multiplexing* (TDM).

**CIR.** Committed information rate.

**circuit.** (1) One or more conductors through which an electric current can flow. See *physical circuit* and *virtual circuit*. (2) A logic device.

**circuit switching.** (1) A process that, on demand, connects two or more data terminal equipment (DTEs) and permits the exclusive use of a data circuit between them until the connection is released. (I) (A) (2) Synonymous with *line switching*.

**CMIP.** Common Management Information Protocol.

**CMIS.** Common Management Information Services.

**CMOT.** CMIP over TCP/IP.

**CNM.** Communication network management.

**configuration.** (1) The manner in which the hardware and software of an information processing system are organized and interconnected. (T) (2) The devices and programs that make up a system, subsystem, or network.

**connection.** In data communication, an association established between functional units for conveying information. (I) (A)

**CP.** Control point.

**CRC.** Cyclic redundancy check.

**CU logical address.** The control unit (CU) address defined in the host for the 2216. This value is defined in the host Input/Output Configuration Program (IOCP) by the CUADD statement on the CNTLUNIT macro instruction. The control unit address must be unique for each logical partition defined on the same host.

## D

**DAS.** Dual-attaching system (for FDDI).

**data circuit.** (1) A pair of associated transmit and receive channels that provide a means of two-way data communication. (I) (2) See also *physical circuit* and *virtual circuit*.

### Notes:

1. Between data switching exchanges, the data circuit may include data circuit-terminating equipment (DCE), depending on the type of interface used at the data switching exchange.
2. Between a data station and a data switching exchange or data concentrator, the data circuit includes the data circuit-terminating equipment at the data station end, and may include equipment similar to a DCE at the data switching exchange or data concentrator location.

**data circuit-terminating equipment (DCE).** In a data station, the equipment that provides the signal conversion and coding between the data terminal equipment (DTE) and the line. (I)

**Notes:**

1. The DCE may be separate equipment or an integral part of the DTE or of the intermediate equipment.
2. A DCE may perform other functions that are usually performed at the network end of the line.

**data link control (DLC).** A set of rules used by nodes on a data link (such as an SDLC link or a token ring) to accomplish an orderly exchange of information.

**data link switching (DLSw).** A method of transporting network protocols that use IEEE 802.2 logical link control (LLC) type 2. SNA and NetBIOS are examples of protocols that use LLC type 2. See also *encapsulation* and *spoofing*.

**data terminal equipment (DTE).** That part of a data station that serves as a data source, data sink, or both. (I) (A)

**data terminal ready (DTR).** A signal to the modem used with the EIA 232 protocol.

**dc.** Direct current.

**DCD.** DC distribution (module).

**DCE.** Data circuit-terminating equipment.

**DC48.** DC power input type -48V.

**dependent LU requester (DLUR).** An APPN end node or an APPN network node that owns dependent LUs, but requests that a dependent LU server provide the SSCP services for those dependent LUs.

**device.** A mechanical, electrical, or electronic contrivance with a specific purpose.

**device address.** The unit address transmitted on the channel path to select a 2216 device. It is also referred to as subchannel number in S/370 I/O architecture. This value is defined in the host IOCP by the UNITADD statement on the CNTLUNIT macro instruction for the real device.

**digital.** (1) Pertaining to data that consist of digits. (T)  
(2) Pertaining to data in the form of digits. (A)  
(3) Contrast with *analog*.

**DIMM.** Dual inline memory module.

**DLCI.** Data link connection identifier.

**DLSw.** Data link switching.

**DLUR.** Dependent LU requester.

**DTE.** Data terminal equipment. (A)

**DTMF.** Dual-tone modulation frequency.

**DTR.** Data terminal ready.

**Dual inline memory module (DIMM).** A small circuit board with memory-integrated circuits containing signal and power pins on both sides of the board.

## E

**E&M.** Earth & mark.

**EIA.** Electronic Industries Association.

**EIA unit.** A unit of measure, established by the Electronic Industries Association, equal to 44.45 millimeters (1.75 inches).

**EIA 232.** In data communications, a specification of the Electronic Industries Association (EIA) that defines the interface between data terminal equipment (DTE) and data circuit-terminating equipment (DCE), using serial binary data interchange.

**Electronic Industries Association (EIA).** An organization of electronics manufacturers that advances the technological growth of the industry, represents the views of its members, and develops industry standards.

**EMIF.** ESCON Multiple Image Facility.

**encapsulation.** In communications, a technique used by layered protocols by which a layer adds control information to the protocol data unit (PDU) from the layer it supports. In this respect, the layer encapsulates the data from the supported layer. In the Internet suite of protocols, for example, a packet would contain control information from the physical layer, followed by control information from the network layer, followed by the application protocol data. See also *data link switching (DLSw)*.

**ESCD.** ESCON Director.

**ESCON.** Enterprise Systems Connection.

**ESF.** Extended status flags.

**Ethernet.** A 10-Mbps baseband local area network that allows multiple stations to access the transmission medium at will without prior coordination, avoids contention by using carrier sense and deference, and resolves contention by using collision detection and transmission. Ethernet uses carrier sense multiple access with collision detection (CSMA/CD).

**ELS.** Event Logging System

## F

**FANB.** Fan box.

**FasTR.** Fast Token Ring encapsulated in ATM.

**FAT.** File allocation table.

**fax.** Hardcopy received from a facsimile machine.  
Synonymous with *teletcopy*.

**FDDI.** Fiber distributed data interface (100 Mbps fiber optic LAN)

**FEP.** Front-end processor.

**flash memory.** A data storage device that is programmable, erasable, and does not require continuous power. The chief benefit of flash memory over other programmable and erasable data storage devices is that it can be reprogrammed without being removed from the circuit board.

**FR.** Frame relay.

**FRAD.** Frame relay access device.

**frame relay.** (1) An interface standard describing the boundary between a user's equipment and a fast-packet network. In frame-relay systems, flawed frames are discarded; recovery comes end-to-end rather than hop-by-hop. (2) A technique derived from the integrated services digital network (ISDN) D channel standard. It assumes that connections are reliable and dispenses with the overhead of error detection and control within the network.

**frequency.** The rate of signal oscillation, expressed in hertz.

**FRFH.** Frame relay frame handler.

**front-end processor (FEP).** A processor, such as the IBM 3745 or 3174, that relieves a main frame from the communication control tasks.

**FRTE.** Frame relay terminal equipment.

**FRU.** Field replaceable unit.

**FTP.** File Transfer Protocol.

## G

**gateway.** (1) A functional unit that interconnects two computer networks with different network architectures. A gateway connects networks or systems of different architectures. A bridge interconnects networks or systems with the same or similar architectures. (T) (2) In the IBM Token-Ring Network, a device and its associated software that connect a local area network to another local area network or a host that uses different logical link protocols.

**Gbps.** Gigabits per second (1 000 000 000 bits per second).

**GUI.** Graphical user interface.

## H

**HPDT.** High Performance Data Transfer

**HDLC.** High-level data link control.

**high-level data link control (HDLC).** An access service used over data networks. It uses a non-real-time connection.

HDLC-like data link control, for example:

- Synchronous data link control (SDLC) used with SNA, or
- Link access procedure for D-channel (LAP-D) used with ISDN.

**high-performance file system (HPFS).** In the OS/2 operating system, an installable file system that uses high-speed buffer storage, known as a cache, to provide fast access to large disk volumes. The file system also supports the coexistence of multiple, active file systems on a single personal computer, with the capability of multiple and different storage devices. File names used with the HPFS can have as many as 254 characters.

**high-performance routing (HPR).** An addition to the Advanced Peer-to-Peer Networking (APPN) architecture that enhances data routing performance and reliability, especially when using high-speed links.

**hot pluggable.** Refers to a hardware component that can be installed or removed without disturbing the operation of any other resource that is not connected to, or dependant on, this component.

**HPDT.** High-Performance Data Transfer.

**HPFS.** High-performance file system.

**HS.** High-speed.

**HSA.** High-speed adapter (module).

**HSDS.** High-Speed Digital Services.

**HSSI.** High-speed serial interface.

**hub (intelligent).** A wiring concentrator, such as the IBM 8260, that provides bridging and routing functions for LANs with different cables and protocols.

## I

**IDNX.** Integrated Digital Network Exchange.

**IEEE.** Institute of Electrical and Electronics Engineers.

**impedance.** The combined effect of resistance, inductance, and capacitance on a signal at a given frequency.

**integrated services digital network (ISDN).** A digital end-to-end telecommunication network that supports multiple services including, but not limited to, voice and data.

**Note:** ISDNs are used in public and private network architectures.

**interface.** (1) A shared boundary between two functional units, defined by functional characteristics, signal characteristics, or other characteristics, as appropriate. The concept includes the specification of the connection of two devices having different functions. (T) (2) Hardware, software, or both, that links systems, programs, or devices.

**Intermediate Session Routing (ISR).** A type of routing function within an APPN network node that provides session-level flow control and outage reporting for all sessions that pass through the node but whose end points are elsewhere.

**International Organization for Standardization (ISO).** An organization of national standards bodies from various countries established to promote development of standards to facilitate international exchange of goods and services, and develop cooperation in intellectual, scientific, technological, and economic activity.

**internet.** A collection of networks interconnected by a set of routers that allow them to function as a single, large network. See also *Internet*.

**Internet.** A worldwide network connecting users through autonomous networks in industry, education, government, and research. The Internet network uses Internet Protocol (IP). The major Internet services include electronic mail, FTP, telnet, World Wide Web, and electronic bulletin boards (Usenet). For network

interconnection and routing, and Transmission Control Protocol (TCP) for end-to-end control. (A)

**Internet Protocol (IP).** A connectionless protocol that routes data through a network or interconnected networks. IP acts as an intermediary between the higher protocol layers and the physical network. However, this protocol does not provide error recovery and flow control and does not guarantee the reliability of the physical network.

**Internetwork Packet Exchange (IPX).** The network protocol used to connect Novell's servers, or any workstation or router that implements IPX, with other workstations. Although similar to the Internet Protocol (IP), IPX uses different packet formats and terminology.

**IP.** Internet Protocol.

**IPX.** Internetwork Packet Exchange.

**ISDN.** Integrated services digital network.

**ISM.** IBM Solution Manager.

**ISMD.** IBM Software Manufacturing and Delivery.

**ISO.** International Organization for Standardization.

**ISR.** Intermediate session routing.

**ITU-T.** International Telecommunication Union - Telecommunication (replaces CCITT).

## K

**Kbps.** Kilobits per second (1000 bits per second).

**kVA.** kilovolt amperes.

## L

**LAN.** Local area network.

**LAPD.** Link access procedure for D-channel.

**LCS.** Logical channel station.

**LED.** Light-emitting diode.

**LIC.** Line interface coupler.

**line switching.** Synonym for *circuit switching*.

**link.** The combination of the link connection (the transmission medium) and two link stations, one at each end of the link connection. A link connection can be shared among multiple links in a multipoint or token-ring configuration.

**Link Address.** For a 2216 with an ESCON Channel Adapter, a port number determined as follows: If one ESCD is in the communication path, it is the ESCON Director (ESCD) port number that is attached to the host. If two ESCDs are in the path, it is the host-side port number of the ESCD defined with the dynamic connection. When no ESCD is in the communication path, this value must be set to X'01.'

**link connection.** The physical equipment providing two-way communication between one link station and one or more other link stations; for example, a telecommunication line and data circuit-terminating equipment (DCE). Synonymous with *data circuit*.

**LMI.** Local management interface.

**local.** Pertaining to a device accessed directly without use of a telecommunication line.

**local area network (LAN).** (1) A computer network located on a user's premises within a limited geographical area. Communication within a local area network is not subject to external regulations; however, communication across the LAN boundary may be subject to some form of regulation. (T) (2) A network in which a set of devices are connected to one another for communication and that can be connected to a larger network. See also *Ethernet* and *token ring*. (3) Contrast with *metropolitan area network (MAN)* and *wide area network (WAN)*.

**logical partition (LP).** A subset of the processor hardware that is defined to support the operation of a system control program (SCP). See also *logically partitioned (LPAR) mode*.

**logically partitioned (LPAR) mode.** A central processor complex (CPC) power-on reset mode that enables use of the PR/SM feature and allows an operator to allocate CPC hardware resources (including central processors, central storage, expanded storage, and channel paths) among logical partitions. In LPAR mode, the ESCON adapter can share a physical fiber connection with multiple host partitions.

**LP.** Logical partition.

**LP number.** Logical partition number. This allows multiple logical host partitions (LPs) to share one ESCON fiber. This value is defined in the host Input/Output Configuration Program (IOCP) by the RESOURCE macro instruction. If the host is not using EMIF, use the default of 0 for the LP number.

**LPAR.** Logically partitioned.

**LPAR mode.** Logically partitioned mode.

**LS.** Low-speed.

**LSA.** Low-speed adapter (module).

## M

**MAN.** Metropolitan area network.

**Management Information Base (MIB).** (1) A collection of objects that can be accessed by means of a network management protocol. (2) A definition for management information that specifies the information available from a host or gateway and the operations allowed. (3) In OSI, the conceptual repository of management information within an open system.

**MB.** Megabyte (1 000 000 bytes).

**Mbps.** Megabits per second (1 000 000 bits per second).

**metropolitan area network (MAN).** A network formed by the interconnection of two or more networks which may operate at higher speed than those networks, may cross administrative boundaries, and may use multiple access methods. (T) Contrast with *local area network (LAN)* and *wide area network (WAN)*.

**MIB.** (1) MIB module. (2) Management Information Base.

**MLD.** Multicast Listener Discovery Protocol.

**modem (modulator/demodulator).** (1) A functional unit that modulates and demodulates signals. One of the functions of a modem is to enable digital data to be transmitted over analog transmission facilities. (T) (A) (2) A device that converts digital data from a computer to an analog signal that can be transmitted on a telecommunication line, and converts the analog signal received to data for the computer.

**MOSPF.** Multicast Extension to OSPF.

**MPC.** Multi-Path Channel.

**MPC+.** High-Performance Data Transfer (HPDT) Multi-Path Channel.

**ms.** Millisecond (1/1000 second).

## N

**NDP.** Neighbor discovery protocol.

**network.** (1) A configuration of data processing devices and software connected for information interchange. (2) A group of nodes and the links interconnecting them.

**network architecture.** The logical structure and operating principles of a computer network. (T)

**Note:** The operating principles of a network include those of services, functions, and protocols.

**network management.** The process of planning, organizing, and controlling a communication-oriented data processing or information system.

**NIC.** Network Information Center.

**NMS.** Network management station.

**NNI.** Network-to-network interface.

**non-return-to-zero change-on-ones recording (NRZ-1).** A recording method in which the ones are represented by a change in the condition of magnetization, and zeros are represented by the absence of change. Only the one signals are explicitly recorded. (Previously called *non-return-to-zero inverted*, NRZI, recording.)

**NRZ-1.** Non-return-to-zero change-on-ones recording.

**NSAP.** Network service address point.

**NSC.** Network Support Center.

**NVDM.** NetView Distribution Manager/6000.

## O

**OC.** Optical carrier.

**OSI.** Open systems interconnection.

## P

**packet loss ratio.** The probability that a packet will not reach its destination or not reach it within a specified time.

**packet mode operation.** Synonym for *packet switching*.

**packet switching.** (1) The process of routing and transferring data by means of addressed packets so that a channel is occupied only during transmission of a packet. On completion of the transmission, the channel is made available for transfer of other packets. (1)  
(2) Synonymous with *packet mode operation*. See also *circuit switching*.

**parallel channel.** A channel having a channel-to-control unit I/O interface that uses bus-and-tag cables as a transmission medium. Contrast with ESCON channel.

**PCA.** Parallel Channel Adapter.

**PBX.** Private branch exchange.

**PCM.** Pulse code modulation.

**PDH.** Plesiochronous digital hierarchy.

**permanent virtual circuit (PVC).** In X.25 and frame relay communications, a virtual circuit that has a logical channel permanently assigned to it at each data terminal equipment (DTE).

**PIM-DM.** Protocol-independent multicast-dense mode.

**physical circuit.** A circuit established without multiplexing. See also *data circuit*. Contrast with *virtual circuit*.

**PM.** Presentation Manager.

**PMF.** Parameter Management Frame.

**PNP.** Private numbering plan.

**Point-to-Point Protocol (PPP).** A protocol that provides a method for encapsulating and transmitting packets over serial point-to-point links.

**port.** (1) An access point for data entry or exit. (2) A connector on a device to which cables for other devices such as display stations and printers are attached. Synonymous with *socket*. (3) The representation of a physical connection to the link hardware. A port is sometimes referred to as an adapter; however, there can be more than one port on an adapter. There may be one or more ports controlled by a single DLC process. (4) In the Internet suite of protocols, a 16-bit number used to communicate between TCP or the User Datagram Protocol (UDP) and a higher-level protocol or application. Some protocols, such as File Transfer Protocol (FTP) and Simple Mail Transfer Protocol (SMTP), use the same well-known port number in all TCP/IP implementations. (5) An abstraction used by transport protocols to distinguish among multiple destinations within a host machine.

**PPP.** Point-to-Point Protocol.

**PR/SM.** Processor Resource/Systems Manager.

**private branch exchange (PBX).** A private telephone exchange for transmission of calls to and from the public telephone network.

**problem determination.** The process of determining the source of a problem; for example, a program component, machine failure, telecommunication facilities, user or contractor-installed programs or equipment, environmental failure such as a power loss, or user error.

### **Processor Resource/Systems Manager (PR/SM).**

The feature on a 3090 Processor Complex that offers flexible partitioning of a 3090 processing system into a number of logical partitions. Each partition within a PR/SM environment supports its own MVS or VSE image and VTAM, resulting in a multi-MVS or VSE environment.

**PRS.** Primary reference source.

**PSN.** Public switched network.

**PSTN.** Public switched telephone network.

**PTM.** Packet transfer mode.

**PVC.** Permanent virtual circuit.

## **Q**

**QoS.** Quality of service.

## **R**

**rack.** A metallic structure, with a standard 19-inch width, that houses Nways Switch hardware elements: logic subrack with modules, fan boxes, and power subrack with power units.

**real-time processing.** The manipulation of data that are required, or generated, by some process while the process is in operation. Usually the results are used to influence the process, and perhaps related processes, while it is occurring.

**RETAIN.** Remote Technical Assistance Information Network.

**ring.** See *ring network*.

**ring network.** (1) A network in which every node has exactly two branches connected to it and in which there are exactly two paths between any two nodes. (T)  
(2) A network configuration in which devices are connected by unidirectional transmission links to form a closed path.

**route.** (1) An ordered sequence of nodes and transmission groups (TGs) that represent a path from an origin node to a destination node traversed by the traffic exchanged between them. (2) The path that network traffic uses to get from source to destination.

**router.** (1) A computer that determines the path of network traffic flow. The path selection is made from several paths based on information obtained from specific protocols, algorithms that attempt to identify the shortest or best path, and other criteria such as metrics or protocol-specific destination addresses. (2) An

attaching device that connects two LAN segments, which use similar or different architectures, at the reference model network layer. Contrast with *bridge* and *gateway*. (3) In OSI terminology, a function that determines a path by which an entity can be reached.

**routing.** (1) The assignment of the path by which a message is to reach its destination. (2) In SNA, the forwarding of a message unit along a particular path through a network, as determined by parameters carried in the message unit, such as the destination network address in a transmission header.

**RSC.** Remote Support Center.

**RSF.** Remote Support Facility.

**RT.** Real time.

## **S**

**s.** Second.

**SDH.** Synchronous digital hierarchy.

**SDLC.** Synchronous Data Link Control.

**SDT.** Structured data transfer.

**Serial Line Internet Protocol (SLIP).** A TCP/IP protocol used on a point-to-point connection between two IP hosts over a serial line (for example, an RS/EIA-232 connection into a modem over a telephone line).

In an NBBS network, the SLIP is used over a connection between an Nways Switch administration station (NAS) and an IBM Network Support Center (NSC).

**Simple Network Management Protocol (SNMP).** In the Internet suite of protocols, a network management protocol that is used to monitor routers and attached networks. SNMP is an application layer protocol. Information on devices managed is defined and stored in the application's Management Information Base (MIB).

**SLA.** Serial link architecture.

**SLIP.** Serial Line Internet Protocol.

**SNA.** Systems Network Architecture.

**SNMP.** Simple Network Management Protocol.

**socket.** The abstraction provided by the University of California's Berkeley Software Distribution (commonly called Berkeley UNIX or BSD UNIX) that serves as an endpoint for communication between processes or applications.



**SONET.** Synchronous optical network.

**source route bridging.** In LANs, a bridging method that uses the routing information field in the IEEE 802.5 medium access control (MAC) header of a frame to determine which rings or token-ring segments the frame must transit. The routing information field is inserted into the MAC header by the source node. The information in the routing information field is derived from explorer packets generated by the source host.

**spoofing.** For data links, a technique in which a protocol initiated from an end station is acknowledged and processed by an intermediate node on behalf of the final destination. In IBM 6611 data link switching, for example, SNA frames are encapsulated into TCP/IP packets for transport across a non-SNA wide area network, unpacked by another IBM 6611, and passed to the final destination. A benefit of spoofing is the prevention of end-to-end session timeouts.

**SRC.** System reference code.

**STM-1.** Synchronous transport module-1.

**SW.** Switch (module).

**SWRD.** Switch redrive (module).

**synchronous.** (1) Pertaining to two or more processes that depend upon the occurrence of specific events such as common timing signals. (T)  
(2) Occurring with a regular or predictable time relationship.

**Synchronous Data Link Control (SDLC).** A discipline conforming to subsets of the Advanced Data Communication Control Procedures (ADCCP) of the American National Standards Institute (ANSI) and High-level Data Link Control (HDLC) of the International Organization for Standardization, for managing synchronous, code-transparent, serial-by-bit information transfer over a link connection. Transmission exchanges may be duplex or half-duplex over switched or nonswitched links. The configuration of the link connection may be point-to-point, multipoint, or loop. (I) Contrast with *binary synchronous communication (BSC)*.

**synchronous optical network (SONET).** A US standard for transmitting digital information over optical interfaces. It is closely related to the synchronous digital hierarchy (SDH) recommendation.

**system.** In data processing, a collection of people, machines, and methods organized to accomplish a set of specific functions. (I) (A)

**Systems Network Architecture (SNA).** The description of the logical structure, formats, protocols, and operational sequences for transmitting information

units through, and controlling the configuration and operation of, networks. The layered structure of SNA allows the ultimate origins and destinations of information, that is, the end users, to be independent of and unaffected by the specific SNA network services and facilities used for information exchange.

## T

**TCP.** Transmission Control Protocol.

**TCP/IP.** Transmission Control Protocol, Internet Protocol.

**TDM.** Time division multiplexing.

**Telnet.** In TCP/IP, an application protocol that allows a user at one site to access a remote system as if the user's display station were locally attached. Telnet uses the Transmission Control Protocol as the underlying protocol.

**TFTP.** Trivial File Transfer Protocol.

**time division multiplexing (TDM).** See *channelization*.

**TN3270.** An informally defined protocol for transmitting 3270 data streams over Telnet.

**token.** (1) In a local area network, the symbol of authority passed successively from one data station to another to indicate the station temporarily in control of the transmission medium. Each data station has an opportunity to acquire and use the token to control the medium. A token is a particular message or bit pattern that signifies permission to transmit. (T) (2) In LANs, a sequence of bits passed from one device to another along the transmission medium. When the token has data appended to it, it becomes a frame.

**token ring.** (1) According to IEEE 802.5, network technology that controls media access by passing a token (special packet or frame) between media-attached stations. (2) A FDDI or IEEE 802.5 network with a ring topology that passes tokens from one attaching ring station (node) to another. (3) See also *local area network (LAN)*.

**Transmission Control Protocol (TCP).** A communications protocol used in Internet and in any network that follows the U.S. Department of Defense standards for internetwork protocol. TCP provides a reliable host-to-host protocol between hosts in packet-switched communications networks and in interconnected systems of such networks. It assumes that the Internet protocol is the underlying protocol.

**Transmission Control Protocol/Internet Protocol (TCP/IP).** A set of communications protocols that

support peer-to-peer connectivity functions for both local and wide area networks.

**Transmission Control Protocol/Internet Protocol (TCP/IP).** A set of communication protocols that support peer-to-peer connectivity functions for both local and wide area networks.

**transparent bridging.** In LANs, a method for tying individual local area networks together through the medium access control (MAC) level. A transparent bridge stores the tables that contain MAC addresses so that frames seen by the bridge can be forwarded to another LAN if the tables indicate to do so.

**Trivial File Transfer Protocol (TFTP).** In the Internet suite of protocols, a protocol for file transfer that requires minimal overhead and minimal capability. TFTP uses the connectionless datagram delivery services of the User Datagram Protocol (UDP), which allows hosts that have no disk storage to implement TFTP in read-only memory (ROM) and use it to boot themselves.

## U

**UDP.** User Datagram Protocol.

**UNI.** User network interface (protocol).

**UTP.** Unshielded twisted pair.

## V

**V ac.** Volts alternating current.

**V.24.** In data communications, a specification of the CCITT that defines the list of definitions for interchange circuits between data terminal equipment (DTE) and data circuit-terminating equipment (DCE).

**V.25.** In data communications, a specification of the CCITT that defines the automatic answering equipment and parallel automatic calling equipment on the General Switched Telephone Network, including procedures for disabling of echo controlled devices for both manually and automatically established calls.

**V.35.** In data communications, a specification of the CCITT that defines the list of definitions for interchange circuits between data terminal equipment (DTE) and

data circuit-terminating equipment (DCE) at various data rates.

**V.36.** In data communications, a specification of the CCITT that defines the list of definitions for interchange circuits between data terminal equipment (DTE) and data circuit-terminating equipment (DCE) at rates of 48, 56, 64, or 72 kilobits per second.

**version.** A separately licensed program that usually has significant new code or new function.

**virtual circuit.** (1) In packet switching, the facilities provided by a network that give the appearance to the user of an actual connection. (T) See also *data circuit*. Contrast with *physical circuit*. (2) A logical connection established between two DTEs.

**virtual connection.** In frame relay, the return path of a potential connection.

**VPD.** Vital product data.

## W

**WAN.** Wide area network.

**wide area network (WAN).** (1) A network that provides communication services to a geographic area larger than that served by a local area network or a metropolitan area network, and that may use or provide public communication facilities. (T) (2) A data communications network designed to serve an area of hundreds or thousands of miles; for example, public and private packet-switching networks, and national telephone networks. Contrast with *local area network (LAN)* and *metropolitan area network (MAN)*.

## X

**X.21.** An International Telegraph and Telephone Consultative Committee (CCITT) recommendation for a general-purpose interface between data terminal equipment and data circuit-terminating equipment for synchronous operations on a public data network.

**X.25.** An International Telegraph and Telephone Consultative Committee (CCITT) recommendation for the interface between data terminal equipment and packet-switched data networks. See also *packet switching*.

---

# Index

## Numerics

- 2216
  - power-on 9-7
- 2216 base ix
- 2216 firmware
  - boot sequence 8-5
  - configuration management 8-3
  - function keys 8-2
  - help 8-2
  - mode of operation 8-1
  - testing a device 8-7
  - using 8-1
  - utilities, using 8-8

## A

- access methods, physical 7-1
- accessing the IBM 2216 9-1
- accessing the unit 7-1
- active file status D-2
- adapter
  - diagnostics 9-8
  - installation 4-10
  - moving, existing 4-10
  - power on 9-7
  - test 9-7
- adapter card status 1-3, 2-3
- adapter plugging E-1
- adapter wrap plugs 3-1
- adapter, inserting 5-16, 6-16
- adapter, model TX1 or TN1 6-15
- addresses, IP 8-19
- AIB test 9-14
- ASCII terminal setup attributes 7-4
- ASCII terminal, connection to the unit 7-3
- assumptions E-1
- attachment 4-3
- attachment rules 3-5
- attended mode 8-1
- attributes for ASCII terminal 7-4
- avail file status D-2

## B

- backplane, model TX1 or TN1 6-18
- bank for operational software images D-2
- boot config, TFTP file transfer in D-3
- boot configuration commands D-2
- boot sequence 8-5
- broken file status D-2

## C

- cable
  - duplex-to-biconic test 9-15
- cabling 4-10
  - attaching 4-10
  - connecting 4-10
  - disconnecting 4-14
  - optical fiber 4-14
- cabling to a channel 4-5
- change management D-1
  - copy command D-9
  - describe config images D-8
  - describe load images D-8
  - disable dumping D-8
  - enable dumping D-8
  - erase files D-9
  - managing software files D-1
  - other functions D-8
- change management function D-1
- change management functions D-8
- change supervisory password 8-13
- channel adapter 4-13
  - cable installation 4-14
  - connecting and disconnecting 4-10
  - installing 4-10
  - removing 4-13
- channel attachment 4-3
- channel cables 4-10
  - connecting and disconnecting cables 4-10
- channel cabling 4-10
- code updates D-5
- command line interface 9-7
- common tasks F-1
- config as seen in change management D-2
- configuration D-1
  - example of sending from the Configuration Program D-7
  - managing D-1
  - managing using the Configuration Program D-6
  - status D-2
  - viewing D-2
- configuration management 8-3
- configuration program D-6
  - using to manage the configuration files D-6
- configuring IP Addresses for PCMCIA LAN adapter F-11
- connecting power cord 4-2
- control panel functions, Model 400 1-1
- copy command in change management D-9
- corrections, documentation xiii

coupler, duplex-to-duplex 9-15

## D

dead man timer, manipulating 8-20  
describe config images D-8  
describe load images D-8  
Device List Page panel 9-2  
Device Status and Control Menu panel 9-3, 9-9, 9-11  
device test 8-7  
diagnostics  
  adapter 9-8  
  Diagnostic Menu panel 9-8  
  interactive test options 9-13  
  optical power measurement test 9-14  
  setup for optical test 9-15  
  Test Options panel 9-13, 9-14  
diagnostics, operational 9-1  
dimm 5-3  
disable dumping D-8  
disconnecting cables 4-14  
display  
  service terminal display unreadable 1-11  
documentation storage 4-18  
downloading files to the IBM 2216 D-1  
dual inline memory modules 5-3  
dumping, disabling D-8  
dumping, enabling D-8  
duplex-to-biconic test cable 9-15  
duplex-to-duplex coupler 9-15

## E

enable dumping D-8  
equipment, for FRU removal and replacement 4-1  
error log, displaying 8-16  
ESCON 4-14  
  optical fiber cables 4-14  
ESCON diagnostic tests 9-10  
ESD tool guidelines 4-9  
ESD tools, guidelines 4-9  
Etherjet PC card 7-1  
existing LAN adapter, moving 4-10  
External Wrap, LICs 282, 290, 291 3-3

## F

factory plugging defaults E-1  
fan, model TX1 or TN1 6-13  
file statuses D-2  
file transfer D-9  
file transfer using TFTP D-3  
file transfer using Xmodem D-5  
files D-2  
  active D-2  
  avail D-2

files (*continued*)

  broken D-2  
  corrupt D-2  
  local D-2  
  pending D-2  
filler panel 4-10  
firmware 8-1  
  help 8-2  
fixes xiii  
FRU exchange, model TX1 or TN1 6-1  
function keys 7-5, 8-2  
functions D-1, D-3  
  file transfer D-9  
  file transfer using TFTP D-3  
  file transfer using Xmodem D-5

## G

guidelines for using ESD tools 4-9

## H

hard drive, model TX1 or TN1 6-7  
help xiii  
help panels 8-2  
http sites xiii

## I

image of the operational software D-2  
insert adapter 5-16, 6-16  
installation  
  channel adapters 4-10  
  optical fiber cables 4-14  
  Parallel Channel Adapter 4-10  
  V-cables 4-7  
interactive test options 9-13  
interconnected v-cables 4-6, 4-8  
interface wrap plugs 3-1  
IP addresses 8-19  
IP addresses, configuring for PCMCIA LAN  
  adapter F-11  
IPL, setting up remote 8-19

## L

light reception test 9-10, 9-14  
list of parts B-1  
local access to 2216 7-3  
local file status D-2

## M

managing software files D-1  
managing the configuration 8-3  
MAPs (maintenance analysis procedures)  
  Parallel Channel problem isolation 1-14

MAPs (maintenance analysis procedures) *(continued)*

- verification MAP 1-15
- verifying the repair action 1-15
- memory DIMMs
  - inserting 5-16, 6-16
  - installing 5-11, 6-11
  - replacing 5-9, 6-9
- memory, Model 400 5-9, 5-11
- memory, Model TX1 or TN1 6-11
- memory, Network Utility 6-9
- messages
  - TTY console 9-7
- methods of access 7-1
- microcode D-1
- migrating to a new code level D-5
- miscellaneous equipment specification 4-9
- model 400 cable feature codes B-7
- Model 400 FRU exchange 5-1
- model TX1 or TN1 cable feature codes B-8
- model TX1 or TN1 FRU exchange 6-1
- modem feature codes B-6
- moving an existing adapter 4-10

## O

- OPCON
  - command line interface 9-7
  - description 9-7
- operating code D-5
- operational diagnostics 9-1
  - command line interface 9-2
- operator control module (OPCON) 9-7
- optical 4-14
  - installing 4-14
- optical power
  - meter 9-15
  - Setup for Optical Test panel 9-15
  - test 9-14
- Optical Test in Progress panel 9-16
- ordering publications xii

## P

- panels
  - Device List Page 9-2
  - Device Status and Control Menu 9-3, 9-9, 9-11
  - Diagnostic Menu 9-8
  - Optical Test in Progress 9-16
  - Restore from Light Reception Test 9-11
  - Restore from Light Reception Test panel 9-11
  - Restore From Wrap Test 9-9
  - Setup for Light Reception Test 9-10
  - Setup for Optical Test 9-15
  - Setup for Wrap Test 9-8
  - Test Options 9-8, 9-10, 9-14
  - Test Results 9-9, 9-12

- Parallel Channel Adapter
  - preparing the channels for testing 3-5
  - problem isolation 1-14
  - requirements 4-7
  - testing with wrap blocks 3-14
  - V-cable installation 4-7
- parallel channel cables 4-5, 4-6
- parts catalog B-1
- password, supervisory 8-9, 8-10
  - removing 8-13
- PCMCIA LAN adapter 7-1
- PCMCIA LAN adapter, configuring IP addresses F-11
- PCMCIA modem feature codes listed by
  - geography B-6
- pending file status D-2
- physical access methods 7-1
- physical specifications
  - Model 400 C-1
  - Network Utility C-2
- plugging defaults E-1
- plugging sequences E-1
- power assembly, model TX1 or TN1 6-2
- Power Cord 4-2
- power cord, removal and replacement 4-2
- power meter, optical 9-15
- power on
  - 2216 9-7
  - adapter 9-7
- power supply status 1-3
- power supply, Network Utility 2-1
- power test, optical 9-14
- preparing for testing 3-5
- problem determination, Model 400 1-1
  - basic verification 1-5
- problem determination, model TX1 or TN1
  - basic verification 2-4
- problem determination, Network Utility 2-1
- procedures
  - channel interface cable replacement 4-16
- processor card 4-9
- protective cover, ESCON 4-14
- publications
  - ordering xii

## R

- rack-mounting removal procedure 5-19, 6-19
- reload D-2
- removing channel adapters 4-13
- removing the &model TX1 or TN1 from the rack 6-19
- removing the 2216 from the rack 5-19
- repair equipment 4-1
- repair procedures
  - reinstalling Channel Interface Cable 4-16
- replacement procedures
  - removing Channel Interface Cable 4-16

- requirements for Parallel Channel Adapter 4-7
- resetting the IBM 2216 D-2
- restart D-2
- Restore From Wrap Test panel 9-9
- routing adapter cables through the cable guides 4-17
- rules for channel attachment 3-5

## S

- safety notices IBM 2216 H-4
  - translated H-4
- select/bypass switch 4-3
- selecting a device to test 8-7
- selecting the boot sequence 8-5
- sending configuration files from the Configuration Program D-7
- service kit 3-1
- service terminal display unreadable 1-11
- setting the power-on password 8-9
- settings, ASCII terminal 7-4
- setup attributes, ASCII terminal 7-4
- Setup for Light Reception Test panel 9-10
- Setup for Optical Test panel 9-15
- Setup for Wrap Test panel 9-8
- slots and adapters E-1
- software D-1
  - managing D-1
  - status D-2
  - viewing D-2
- software and configuration change management D-1
- start mode
  - disabling 8-12
  - enabling 8-11
- starting firmware 8-2
- storage for documentation 4-18
- supervisory password 8-9, 8-10
  - removing 8-13
- supported adapters, verifying 4-9
- system card status 1-3, 2-2
- system card, model TX1 or TN1 6-5

## T

- tasks, common F-1
- terminal settings 7-4
- terminal, ASCII 7-4
- terminal, attachment to 2216 7-3
- terminator 3-1
- test
  - adapter 9-7
  - AIB 9-14
  - cable, duplex-to-biconic 9-15
  - Device Status and Control Menu panel 9-3, 9-9, 9-11
  - interactive options 9-13
  - light reception 9-14

- test (*continued*)
  - optical power 9-14
  - Restore from Light Reception Test panel 9-11
  - Restore From Wrap Test panel 9-9
  - Test Options panel 9-8, 9-10, 9-13, 9-14
  - Test Results panel 9-9, 9-12
  - wrap plug 9-14
- test and terminator plugs 3-1
- Test Options panel 9-8, 9-10
- Test Results panel 9-9, 9-12
- testing a device 8-7
- testing a Parallel Channel Adapter 3-5
- TFTP for file transfer D-3
- tools, FRU removal and replacement 4-1
- translated safety notices H-1
- TTY console messages 9-7
- tying optical fiber cables 4-14

## U

- Unattended mode 8-1
- Unattended start mode
  - disabling 8-12
  - enabling 8-11
- updates xiii
- updating software to new level D-5
- updating system firmware 8-14
- using the utilities 8-8
- using tools ESD tools 4-9
- utilities, using 8-8

## V

- V-cables 4-7
  - installing 4-7
  - interconnected 4-8
  - replacement procedure 4-16
  - using interconnected 4-8
- vital product data 8-17

## W

- web sites xiii
- wrap block preparation 3-6
- wrap plug test 9-14
- wrap plugs 3-1

## X

- Xmodem for file transfer D-5
- Xmodem software selection 8-20

---

# Tell Us What You Think!

**2216 Nways Multiaccess Connector and  
Network Utility  
Service and Maintenance Manual  
Publication No. SY27-0350-05**

We hope you find this publication useful, readable, and technically accurate, but only you can tell us! Your comments and suggestions will help us improve our technical publications. Please take a few minutes to let us know what you think by completing this form. If you are in the USA, you can mail this form postage free or fax it to us at 1-800-253-3520. Elsewhere, your local IBM branch office or representative will forward your comments or you may mail them directly to us.

|                                                                          |                          |                          |
|--------------------------------------------------------------------------|--------------------------|--------------------------|
| <b>Overall, how satisfied are you with the information in this book?</b> | Satisfied                | Dissatisfied             |
|                                                                          | <input type="checkbox"/> | <input type="checkbox"/> |

|                                                                    |                          |                          |
|--------------------------------------------------------------------|--------------------------|--------------------------|
| <b>How satisfied are you that the information in this book is:</b> | Satisfied                | Dissatisfied             |
| Accurate                                                           | <input type="checkbox"/> | <input type="checkbox"/> |
| Complete                                                           | <input type="checkbox"/> | <input type="checkbox"/> |
| Easy to find                                                       | <input type="checkbox"/> | <input type="checkbox"/> |
| Easy to understand                                                 | <input type="checkbox"/> | <input type="checkbox"/> |
| Well organized                                                     | <input type="checkbox"/> | <input type="checkbox"/> |
| Applicable to your task                                            | <input type="checkbox"/> | <input type="checkbox"/> |

Specific comments or problems:

---

---

---

Please tell us how we can improve this book:

---

---

---

Thank you for your comments. If you would like a reply, provide the necessary information below.

\_\_\_\_\_  
Name

\_\_\_\_\_  
Address

\_\_\_\_\_  
Company or Organization

\_\_\_\_\_

\_\_\_\_\_  
Phone No.

\_\_\_\_\_



Fold and Tape

Please do not staple

Fold and Tape



NO POSTAGE  
NECESSARY  
IF MAILED IN THE  
UNITED STATES

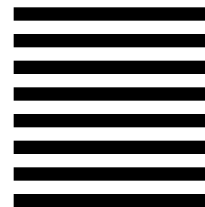

# BUSINESS REPLY MAIL

FIRST-CLASS MAIL PERMIT NO. 40 ARMONK, NEW YORK

POSTAGE WILL BE PAID BY ADDRESSEE

Design & Information Development  
Dept. CGF/Bldg. 656  
International Business Machines Corporation  
PO BOX 12195  
RESEARCH TRIANGLE PARK NC 27709-9990



Fold and Tape

Please do not staple

Fold and Tape







Part Number: 31L3208



Printed in the United States of America  
on recycled paper containing 10%  
recovered post-consumer fiber.

SY27-0350-05



31L3208



*Spine information:*



**2216 Nways Multiaccess Connector and  
Network Utility**

**Service and Maintenance Manual**